



# USER GUIDE

## VANGUARD L 340 - 7000

When replacing any part on this appliance, use only spare parts that you can be assured conform to the safety and performance specification that we require. Do not use reconditioned or copy parts that have not been clearly authorised by Ideal.

For the very latest copy of literature for specification and maintenance practices visit our website [www.idealcommercialboilers.com](http://www.idealcommercialboilers.com) where you can download the relevant information in PDF format.

# VANGUARD L

(Gas and Fuel Oil)

Destination Countries: GB, IE

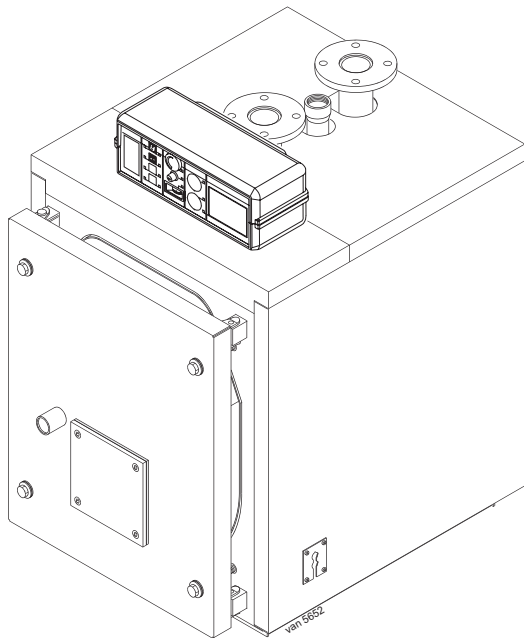

## INTRODUCTION

The Vanguard L is a floor-standing boiler featuring full sequence automatic gas or fuel oil burner.

## SAFETY

It is essential that the instructions in this booklet are strictly followed, for safe and economical operation of the boiler.

## FOR GAS FIRED BOILERS

### ***Current Gas Safety (Installation & Use) Regulations or rules in force.***

In your own interest, and that of safety, it is the law that this boiler must be installed and maintained by a Gas Safe Registered Engineer, in accordance with the above regulations. The appliance should be serviced at least once a year by a Gas Safe Registered Engineer.

## ELECTRICITY SUPPLY

The appliance must be earthed.

Control Panel: -  
Supply 230 V - 50 Hz. Fused at 4 amp.

The appliance control circuit is intended to be connected to the supply via a double-pole switch, having a 3mm contact separation in both poles, serving only the boiler and system controls. Alternatively, a 3-pin UNSWITCHED socket may be used.

Burner and pump:-  
These may be 1ph or 3ph. Refer to manufacturer's instructions.

All Gas Safe Registered Installers carry a Gas Safe Register ID card, and have a registration number. Both should be recorded in your Log Book. You can check your installer by calling Gas Safe Register direct on 0800 4085500

**CAUTION. To avoid the possibility of injury during the installation, servicing or cleaning of this appliance care should be taken when handling edges of sheet steel components**

## IMPORTANT NOTES

- Do not store objects around or on the boiler, and keep access clear at all times.
- Do not obstruct ventilation ducts, grilles or openings in the boiler room or the passage of combustion and ventilation air to the boiler.
- Do not turn off the boiler if it is to be left unattended in frosty weather.
- If it is known or suspected that a fault exists on the boiler then it **MUST NOT BE USED** until the fault has been corrected by a recognised installer (Gas Safe Registered for gas-fired boilers).
- Flammable materials must not be placed in close proximity to the appliance. Materials giving off flammable vapours must not be stored in the same room as the appliance.

In cases of repeated or continuous shutdown, a recognised installer (Gas Safe Registered for gas-fired boilers) should be called to investigate and rectify the condition causing this and carry out an operational test after each intervention on the device. Only the manufacturer's original parts should be used for replacement.

## MINIMUM CLEARANCES

Clearances of 500mm at the rear, 200mm plus burner projection on burner door hinge side, 100mm on the other side, (models 1100 to 2650 also require access to sludge hole on LH side), and the length of the boiler or 1200mm whichever is the smaller at the front of the boiler casing must be allowed for servicing.

## TO LIGHT THE BOILER (Refer to Frame 1)

1. CHECK THAT THE ELECTRICITY SUPPLY TO THE BOILER IS OFF.
2. Set the boiler on/off switch (11) to OFF.
3. Set the boiler flow control (21) to maximum.
4. Switch on the electricity supply to the boiler and check that all external controls, e.g. programmer, room thermostat etc., are on.
5. Set the burner (12) and pump (13) switches to ON.
6. Set the main boiler on/off switch (11) to ON.

The boiler will commence the ignition sequence, supplying heat to the system when required.

Note. If the burner does not ignite refer to the burner instructions.

7. Set the boiler temperature control (21) to the desired setting. (min. 50°C, max. 90°C).
8. **Burner**  
Refer to the instructions supplied with the burner for specific control features.

## 1 BOILER CONTROLS / DISPLAY

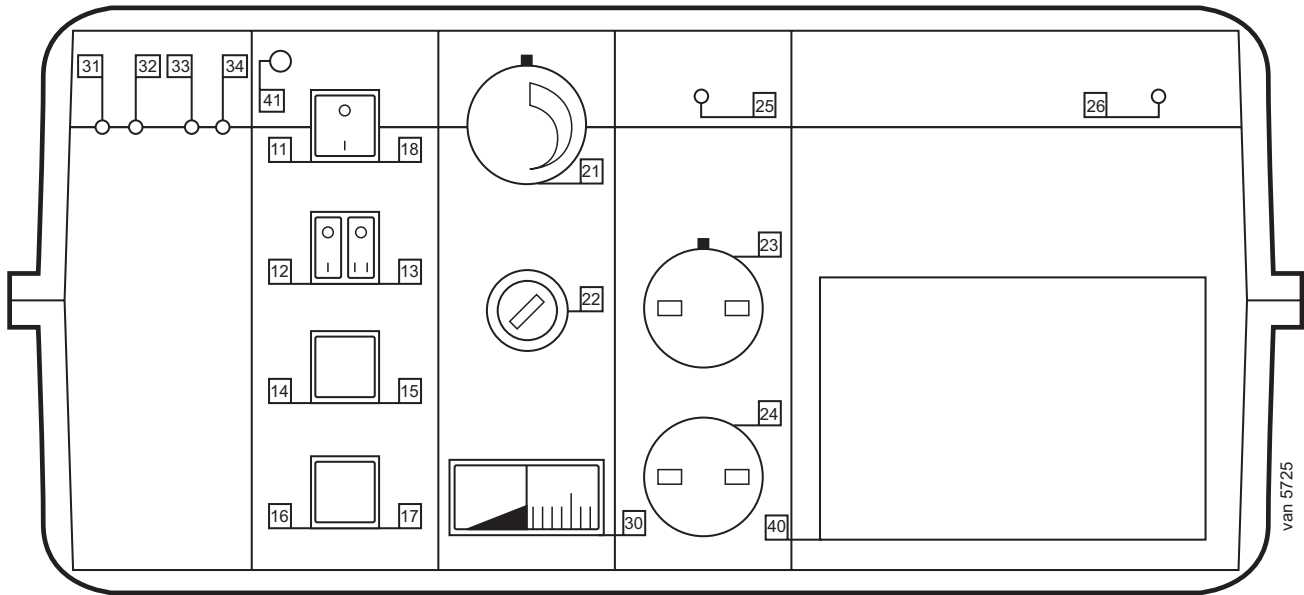

### 11. Boiler ON/OFF Switch (illuminated)

Position **I** . . ON. Position **O** . . OFF.

### 12. Burner Switch

Position **I** . . ON. Position **O** . . OFF.

### 13. Pump Switch

Position **||** . . ON. Position **O** . . OFF.

### 21. Boiler ON/OFF, High/Low Thermostat

50°C-90°C for ON/OFF operation

(High fire 54°C - 84°C, low fire 60°C - 90°C)for High/ Low Operation

### 22. Boiler Safety Thermostat

(Set at 100°C) with manual reset.

### 24. Minimum Thermostat

(Set at 50°C) Controls the pump operation.

### 30. Thermometer

Indicator flow temperature.

## 2 CONTROL OF WATER TEMPERATURES

The water temperature is controlled by the boiler thermostat (item 21). The temperature range of the thermostat is 50° - 90°C for ON/OFF operation. For boilers fitted with high/low burners the thermostat also incorporates a feature which automatically controls the burner changeover from high fire to low fire at a fixed 6° below the flow temperature setting (i.e. 44°C to 84°C).

## TO SHUT DOWN THE BOILER

### 1. For short periods

Set the boiler on/off switch (11) to OFF.

### 2. For longer periods

Set the boiler on/off switch (11) to OFF. Switch the electricity supply to OFF. For longer periods the entire system should be drained.

## TO RELIGHT THE BOILER

Refill the system if it has been drained, taking care to ensure no air is in the boiler or system.

Repeat the procedure detailed in 'To light the boiler'.

## FROST PROTECTION

If frost is likely and dependant on the system controls, which may incorporate suitable safety features, leave the boiler thermostat at a reduced temperature setting. Ensure external controls allow the boiler to operate if necessary. Note that this may not protect remote parts of the system, in which case a separate frost thermostat should be fitted or the system drained and the boiler shut down, as for Long Periods.

## BOILER OVERHEAT THERMOSTAT

Boiler overheating is detected by the overheat thermostat connected to the boiler control module. If the boiler overheats, it will shutdown the burner but the circulating pump will continue to run until the water cools below 40°C. Press the safety thermostat reset button, under the screw top cap (22), and the burner will relight. If the fault recurs, turn off the boiler and consult a recognised installer (Gas Safe Registered for gas-fired boilers.)

## ESCAPE OF GAS

Should a gas leak or fault be suspected contact your local gas supplier without delay.

**Do NOT search for gas leaks with a naked flame.**

## CLEANING

For normal cleaning simply dust with a dry cloth.

To remove stubborn marks and stains use a damp cloth and mild detergent

DO NOT use abrasive cleaning materials.



Ideal Boilers Ltd. pursues a policy of continuing improvement in the design and performance of its products. The right is therefore reserved to vary specification without notice.

Ideal is a trademark of Ideal Boilers.

Registered Office

Ideal Boilers Ltd., PO Box 103, National Avenue, Kingston Upon Hull, HU5 4JN

Tel 01482 492251 Fax 01482 448858

Registration No. London 322 137

Ideal Technical Helpline: 01482 498376

[www.idealcommercialboilers.com](http://www.idealcommercialboilers.com)