

# + USER GUIDE

## FALCON GTS 4 - 8

When replacing any part on this appliance, use only spare parts that you can be assured conform to the safety and performance specification that we require. Do not use reconditioned or copy parts that have not been clearly authorised by Ideal.

**For the very latest copy of literature for specification and maintenance practices visit our website [www.idealcommercialboilers.com](http://www.idealcommercialboilers.com) where you can download the relevant information in PDF format.**

# Falcon GTS (Gas and Fuel Oil)

PI No. 1312 BR 4657 Destination Countries: GB, IE

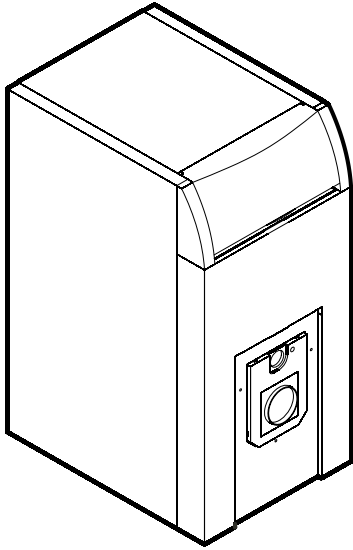

## INTRODUCTION

The **Falcon GTS** is a floor-standing boiler featuring full sequence automatic gas or fuel oil burner.

## SAFETY

*It is essential that the instructions in this booklet are strictly followed, for safe and economical operation of the boiler.*

## FOR GAS FIRED BOILERS

### **Current Gas Safety (Installation & Use) Regulations or rules in force.**

In your own interest, and that of safety, it is the law that this boiler must be installed and maintained by a Gas Safe Registered Engineer, in accordance with the above regulations.

The appliance should be serviced at least once a year by a Gas Safe Registered Engineer.

### **Electricity Supply**

The appliance must be earthed.

Supply 230 V - 50 Hz.

The appliance is intended to be connected to the supply via a double-pole switch, having a 3mm contact separation in both poles, serving only the boiler and system controls. Alternatively, a 3-pin UNSWITCHED socket may be used.

## Important Notes

- Do not store objects around or on the boiler, and keep access clear at all times.
- Do not obstruct ventilation ducts, grilles or openings in the boiler room or the passage of combustion and ventilation air to the boiler.
- Do not turn off the boiler if it is to be left unattended in frosty weather.
- If it is known or suspected that a fault exists on the boiler then it **MUST NOT BE USED** until the fault has been corrected by a recognised installer (Gas Safe Registered Engineer for gas-fired boilers).
- Flammable materials must not be placed in close proximity to the appliance. Materials giving off flammable vapours must not be stored in the same room as the appliance.

In cases of repeated or continuous shutdown, a recognised installer (Gas Safe Registered Engineer for gas-fired boilers) should be called to investigate and rectify the condition causing this and carry out an operational test after each intervention on the device. Only the manufacturer's original parts should be used for replacement.

## Minimum Clearances

Clearances of **500mm (20")** at the rear, **500mm (20")** at the sides and **1000mm (40")** at the front of the boiler casing must be allowed for servicing.

## To Light the Boiler (Refer to Frame 1)

1. CHECK THAT THE ELECTRICITY SUPPLY TO THE BOILER IS OFF.
2. Set the boiler on/off switch (1) to off.
3. Set the boiler flow control (7) and DHW temperature control (10) to maximum.
4. Switch on the electricity supply to the boiler and check that all external controls, e.g. programmer, room thermostat etc. are on and the Summer/Winter switch (3) is set to Winter.
5. Set the boiler on/off switch (1) to ON.

The boiler will commence the ignition sequence, supplying heat to the system when required.

**Note.** *If the burner does not ignite refer to the burner instructions.*

6. Set the boiler flow control (7) and DHW temperature control (10) (boilers fitted with optional DHW sensor), to the desired settings.

Settings below 4 (approx. 40°C) are not recommended, in order to avoid the risk of combustion products condensing on the walls of the boiler.

### 7. Burner

Refer to the instructions supplied with the burner for specific control features.

All Gas Safe Registered Engineers carry a Gas Safe Register ID card, and have a registration number. Both should be recorded in your Log Book. You can check your installer by calling Gas Safe Register direct on 0800 4085500

**CAUTION. To avoid the possibility of injury during the installation, servicing or cleaning of this appliance care should be taken when handling edges of sheet steel components**

# 1 BOILER CONTROLS / DISPLAY

## 1 Boiler on/off switch

Position  ..... ON    Position  .....OFF

## 2. Alarm light

Comes on when the burner is in safety lockout

## 3. Summer/Winter switch

**Winter**  Start the heating pump

**Summer**  The heating pump stops 12 minutes after the changeover to summer mode.

## 4. Test-STB button

When held in the pressed position it tests the safety thermostat and cuts off the pump(s)

## 5. Safety thermostat (with manual reset) Set to 110°C

## 6. Timed circuit breaker

(4A in control panel FM195, 6A in control panel FM196)

## 7. Electronic thermostat

Adjustment of the boiler flow temperature

## 8. Light on

Indicates the display above it is showing the boiler flow temperature

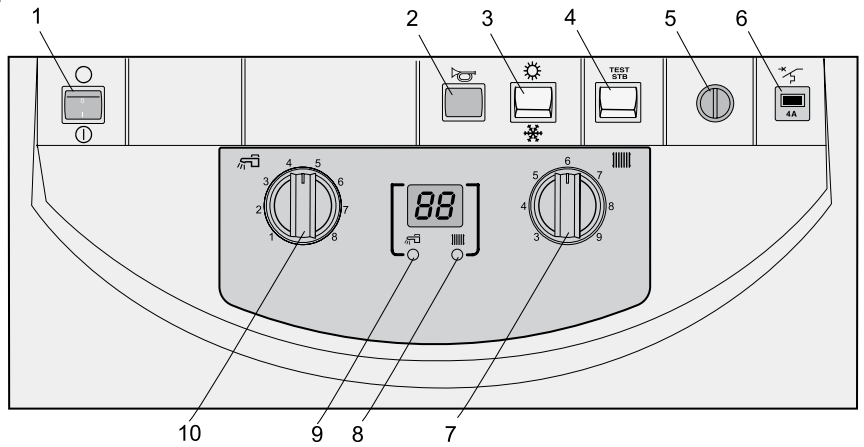

Bucc 6095

### DOMESTIC HOT WATER

(boilers fitted with a DHW sensor)

Items 9 & 10 only.

#### 9. Light on

Indicates the display above it is showing the DHW temperature.

#### 10. Electronic thermostat

Adjustment of the average DHW storage temperature

**Notes for items 9 & 10 only.**

*Boilers fitted with a DHW sensor. When the system is switched on it performs an air elimination sequence of the hot water calorifier lasting for 1 minute, by intermittently operating the DHW load pump and the CH pump. This air elimination sequence is de-activated if the calorifier temperature is more than 25°C*

**Summer/Winter Switch.** *If DHW has been in demand, a delay of approx. 1 minute will occur for the change from the DHW pump to the CH pump, after the changeover to Winter mode.*

# 2 CONTROL OF WATER TEMPERATURES

The water temperature may be controlled by the following control settings:

	Ctrl. Position	Approx. Temp.
1. Boiler flow temperature (CH)	3 to 9	30°C to 90°C
2. DHW (boilers fitted with DHW sensor)	1 to 8	10°C to 80°C

#### Note.

*In DHW mode the boiler flow temperature will automatically be controlled by the DHW temperature limiter.*

Settings below positions 4 (CH) and 6 (DHW) are NOT RECOMMENDED.

# 3 DISPLAY FEATURES

### Central Heating only

The green Heating LED illuminates and the display indicates boiler flow temperature.

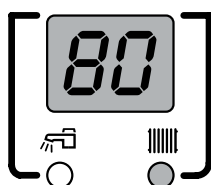

### Central Heating & DHW (boilers fitted with a DHW sensor)

Green LEDs for both boiler flow and DHW temperature illuminate alternately, as shown, and the display shows the appropriate boiler flow and DHW temperatures.

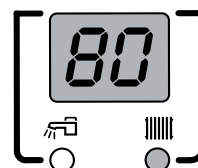

Boiler flow

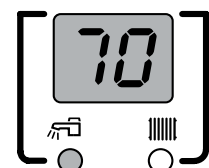

DHW temp

CONTINUED.....

## 4 DISPLAY FEATURES . . . . CONTINUED

### MESSAGES - ALARMS

The display may show the following messages in the case of a malfunction:

Message	Failure	Component	Probable Cause	Remedy	Notes
<b>AL50</b>	Installation stops	Boiler sensor	The corresponding sensor circuit is interrupted or is short circuited	Inform the installer	<i>If the power supply is interrupted with an <b>AL52</b> alarm and no corrective action is taken then, when the power is resumed, the boiler will restart but continue to operate in a CH mode only and alarm <b>AL50</b> will NOT be displayed.</i>
<b>AL52</b>	Installation continues to operate but DHW no longer heated	DHW sensor			
<b>AL62</b>	No DHW	AD212 kit connector	The calorifier is empty or incorrectly fitted AD212 kit connector	Fill the calorifier or check connector is properly fitted.	The DHW may be reactivated for 24 hours by disconnecting and reconnecting the power supply to the boiler.  Check that the connector supplied in the AD 212 kit (DHW Sensor), which has a 22kOhm resistance and a 100nF capacitor fitted, is correctly connected to terminals 25 and 26.
<b>AL6c</b>				Check that there is no short circuit or the connections are made correctly	

### To Shut Down the Boiler

#### 1. For short periods

Set the boiler on/off switch (1) to OFF.

#### 2. For longer periods

Set the boiler on/off switch (1) to OFF. Switch the electricity supply to OFF. For longer periods the entire system should be drained, including the domestic hot water supply.

### To Relight the Boiler

Refill the system if it has been drained, taking care to ensure no air is in the boiler or system.

Repeat the procedure detailed in 'To light the boiler'.

### Frost Protection

If frost is likely, leave the boiler thermostat at a reduced temperature setting. Ensure external controls allow the boiler to operate if necessary. Note that this may not protect remote parts of the system, in which case a separate frost thermostat should be fitted or the system drained and the boiler shut down, as for Long Periods.

### Boiler Overheat Thermostat

Boiler overheating is detected by the overheat thermostat connected to the boiler control module. If the boiler overheats, it will shut down the burner but the circulating pump will continue to run. The display may show **AL50** until the water cools. Press the safety thermostat reset button, under the screw top cap (5), and the burner will relight. If the fault recurs, turn off the boiler and consult a recognised installer (Gas Safe Registered for gas-fired boilers.)

### Escape of Gas

Should a gas leak or fault be suspected contact your local gas supplier without delay.

**Do NOT search for gas leaks with a naked flame.**

### Cleaning

For normal cleaning simply dust with a dry cloth.

To remove stubborn marks and stains use a damp cloth and mild detergent.

DO NOT use abrasive cleaning materials.