



# POD

## HEAT INTERFACE UNIT PRODUCT GUIDE



Ideal Heating was founded in 1906, meaning that we have over 100 years of providing the best quality heating solutions to our customers.

Operating from our manufacturing plant and design centre in Hull we have continually worked to meet ever-changing domestic heating needs.

With the advent of low carbon domestic heating in the UK, and in particular heat networks, we have applied our years of knowledge and experience to create the POD heat interface unit.



# CONTENTS

- 8 - Benefits of HIU
- 10 - POD By Ideal Heating
- 12 - We believe in quality & performance
- 13 - Metering & billing
- 14 - Pod Indirect
- 20 - Pod Direct
- 26 - Accessories
- 28 - Why Ideal Heating?
- 29 - Halo





# WE BELIEVE IN DECARBONISATION

## HEAT NETWORKS AND HEAT INTERFACE UNITS: A ROUTE TO DECARBONISATION

The need to reduce harmful greenhouse gas emissions is recognised across the world in order to limit global climate change. With the UK target to achieve Net Zero greenhouse gas emissions by 2050, both Government and consumers are focused on a greener future.

There will not be one single technology to enable the UK to achieve its Net Zero target and a diverse range of solutions to decarbonise heat must be considered. These solutions must not only deliver reduced carbon emissions but do so in a way that affords stakeholders the least disruption possible.



Heat networks, also known as district heating, are one of those solutions which can contribute to the reduction in carbon emissions resulting from heating buildings or dwellings and generating hot water. They are energy agnostic; there are many ways to generate the heat required by the network without relying solely on traditional fuel types.

An energy centre generates thermal energy in the form of hot water that is then distributed across a network. The network can be as large as a whole city or as small as a block of flats. This scalable solution for providing the heating and hot water needs of the consumer offers the opportunity for increased efficiency and reducing emissions by generating the thermal energy collectively.

Heat interface units (HIUs) are the part of the network that consumers interact with. They transfer the thermal energy from the network to the heating and hot water systems in buildings and dwellings.





## WE BELIEVE IN ENERGY EFFICIENCY

As a leading UK based manufacturer of domestic, commercial and industrial heating products, we are aware of the consequential impacts our operations and our products have on the environment.

This is not only in relation to the resources used within our manufacturing processes but also the energy used by our products once they are installed.

We recognise the importance of product design in this context and in terms of sustainable development. We continually strive to use renewable materials and energy resources in our design and production processes; to ensure that the products that we produce operate as efficiently as possible; and we are developing new products that will contribute to the decarbonisation of the UK.

Domestic heating and hot water production are one of the major areas contributing the carbon emissions from buildings in the UK, and the Clean Growth Strategy published in 2017 recognised that by 2050 heat networks could meet around 20% of the demand for heating and hot water in buildings.

As Ideal Heating are one of the largest manufacturers of products for that market we have an incredible opportunity to make a real difference to the way consumers heating and hot water are produced by providing them with a choice of the most efficient and low carbon technologies.

So alongside our range of domestic air source heat pumps Ideal Heating undertook the development of a new heat interface unit specifically for the UK.

# BENEFITS OF HIU

## FOR CONSULTANTS AND DEVELOPERS

Provide a means to meet standards and guidelines on carbon reduction for buildings through the integration of technologies that use renewable energy sources.

Improved energy efficiency resulting in better SAP/SBEM ratings compared with traditionally fuelled heating systems.

Consistent, efficient and predictable performance of a heat network through the selection and correct application of products certified using the BESA test regime.

Removal of individual gas connections and flues within dwellings or the building infrastructure.

## FOR NETWORK OPERATORS, LANDLORDS, HOMEOWNERS AND TENANTS

- Low maintenance appliances
- Increased levels of safety, no combustion within a dwelling
- No requirement for gas safety checks
- Compact space saving design
- Simple to own and operate
- Efficient heat network, reduced energy consumption, fair tariffs and reduced bills

Proportion of heat for buildings that could be provided through heat networks by 2050

# 20%





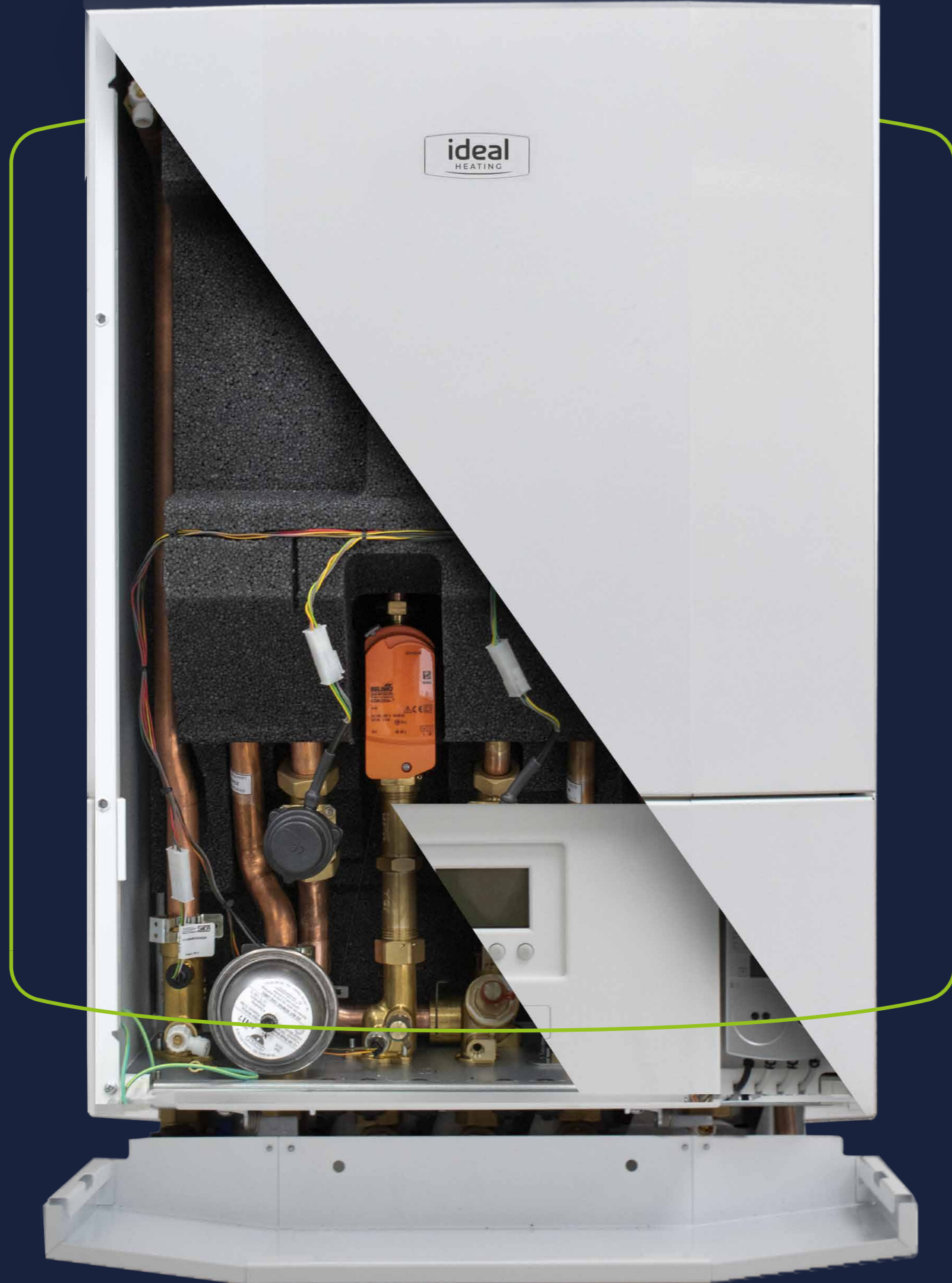

# POD

## BY IDEAL HEATING

### MADE WITH EVERYONE IN MIND

Created with our years of experience in developing domestic boilers, Pod combines the efficiency available from an HIU with the simplicity of use expected from a boiler. Available in Indirect and Direct models, there is a variant for every heat network.

Pod has been designed to look and work like a domestic boiler. It features a straightforward user interface and is easy to control via its OpenTherm compatibility. Also like a domestic boiler, it will fit in a kitchen cupboard.

We've also thought about the needs of contractors and installers. As well as being easy to install, a first fix kit is also available. This allows all services

to be piped up, flooded, flushed and tested in advance, ensuring the distribution network has all dirt and debris removed which will lead to optimum performance of the Pod and the heat network once they are completed. The first fix kit can be installed ahead of Pod, allowing flexible management of expenditure and time onsite.

Maintenance is also undemanding. Many of Pod's parts have already proved themselves on our domestic boiler range, such as the CH water set and O-ring push fit and clip retained connections, meaning maintenance should be trouble-free for those used to working on Ideal Heating boilers. To make that even easier, Pod is fully serviceable from the front.



# WE BELIEVE IN QUALITY & PERFORMANCE



## BRITISH MADE

We started designing and building our products from our site in Hull in 1906 and this continues to this day.

Pod has been created specifically for the UK heat network market. Our Research & Development team have developed an HIU that takes into account the requirements of domestic and commercial heating stakeholders in terms of performance, reliability and simplicity.

The products produced in our factory are made by people not robots and Pod is no different. Manufactured using processes perfected by building over 400,000 boilers a year, you can be assured that Pod is made to the highest possible quality.

By choosing Pod and Ideal Heating, you are supporting UK jobs and the UK economy.

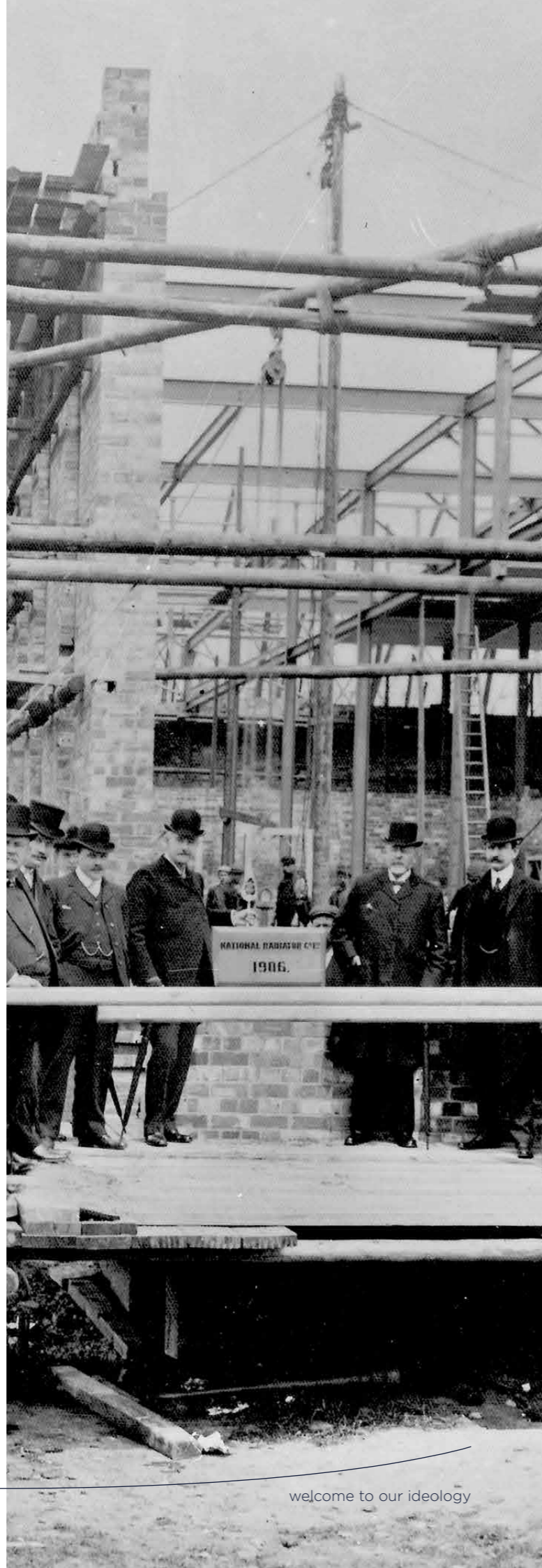

welcome to our ideology

# METERING & BILLING

A key part of using a heat network is metering and billing. It's vital that homeowners and tenants are fairly billed for the energy they use.

All Pod models are available as a complete unit with either Mbus hardwired or Mbus wireless heat meters. Alternatively, you can specify your Pod without a heat meter if you are already operating a fleet of HIUs and want to retain your current metering equipment.

As billing is an important part of selecting an HIU provider, we've teamed up with Sycous. Currently providing solutions to over 200 organisations here and in Europe and the Middle East, Sycous offer a range of billing packages, ranging from a managed service for part of your heat network to complete outsourced metering and billing.

Based in the UK, Sycous count a number of local authorities and housing associations as partners, including the London Boroughs of Camden and Haringey, Anchor Hannover and The Guinness Partnership.



[idealheating.com](http://idealheating.com)

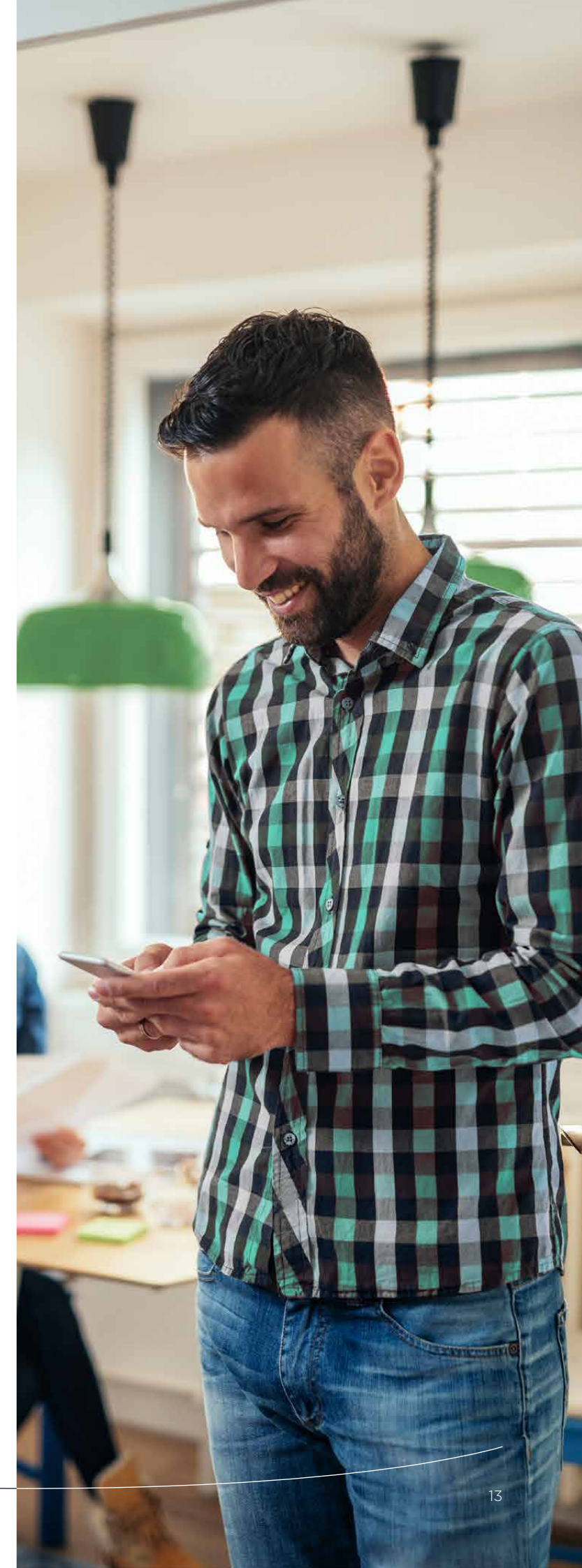



# POD INDIRECT

i305 i405 i505 i605 i705

Available in outputs of 30, 40, 50, 60 and 70kW, the indirect Pod HIU is designed to meet all the requirements of the heat network installer, operator and end user. Also available as direct appliances.



## FEATURES & SPECIFICATION

- 2 year warranty\*
- Robust steel chassis
- Internal insulation
- Copper pipework
- DZR Brass components
- Stainless steel brazed plate heat exchanger
- Advanced control features, simple to use interface
- Compact unit with minimal installation clearances
- Appliance fully serviceable from the front
- WRAS Approved Product
- BESA Tested / Published

## CLEARANCES & DIMENSIONS



All dimensions in mm

The following minimum clearances must be maintained for operation and servicing:

- ↑ TOP: 100mm, for front cover removal and ventilation
- ↔ SIDES: 20mm
- FRONT: 25mm min, 450mm recommended for servicing
- ↓ BOTTOM: 80mm

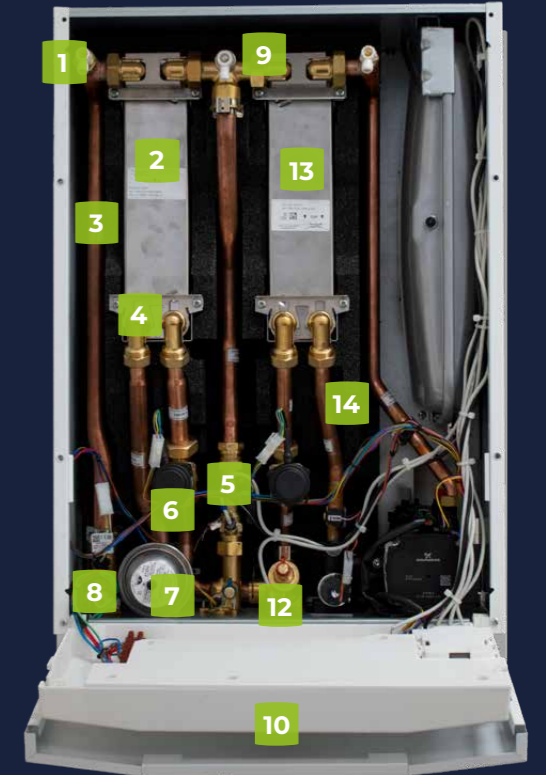

## HIU ASSEMBLY

### KEY

1. Steel chassis
2. DHW plate heat exchanger
3. Copper pipework
4. Quick release connections
5. Heat meter (optional)
6. DHW PICV
7. DHW water hammer arrestor
8. DHW flow limiter
9. Drain / vent points
10. First fix kit with temporary filling loop
11. Reversible service connections
12. Primary inlet strainer
13. CH PICV
14. Internal clamshell insulation
15. CH circulation pump
16. CH expansion vessel

\*2 year warranty subject to Terms and Conditions. 2 years parts and labour warranty available subject to being commissioned by Ideal Heating or an authorised representative. Terms & conditions available on request.



## PERFORMANCE DATA

### PRIMARY

MODEL		i305	i405	i505	i605	i705
Maximum Working Pressure	bar	16				
Maximum Temperature	°C	85				
Maximum Flow Rate DHW	l/h	1330				
	l/sec	0.37				
Maximum Flow Rate CH	l/h	1330				
	l/sec	0.37				
Minimum Pressure Differential	kPa	50				
Maximum Pressure Differential	kPa	600				
Nominal Temperatures DHW	°C	70 / 25				
Nominal Flow Rate DHW	l/sec	0.16	0.21	0.27	0.32	0.37
Nominal Temperatures CH	°C	70 / 40				
Nominal Flow Rate CH Radiator	l/sec	0.04				
Nominal Flow Rate CH Underfloor	l/sec	0.04				

### SECONDARY DHW

MODEL		i305	i405	i505	i605	i705
Nominal Heat Input	kW	30	40	50	60	70
Maximum Working Pressure	bar	10				
Maximum Temperature	°C	60				
Nominal Temperatures DHW	°C	10 / 55				
Nominal Flow Rate DHW	l/sec	0.16	0.21	0.27	0.32	0.37
	l/min	9.6	12.6	16.2	19.2	22.2

### SECONDARY CH

MODEL		i305	i405	i505	i605	i705
Nominal Heat Input	kW	5	5	5	5	5
Maximum Working Pressure	bar	2.5				
Maximum Temperature	°C	80				
Nominal Temperatures CH Radiator	°C	55 / 35				
Nominal Flow Rate CH Radiator	l/sec	0.06				
Nominal Temperatures CH Underfloor	°C	45 / 35				
Nominal Flow Rate CH Underfloor	l/sec	0.12				
Available Pump Head	kPA	35				

## GENERAL DATA

MODEL		i305	i405	i505	i605	i705
Service Pipework Connection Size	mm	22				
Pressure Relief Discharge Pipe Size	mm	15				
Electrical Supply		230v - 50Hz				
Fuse Rating	A	3				
Power Consumption	W	53.1				
Credit Control Input	V	230				
Modulating Input		OpenTherm				
Dry Weight	kg	29.0	29.4	29.8	30.3	30.6

OPTIONAL KITS	i305	i405	i505	i605	i705
Hardwired Mbus Heat Meter	✓	✓	✓	✓	✓
Wireless OMS Mbus Heat Meter	✓	✓	✓	✓	✓
Temporary Flushing Loop	✓	✓	✓	✓	✓
Permanent Flushing Bypass Valve	✓	✓	✓	✓	✓
Ideal System Filter (CH)	✓	✓	✓	✓	✓
Outside Thermostat Kit	✓	✓	✓	✓	✓
Programmable Room Thermostat Kit	✓	✓	✓	✓	✓
Credit Control Valve Kit	✓	✓	✓	✓	✓

## PERFORMANCE DATA

MODELS	INDIRECT					
	POD i305	POD i405	POD i505	POD i605	POD i705	
Primary Supply Temperature @ 50kPa	70°C					
Primary Flow Rate	l/s	0.188	0.265	0.314	0.310	0.319
Primary Return Temperature	°C	30.3	31.7	30.0	25.1	22.0
Primary Pressure Drop	kPa	52	51	48	51	54
DHW Flow Rate (60°C @ 50K rise)	l/min	9.3	11.9	15.4	19.4	24.5
DHW Output (60°C @ 50K rise)	kW	30.6	41.0	50.7	54.9	61.6
Primary Flow Rate	l/s	0.16	0.23	0.27	0.31	0.33
Primary Return Temperature	°C	24.3	27.1	25.9	18.6	23.0
Primary Pressure Drop	kPa	51	50	53	49	59
DHW Flow Rate (55°C @ 45K rise)	l/min	9.7	13.3	16.7	19.0	22.4
DHW Output (55°C @ 45K rise)	kW	30.7	39.9	50.6	57.9	63.4
Primary Flow Rate	l/s	0.16	0.21	0.26	0.29	0.32
Primary Return Temperature	°C	22.7	23.57	22.85	23.2	22.3
Primary Pressure Drop	kPa	53	51	51	54	55
DHW Flow Rate (50°C @ 40K rise)	l/min	11.6	14.9	18.4	21.3	25.5
DHW Output (50°C @ 45K rise)	kW	31.0	39.3	50.6	56.9	63.9
Primary Flow Rate	l/s	0.12	0.18	0.22	0.26	0.29
Primary Return Temperature	°C	18.2	20.3	19.2	20.4	20.8
Primary Pressure Drop	kPa	57	52	48	47	50
DHW Flow Rate (45°C @ 35K rise)	l/min	11.1	15.3	19.5	21.8	24.6
DHW Output (45°C @ 35K rise)	kW	26.4	35.3	46.9	51.1	58.4
CH Flow Rate (65°C - 35°C)	l/min	4.29				
CH Output (65°C - 35°C)	kW	6.4				
CH Flow Rate (70°C - 40°C)	l/min	4.07				
CH Output (70°C - 40°C)	kW	5.29				
<b>ELECTRICAL</b>						
Electrical Power Supply Voltage	AC Voltage	230				
Frequency	Hz	50				
Maximum Power Consumption	W	53.1				
Standby Power Consumption	W	2.8				
Appliance Protection Rating	IP	20				
Sound Power Level Indoors (LWA)	dB	48.6				

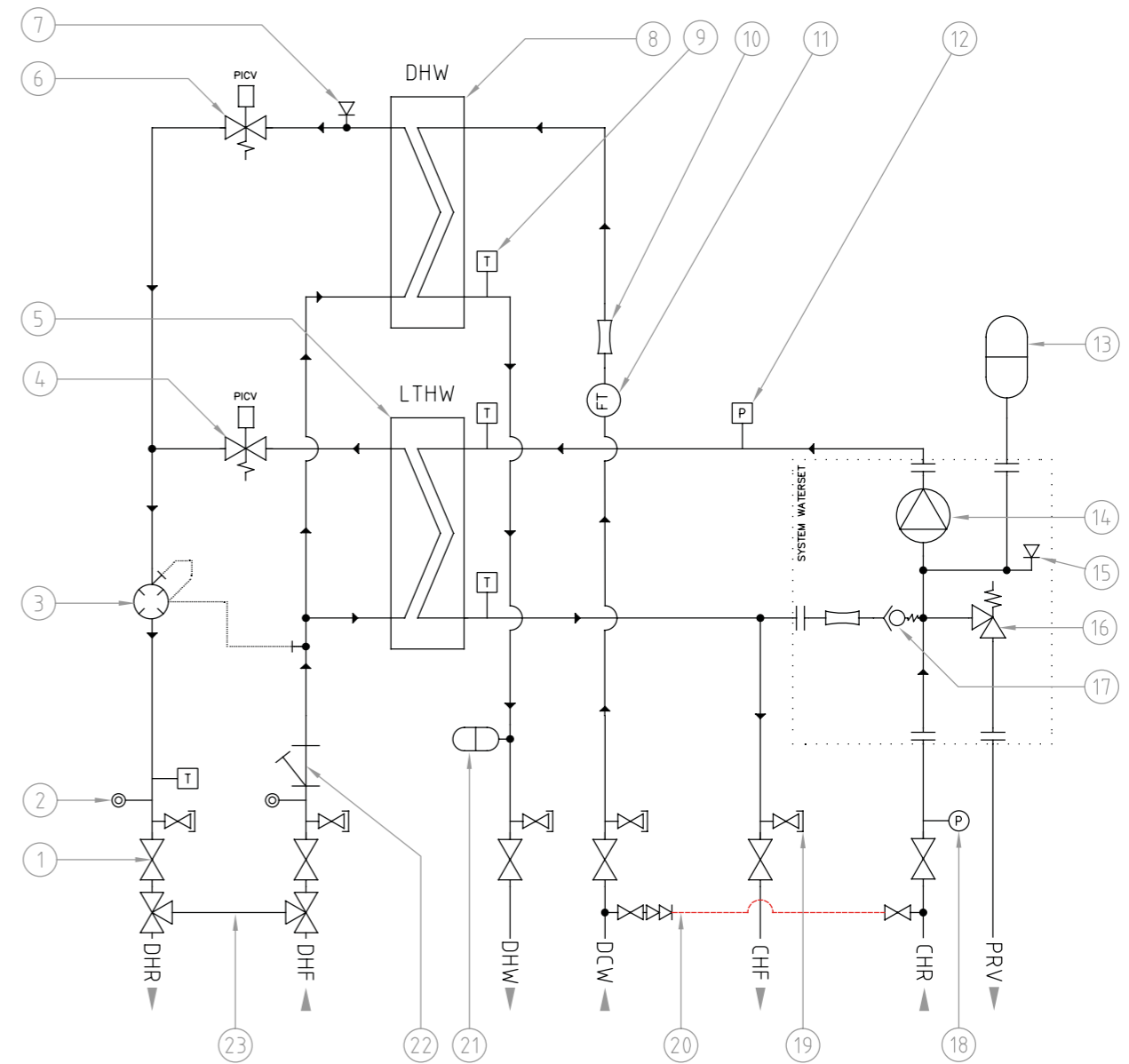

### KEY

- |                            |                             |                                 |
|----------------------------|-----------------------------|---------------------------------|
| 1 Service Valves           | 9 Temperature Sensors       | 17 CH Automatic Bypass          |
| 2 Pressure Test Points     | 10 DHW Flow Restrictor      | 18 CH Pressure Gauge            |
| 3 Heat Metering (Optional) | 11 DHW Flow Turbine         | 19 Combined Drain / Vent        |
| 4 CH PICV Control Valve    | 12 CH Pressure Sensor       | 20 Temporary Filling Loop       |
| 5 CH Plate Heat Exchanger  | 13 CH Expansion Vessel 8L   | 21 DHW Hammer Arrestor          |
| 6 DHW PICV Control Valve   | 14 CH Circulation Pump      | 22 Primary Strainer             |
| 7 Combined Drain / Vent    | 15 CH Auto-air Vent         | 23 Flushing Bypass Valve (Opt.) |
| 8 DHW Plate Heat Exchanger | 16 CH Pressure Relief Valve |                                 |



# POD DIRECT

D30 D40 D50 D60

Available in outputs of 30, 40, 50 & 60kW, the direct Pod HIU is designed to meet all the requirements of the heat network installer, operator and end user. Also available as indirect appliances.



## FEATURES & SPECIFICATION

- 2 year warranty\*
- Robust steel chassis
- Internal insulation
- Copper pipework
- DZR Brass components
- Stainless steel brazed plate heat exchanger
- Advanced control features, simple to use interface
- Compact unit with minimal installation clearances
- Appliance fully serviceable from the front
- WRAS Approved Product
- BESA Tested / Published\*\*

## CLEARANCES & DIMENSIONS

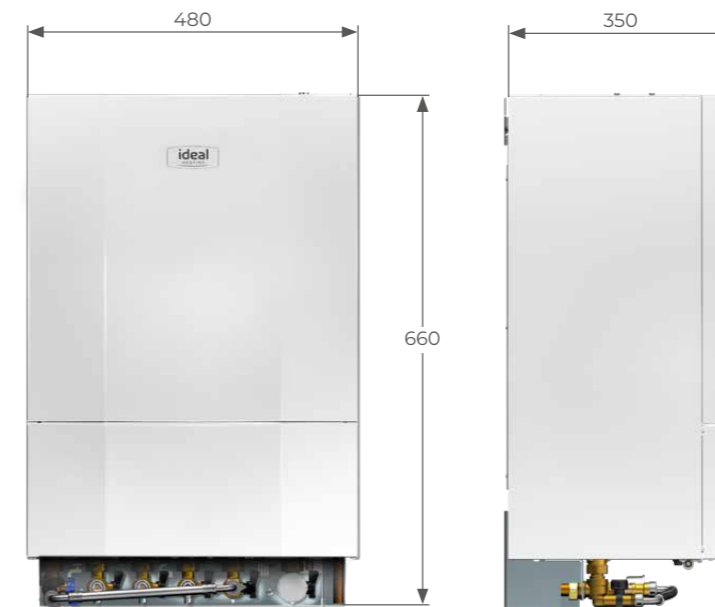

All dimensions in mm

The following minimum clearances must be maintained for operation and servicing:



\*2 year warranty subject to Terms and Conditions. 2 years parts and labour warranty available subject to being commissioned by Ideal Heating or an authorised representative. Terms & conditions available on request.

\*\* The BESA UK HIU Test Regime applies to indirect appliances only. For indirect DHW test results refer to published reports for the POD Indirect appliances.



## HIU ASSEMBLY

### KEY

1. Steel chassis
2. DHW plate heat exchanger
3. Copper pipework
4. Quick release connections
5. Heat meter (optional)
6. DHW PICV
7. DHW water hammer arrestor
8. DHW flow limiter
9. Reversible service connections
10. Primary inlet strainer
11. CH PICV
12. Internal clamshell insulation
13. Drain / vent points

## PERFORMANCE DATA

### PRIMARY

MODEL		D30	D40	D50	D60
Maximum Working Pressure	bar	16			
Maximum Temperature	°C	85			
Maximum Flow Rate DHW	l/h	1330			
	l/sec	0.37			
Maximum Flow Rate CH	l/h	1330			
	l/sec	0.37			
Minimum Pressure Differential	kPa	50			
Maximum Pressure Differential	kPa	600			
Nominal Temperatures DHW	°C	70 / 25			
Nominal Flow Rate DHW	l/sec	0.16	0.21	0.27	0.32
Nominal Temperatures CH	°C	70 / 40			
Nominal Flow Rate CH Radiator	l/sec	N / A			
Nominal Flow Rate CH Underfloor	l/sec	N / A			

### SECONDARY DHW

MODEL		D30	D40	D50	D60
Nominal Heat Input	kW	30	40	50	60
Maximum Working Pressure	bar	10			
Maximum Temperature	°C	60			
Nominal Temperatures DHW	°C	10 / 55			
Nominal Flow Rate DHW	l/sec	0.16	0.21	0.27	0.32
	l/min	9.6	12.6	16.2	19.2

### SECONDARY CH

MODEL		D30	D40	D50	D60
Nominal Heat Input	kW	N / A			
Maximum Working Pressure	bar	N / A			
Maximum Temperature	°C	N / A			
Nominal Temperatures CH Radiator	°C	N / A			
Nominal Flow Rate CH Radiator	l/sec	N / A			
Nominal Temperatures CH Underfloor	°C	N / A			
Nominal Flow Rate CH Underfloor	l/sec	N / A			
Available Pump Head	kPA	N / A			

## GENERAL DATA

MODEL		D30	D40	D50	D60
Service Pipework Connection Size	mm	22			
Pressure Relief Discharge Pipe Size	mm	15			
Electrical Supply		230V - 50Hz			
Fuse Rating	A	3			
Power Consumption	W	8.6			
Credit Control Input	V	230			
Modulating Input		OpenTherm			
Dry Weight	kg	22.9	23.3	23.7	24.2

OPTIONAL KITS	D30	D40	D50	D60
Hardwired Mbus Heat Meter	✓	✓	✓	✓
Wireless OMS Mbus Heat Meter	✓	✓	✓	✓
Temporary Flushing Loop	✓	✓	✓	✓
Permanent Flushing Bypass Valve	✓	✓	✓	✓
Ideal System Filter (CH)	✓	✓	✓	✓
Outside Thermostat Kit	✓	✓	✓	✓
Programmable Room Thermostat Kit	✓	✓	✓	✓
Credit Control Valve Kit	✓	✓	✓	✓



## PERFORMANCE DATA

MODELS	DIRECT				
	POD D30	POD D40	POD D50	POD D60	
Primary Supply Temperature @ 50kPa	70°C				
Primary Flow Rate	l/s	0.188	0.265	0.314	0.310
Primary Return Temperature	°C	30.3	31.7	30.0	25.1
Primary Pressure Drop	kPa	52	51	48	51
DHW Flow Rate (60°C @ 50K rise)	l/min	9.3	11.9	15.4	19.4
DHW Output (60°C @ 50K rise)	kW	30.6	41.0	50.7	54.9
Primary Flow Rate	l/s	0.16	0.23	0.27	0.31
Primary Return Temperature	°C	24.3	27.1	25.9	18.6
Primary Pressure Drop	kPa	51	50	53	49
DHW Flow Rate (55°C @ 45K rise)	l/min	9.7	13.3	16.7	19.0
DHW Output (55°C @ 45K rise)	kW	30.7	19.9	50.6	57.9
Primary Flow Rate	l/s	0.16	0.21	0.26	0.29
Primary Return Temperature	°C	22.7	23.57	22.85	23.2
Primary Pressure Drop	kPa	53	51	51	54
DHW Flow Rate (50°C @ 40K rise)	l/min	11.6	14.9	18.4	21.3
DHW Output (50°C @ 45K rise)	kW	31.0	39.3	50.6	56.9
Primary Flow Rate	l/s	0.12	0.18	0.22	0.26
Primary Return Temperature	°C	18.2	20.3	19.2	20.4
Primary Pressure Drop	kPa	57	52	48	47
DHW Flow Rate (45°C @ 35K rise)	l/min	11.1	15.3	19.5	21.8
DHW Output (45°C @ 35K rise)	kW	26.4	35.3	46.9	51.1
CH Flow Rate (65°C - 35°C)	l/min	N/A			
CH Output (65°C - 35°C)	kW	N/A			
CH Flow Rate (70°C - 40°C)	l/min	N/A			
CH Output (70°C - 40°C)	kW	N/A			
ELECTRICAL					
Electrical Power Supply Voltage	AC Voltage	230			
Frequency	Hz	50			
Maximum Power Consumption	W	8.6			
Standby Power Consumption	W	2.8			
Appliance Protection Rating	IP	20			
Sound Power Level Indoors (LWA)	dB	37.9			

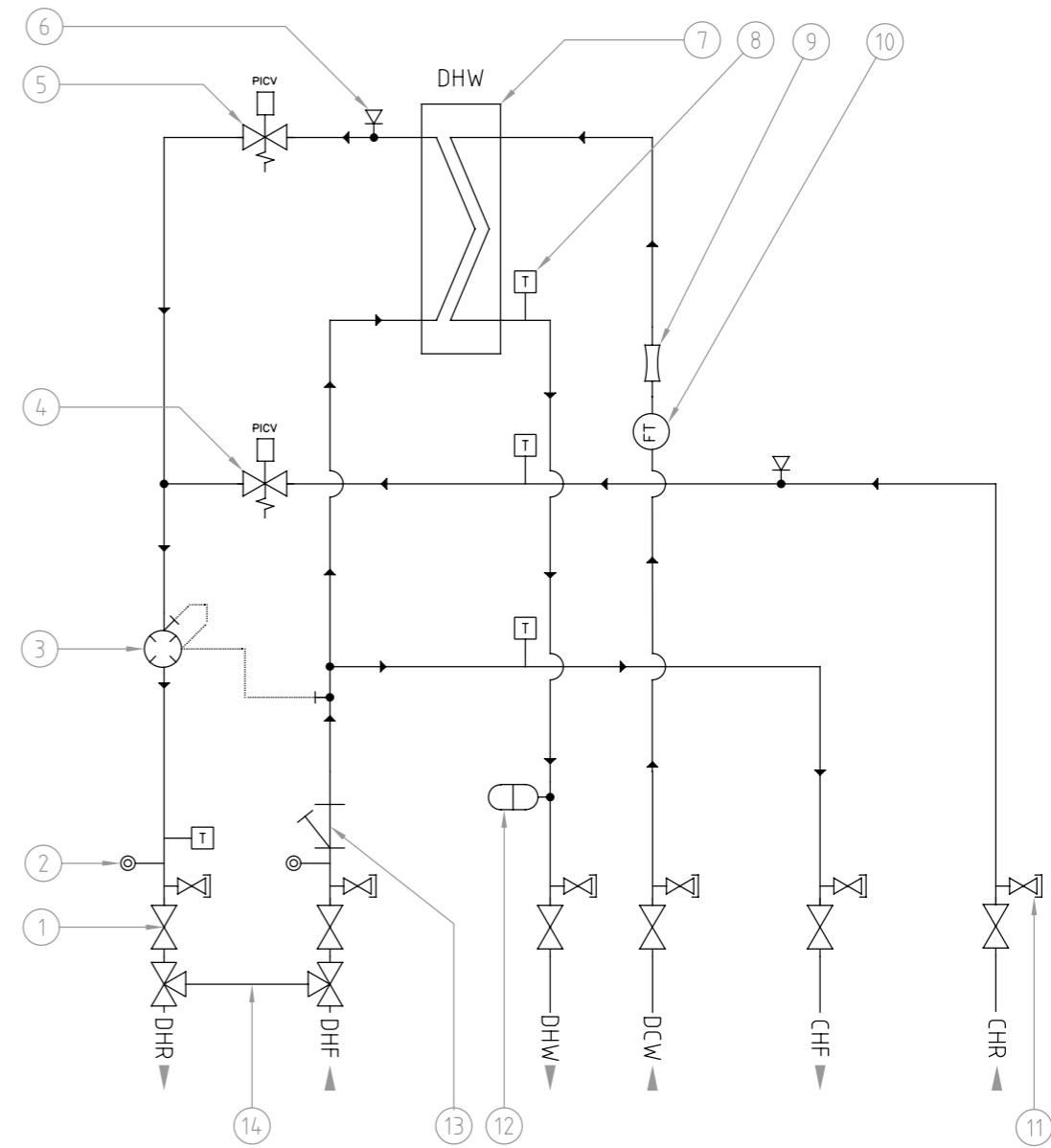

### KEY

- |                            |                                 |
|----------------------------|---------------------------------|
| 1 Service Valves           | 8 Temperature Sensors           |
| 2 Pressure Test Points     | 9 DHW Flow Restrictor           |
| 3 Heat Metering (Optional) | 10 DHW Flow Turbine             |
| 4 CH PICV Control Valve    | 11 Combined Drain / Vent        |
| 5 DHW PICV Control Valve   | 12 DHW Hammer Arrestor          |
| 6 Combined Drain / Vent    | 13 Primary Strainer             |
| 7 DHW Plate Heat Exchanger | 14 Flushing Bypass Valve (Opt.) |

# ACCESSORIES

## FIRST FIX KIT (OPTIONS FOR INDIRECT AND DIRECT)

Available separately from the HIU to allow for phased construction programs without the need to fit a HIU.

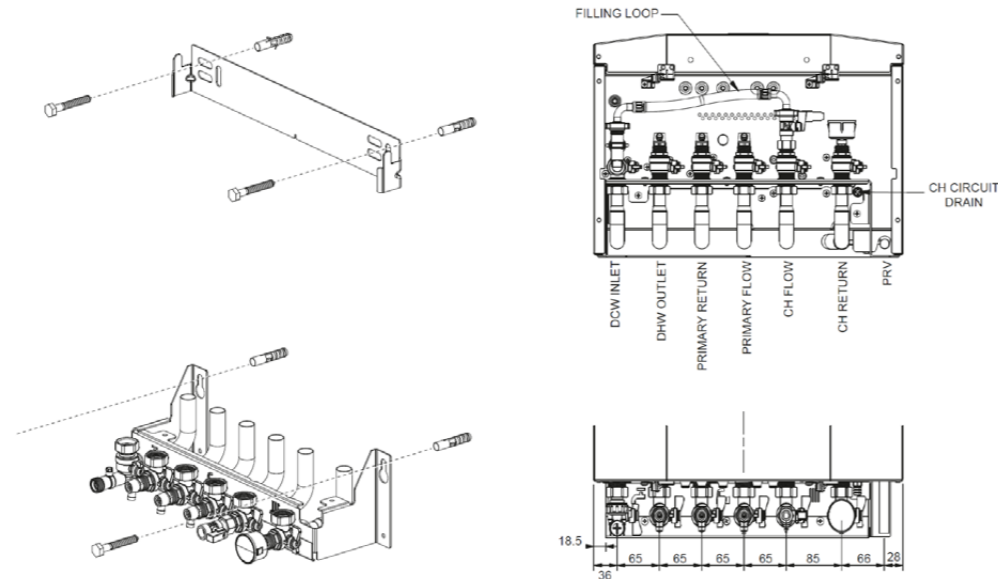

## PERMANENT FLUSHING BYPASS VALVE & UNION KITS

Facilitate flushing of the heat network where the HIU has already been installed, without exposing the HIU to the flushing process.



## TEMPORARY FLUSHING LOOP

Facilitate flushing of the heat network before the HIU is installed.

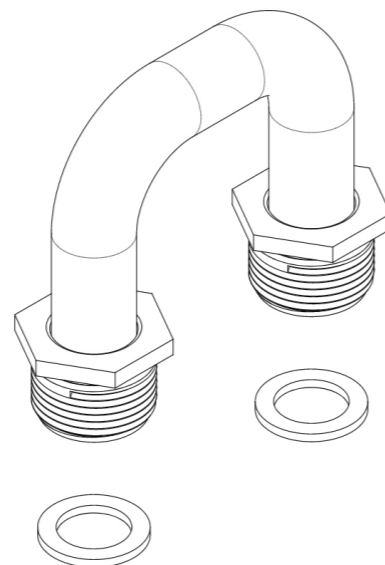

## HALO LITE

The Halo Lite smart thermostat gives you effortless control over your central heating thanks to fast, flexible and intelligent technology. (Halo Lite is a wired device. Halo WiFi and RF versions also available).



## IDEAL SYSTEM FILTER

The magnetic Ideal System Filter is designed to optimise HIU operation by removing impurities from the central heating water passing through it. Specifically designed to protect domestic central heating systems, this easy-to-use filter can help to maintain the efficiency of your HIU. Suitable for use with all Ideal HIU and features a compact design.



## HEAT METER

Providing both the end user and network operator with up to date information about individual energy usage for a dwelling. A compact, accurate, ultrasonic heat meter available in hard wired or wireless Mbus versions.





# WHY IDEAL HEATING?

## DESIGNED IN THE UK FOR THE UK

Ideal Heating is the UK's market leader of high efficiency commercial heating solutions.

Operating from its Hull manufacturing plant and offices since 1906, Ideal Heating is one of the few true British manufacturers left in the heating industry.

## FREE BOILER COMMISSIONING

Save up to £233 per boiler with our award winning Free Commissioning service available on all Evomax 2, Imax Xtra EL and Evomod condensing boiler ranges.

## SOMEONE YOU CAN TRUST

We are committed to delivering the highest level of customer service. With more than 100 years' of experience in the heating industry, we know how important confidence and trust are to our customers.

## ENERGY CENTRE OPTIONS

### CONDENSING BOILERS CAPABLE OF 30°ΔT



#### EVOMAX 2

- Wall Hung
- Aluminium Alloy Heat Exchanger
- 30 - 150kW
- 30 - 120kW LPG



#### IMAX XTRA EL

- Floor Standing
- Aluminium Alloy Heat Exchanger
- 320 - 1240kW



#### IMAX XTRA 2

- Floor Standing
- Aluminium Alloy Heat Exchanger
- 80 - 280kW



#### EVOMOD

- Floor Standing
- Stainless Steel Heat Exchanger
- Modular 250-1000kW



#### EVOJET

- Floor Standing
- Stainless Steel Heat Exchanger
- 150 - 1450kW
- Condensing Pressure Jet
- Natural Gas, LPG, Oil or Dual Fuel

# HALO

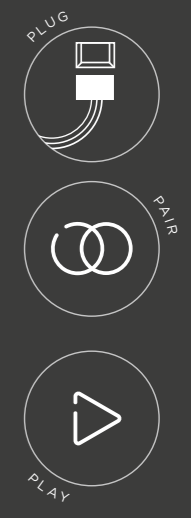

## INTELLIGENT CONTROL FOR ULTIMATE COMFORT

### IDEAL HALO COMBI WI-FI

The Ideal Halo Combi Wi-Fi is an internet connected wireless programmable room thermostat, designed to work specifically with Pod.

Halo Wi-Fi allows heating control anytime, anywhere through the flexible and intuitive Halo app. With features such as geolocation and compatibility with smart home assistants such as Amazon Alexa and Google Home, Halo provides smart, intelligent heating control.

For the installer, Halo Wi-Fi is simple to install without the need for a separate Wi-Fi gateway. Simply plug and pair the Smart Interface and Halo and then follow the step-by-step guidance in the Halo app to link Halo to the home Wi-Fi.

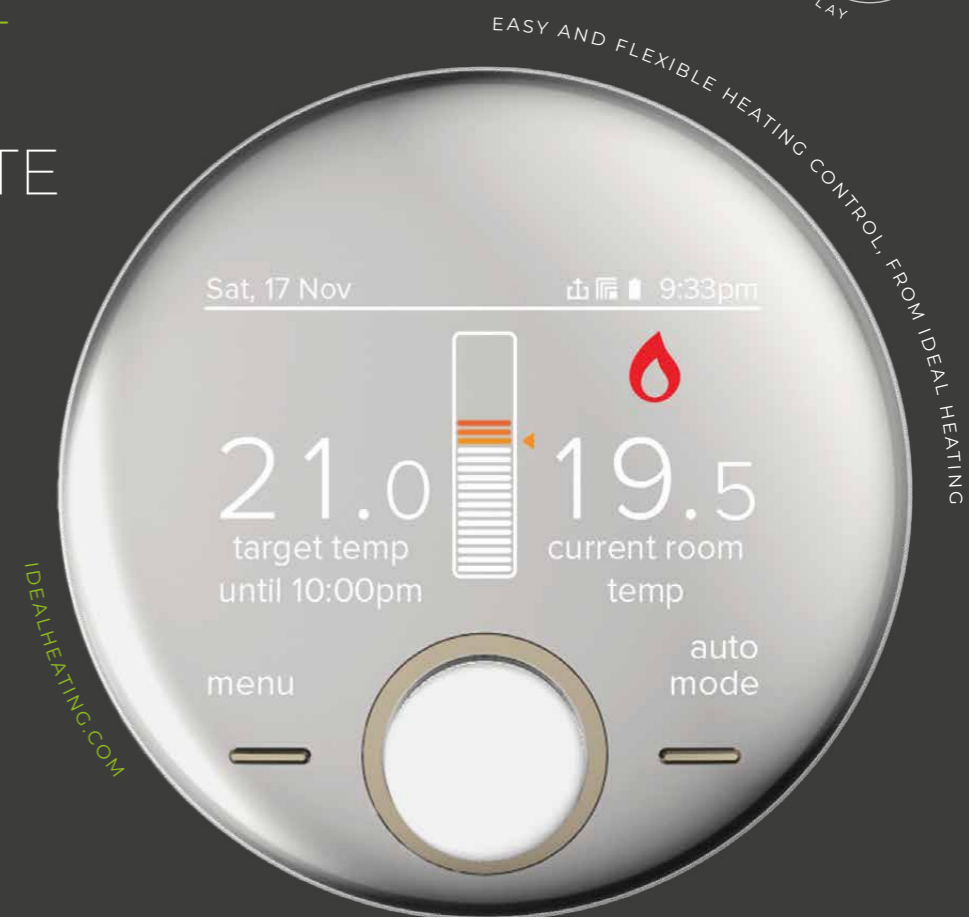

IDEALHEATING.COM

### IDEAL HALO COMBI RF

Designed specifically to work with your Ideal Boiler, Ideal Halo Combi RF is a wireless programmable room thermostat that provides simple and easy heating control.

The Halo kit includes the Smart Interface that easily plugs direct into the front of the boiler and communicates wirelessly with the Halo control.

\*Halo RF upgrade to Wi-Fi for an additional fee





# WE BELIEVE IN QUALITY SERVICE EVERY DAY

At Ideal Heating, we are committed to delivering the highest level of customer service.

You can be confident to know that you're partnering with a British manufacturer that's supported by a dedicated national service team, delivering help and advice throughout the year.



UK based call centre



7 days a week



364 days a year



Technically trained team



# WHY WORK WITH IDEAL

Our in-house design service can aid you with the domestic dwelling system design.



Full design service



Easy to install and maintain



Easy to use and customer service support

## IDEAL ACCREDITED TRAINING

Well trained employees or sub-contractors are vital for a good installation and ongoing optimum performance. Our training team have built both online and face-to-face training courses to ensure all aspects of installation, commissioning, servicing and fault finding can be dealt with quickly and efficiently.

# EXPERT ACADEMY

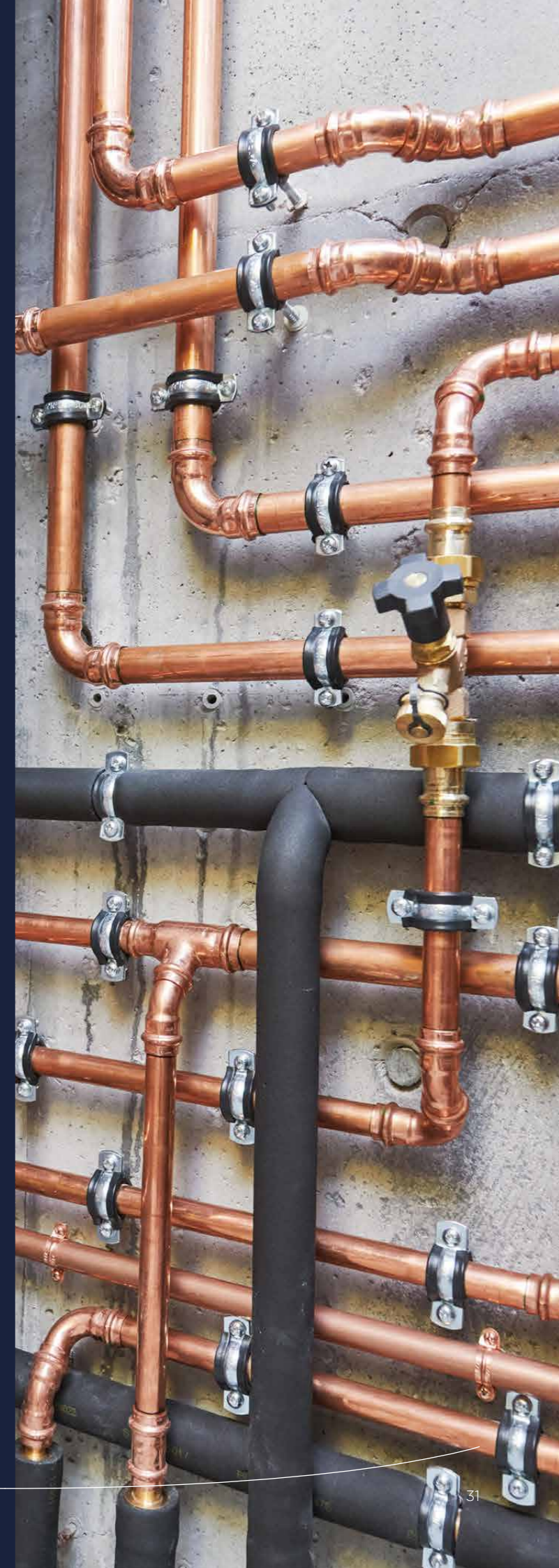





Customer Service:

**01482 498660**

Technical Help:

**01482 498663**

Ideal Heating, PO Box 103, National Avenue,  
Kingston upon Hull, East Yorkshire, HU5 4JN

E: [enquiries@idealheating.com](mailto:enquiries@idealheating.com)

[idealheating.com](http://idealheating.com) |     

**welcome to our ideology**

The information in this brochure was correct at the time of going to print. Ideal Heating reserve the right to make any modifications to product specifications or any other details, without prior notification. For further clarification, please enquire in writing to the head office address above.