

+ CONVERSION KIT

EVOMAX
30P - 80P

When replacing any part on this appliance, use only spare parts that you can be assured conform to the safety and performance specification that we require. Do not use reconditioned or copy parts that have not been clearly authorised by Ideal.

For the very latest copy of literature for specification and maintenance practices visit our website www.idealcommercialboilers.com where you can download the relevant information in PDF format.

INTRODUCTION

This kit facilitates the conversion of Propane Boilers listed below to Natural Gas.

This kit is suitable only for the following boilers listed:

Evomax 30P

Evomax 40P

Evomax 60P

Evomax 80P

Kit Contents:

Orifice	1 off
Fan Gasket	1 off
Gas Valve Outlet Gasket	1 off
Gas Sealing Washer	1 off
BCC	1 off
Data Plate	1 off

Note. Propane variants of the Evomax are Cat II_{2H3P} (20/37) and may be converted to natural gas operation only using this conversion kit.

Natural Gas variants of the Evomax are Cat I_{2H} and cannot be converted to propane operation.

Current Gas Safety (Installation & Use) Regulations or rules in force MUST be adhered to. It is law that all gas appliances are installed and serviced by a Gas Safe Registered Installer or in IE a competent person, in accordance with the regulations. Failure to install appliances correctly could lead to prosecution. It is in your own interest, and that of safety, to ensure the law is complied with.

WARNING. Always turn off the gas supply at the gas cock, and switch off and disconnect the electricity supply to the appliance before commencing work.

Refer to Installation & Servicing Instructions when carrying out the conversion

1 CASING REMOVAL

1. Pull the sides of the casing control door to open.
2. Remove the two screws retaining the front panel, lift the panel to remove.
3. Remove the two screws retaining the control panel and swing the panel down to the service position.

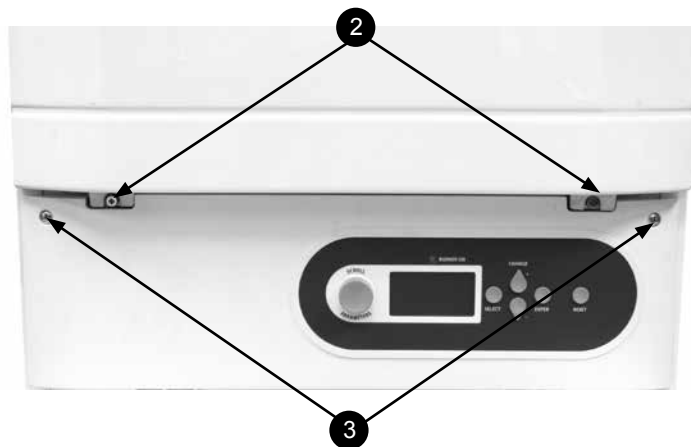

2 FITTING THE ORIFICE PLATE

1. Remove the two screws retaining the flue tube to the heat exchanger.
2. Lift the lower section of the flue upwards to disengage from the sump then twist outwards and pull down to completely remove.
3. Disconnect condensate pipe from upper flue elbow.
4. Remove the flue tube elbow fixing screws and remove elbow by pulling downwards.
5. Disconnect the electrical connections from the gas valve.
6. Disconnect the electrical connections from the fan.
7. Undo the gas valve union and retain the fibre washer.
8. Remove the four nuts/washers, (or screws depending upon boiler size) retaining the fan assembly and remove the fan assembly.

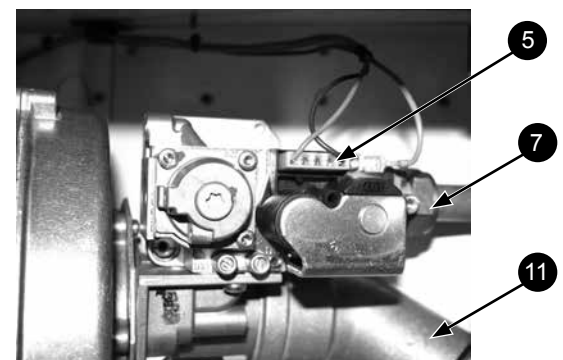
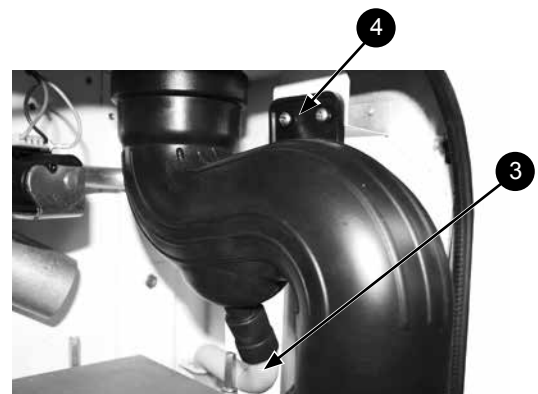

9. Remove the three screws retaining the gas valve to the venturi.
10. Remove the brass orifice plate located within the rubber-sealing washer and replace with correctly sized item supplied in the conversion kit.

Evomax 30 - Orifice 4.75

Evomax 40 - Orifice 5.25

Evomax 60 - Orifice 7.8

Evomax 80 - Orifice 8.0

The size of the orifice is stamped on the orifice plate.

When exchanging the orifice plate ensure the rubber-sealing gasket is not damaged.

11. **80KW CONVERSION ONLY:** Remove and discard air inlet elbow located on inlet to venturi.

12. Re-assemble all parts in reverse order.

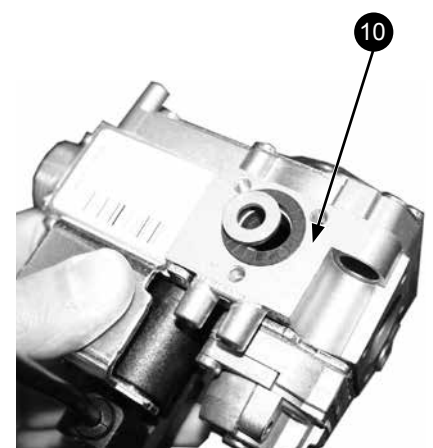
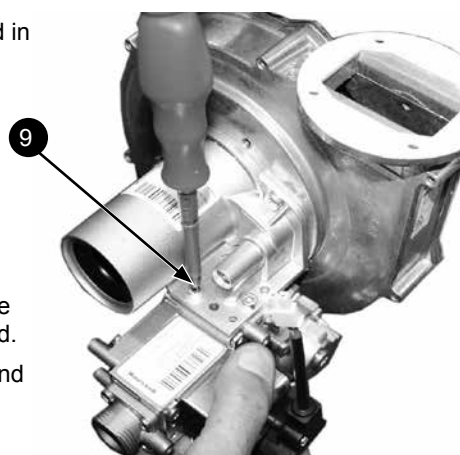

3 FITTING THE BCC

1. Remove the two screws retaining the plastic PCB cover located within the controls panel to expose the main control PCB.
2. Carefully fit the BCC to the PCB. Ensure it is correctly orientated to allow it to be plugged fully home.
3. Replace the plastic PCB cover.
4. Swing the control panel upwards and refit control panel retaining screws, refer to Frame 1.

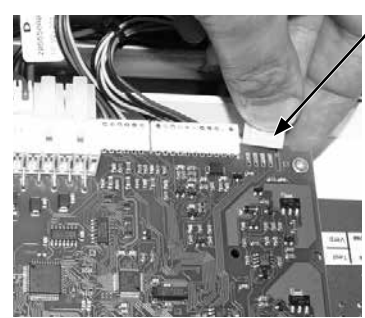
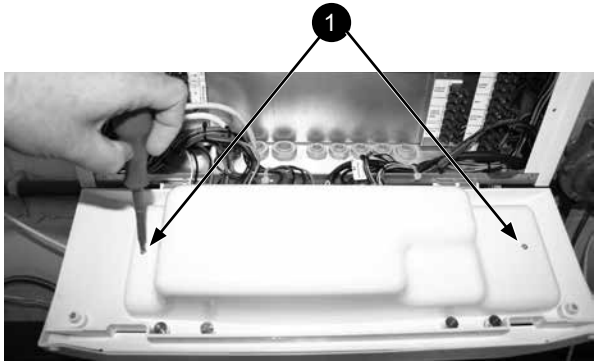

4 FINAL CHECKS

1. Test for gas soundness.
2. Check the operation of the boiler. NOTE: When initially powering boiler up reset boiler control via control panel as directed on boiler control panel display.
3. Check the gas rate and measure the combustion CO/CO₂ content. The CO/CO₂ ratio of the flue gas should not be greater than 0.004 ratio and the CO₂ should measure 9.7% (+/- 5%) when operating at maximum gas rate.
4. Following undertaking commissioning, transfer the original propane boiler serial number to the overlay label together with the date of conversion.
5. Overlay the boiler propane data plate with both the new natural gas data plate and the overlay label.

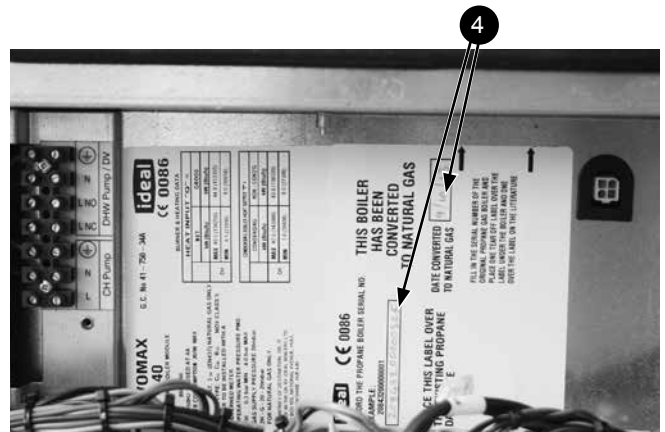

Technical Training

The Ideal Boilers Technical Training Centre offers a series of first class training courses for domestic, commercial and industrial heating installers, engineers and system specifiers. For details of courses please ring: 01482 498 432

Ideal is a trademark of Ideal Boilers.

Registered Office

Ideal Boilers Limited National Avenue, Hull, HU5 4JB.

Telephone: 01482 492 251 Fax: 01482 448 858

Registered in England no. 322137.

Ideal Boilers Limited pursues a policy of continuing improvement

in the design and performance of its products. The right is therefore reserved to vary specification without notice.



Ideal Installer/Technical Helpline: 01482 498 376
www.idealcommercialboilers.com