



INSTALLATION & SERVICING

POD HEAT INTERFACE UNIT
INDIRECT POD i305, i405, i505, i605, i705
DIRECT POD D30, D40, D50, D60

When replacing any part on this appliance, use only spare parts that you can be assured conform to the safety and performance specification that we require. Do not use reconditioned or copy parts that have not been clearly authorised by Ideal Heating.

For the very latest copy of literature for specification and maintenance practices visit our website idealheating.com where you can download the relevant information in PDF format.





WEEE DIRECTIVE 2012/19/EU
Waste Electrical and Electronic Equipment Directive

- At the end of the product life, dispose of the packaging and product in a corresponding recycle centre.
- Do not dispose of the unit with the usual domestic refuse.
- Do not burn the product.
- Remove the batteries.
- Dispose of the batteries according to the local statutory requirements and not with the usual domestic refuse.



The code of practice for the installation, commissioning & servicing of central heating systems



NOTES FOR THE INSTALLER

**FOR ANY TECHNICAL QUERIES PLEASE RING THE IDEAL
INSTALLER HELPLINE : 01482 498376**

NOTE: HEAT INTERFACE UNIT RESET PROCEDURE -
To reset the HIU press the RESET button.

DOCUMENT AMENDMENTS

Relevant Installation changes implemented in this book from Mod LevelA04 (Jan 22) to A05 (Nov 23)

Updates to Secion 2.12.3 Display Functions

Ideal Heating reserve the right to vary specification without notice

CONTENTS

<p>1. GENERAL..... 8</p> <p>1.1 Introduction..... 8</p> <p>1.2 Operation..... 8</p> <p>1.3 Safe Handling..... 9</p> <p>1.4 Optional Extra Kits..... 9</p> <p>1.5 Safety..... 9</p> <p>1.6 Safe Handling Of Substances..... 9</p> <p>1.7 Location Of HIU..... 9</p> <p>1.8 Primary Heat Supply Connection..... 10</p> <p>1.9 Water Circulation System..... 10</p> <p>1.10 Heat Interface Control Interlocks..... 10</p> <p>1.11 Electrical Supply..... 10</p> <p>1.12 HIU Dimensions, Services & Clearances..... 11</p> <p>1.13 System Requirements..... 12</p> <p>1.14 System Balancing - Central Heating..... 13</p> <p>1.15 Water Treatment..... 13</p> <p>2. INSTALLATION..... 14</p> <p>2.1 Heat Interface Unit - Exploded View..... 14</p> <p>2.2 Unpacking..... 15</p> <p>2.3 Mounting The Heat Interface Unit..... 16</p> <p>2.4 Connections..... 16</p> <p>2.5 System Filling..... 17</p> <p>2.6 Direct PICV Setting..... 19</p> <p>2.7 Electrical Connections..... 19</p> <p>2.8 Installer Wiring..... 20</p> <p>2.9 External Wiring..... 20</p> <p>2.10 Wiring Diagram..... 21</p> <p>2.11 External Wiring..... 22</p> <p>2.12 Initial Operation & Power Up..... 22</p> <p>2.13 Display Functions..... 23</p> <p>2.13.1 Menu Navigation..... 23</p> <p>2.13.2 Normal Operation..... 24</p> <p>2.13.3 Set CH Temperature 45°C - 80°C..... 25</p> <p>2.13.4 Service Modes..... 27</p> <p>2.14 Reset Procedure..... 29</p> <p>2.15 Handing Over..... 29</p>	<p>3. SERVICING..... 30</p> <p>3.1 Servicing Schedule..... 30</p> <p>3.2 Key Components - Indirect..... 31</p> <p>3.3 Key Components - Direct..... 32</p> <p>3.4 HIU Front Panel Removal / Replacement..... 33</p> <p>3.5 Draining The Heat Interface Unit..... 33</p> <p>3.6 Primary Strainer Removal, Cleaning & Replacement..... 34</p> <p>3.7 CH Pressure Gauge Replacement (Indirect Only)..... 34</p> <p>3.8 CH Expansion Vessel Recharging & Replacement (Indirect Only)..... 35</p> <p>3.9 DHW Water Hammer Arrestor Recharging & Replacement..... 35</p> <p>3.10 CH Circulation Pump Head Replacement..... 36</p> <p>3.11 Pump Automatic Air Vent Removal & Replacement..... 36</p> <p>3.12 Internal Insulation Front Section Removal & Replacement..... 37</p> <p>3.13 DHW Plate Heat Exchanger Removal & Replacement... 38</p> <p>3.14 CH Plate Heat Exchanger Removal & Replacement..... 39</p> <p>3.15 CH Water Pressure Switch Removal & Replacement..... 40</p> <p>3.16 Primary Return Thermistor..... 40</p> <p>3.17 Domestic Hot Water Thermistor..... 41</p> <p>3.18 CH Flow & Return Thermistor..... 41</p> <p>3.19 CH Pressure Relief Valve..... 42</p> <p>3.20 PCB Removal & Replacement..... 43</p> <p>3.21 DHW Flow Regulator..... 44</p> <p>3.22 DHW Flow Manifold With Integrated Turbine Assembly Replacement..... 44</p> <p>3.23 DHW PICV..... 45</p> <p>3.24 CH PICV..... 45</p> <p>3.25 Heat Meter Installation..... 46</p> <p>4. FAULT FINDING..... 48</p> <p>4.1 Display Faults..... 48</p> <p>4.2 Additional Fault Finding..... 50</p> <p>4.3 Fault Codes - Numeric..... 51</p> <p>5. SPARE PARTS..... 52</p> <p>6. COMMISSIONING..... 53</p>
--	---

SECTION 1 - GENERAL

Table 1 - General Data

Models		Indirect					Direct			
		POD i305	POD i405	POD i505	POD i605	POD i705	POD D30	POD D40	POD D50	POD D60
Inlet Connection	Domestic Hot Water	22mm copper								
Outlet Connection	Domestic Hot Water	22mm copper								
Flow Connection	Central Heating	22mm copper								
Return Connection	Central Heating	22mm copper								
Flow Connection	Primary	22mm copper								
Return Connection	Primary	22mm copper								
Pressure Relief Valve Safety Outlet	Central Heating	15mm copper								
Maximum Working Pressure (Sealed System) Central Heating CH	bar (PSI) (kPa)	2.5 (36.3)					6.0 (87.0) (600)			
Minimum Operational Central Heating Pressure (pressure switch activation off)	bar (PSI) (kPa)	0.5 (7.25)					N/A			
Maximum Operational Central Heating Temperature (dependant on primary supply)	°C	80°C @ 85°C Primary								
Maximum Domestic Hot Water Inlet Pressure (DHW)	bar (PSI) (kPa)	10 (145) (1000)								
Minimum Domestic Hot Water Inlet Pressure*	bar (PSI) (kPa)	0.8 (11.6) (80)	1.3 (18.9) (130)			0.8 (11.6) (80)	1.3 (18.9)** (130)**			
Minimum DHW Inlet Pressure to operate at 0.6 bar system pressure	bar (PSI) (kPa)	0.5 bar (7.25) (50)								
Maximum Operational DHW Temperature (dependant on primary supply)	°C	65°C @ 70°C to 85°C Primary								
Maximum Primary Supply Pressure	bar (PSI) (kPa)	16 (232) (1600)					6.0 (87.0) (600)			
Maximum Primary Supply Temperature	°C	85°C								
Minimum Operational Primary Differential Pressure*	bar (PSI) (kPa)	0.50 (7.25) (50)								
Maximum Operational Primary Differential Pressure*	bar (PSI) (kPa)	6.0 (87) (600)								
Maximum Central Heating (Differential)	bar (PSI) (kPa)	N/A					6.0 (87) (600)			
Minimum Central Heating (Differential)	bar (PSI) (kPa)	N/A					0.5 (7.3) (50)			
Expansion Vessel Volume	Litres	8					N/A			
Expansion Vessel Pre-Charge Pressure	Bar	0.75					N/A			
Electrical Supply		230 V ~ 50 Hz								
Power Consumption	W	94	101	114			94	101	114	
Fuse Rating		All models: External : 3A, Internal : T4A HRC L250 V								
Water Content Domestic Hot Water	litre (gal)	0.710 (0.16)	0.79 (0.17)	0.94 (0.21)	1.01 (0.22)	1.2 (0.32)	0.710 (0.16)	0.79 (0.17)	0.94 (0.21)	1.01 (0.22)
Water Content Primary	litre (gal)	1.07 (0.24)	1.21 (0.27)	1.29 (0.28)	1.47 (0.32)	1.73 (0.46)	1.07 (0.24)	1.21 (0.27)	1.29 (0.28)	1.47 (0.32)
Water Content Central Heating	litre (gal)	1.01 (0.22)					N/A			
Packaged Weight	kg	32.1	32.5	32.9	33.4	33.7	26.0	26.4	26.8	27.3
Maximum Installation Weight	kg	29.0	29.4	29.8	30.3	30.6	22.9	23.3	23.7	24.2
HIU Casing Size Height (including first fix)	mm	735								
HIU Casing Size Width	mm	475								
HIU Casing Size Depth	mm	330								

6 *Required for maximum flow rate. HIU operates down to 2 l/min DHW delivery
 ** In areas of low water pressure the Flow Regulator can be removed

SECTION 1 - GENERAL

Table 2 - Performance Data

Models	Indirect					Direct				
	POD i305	POD i405	POD i505	POD i605	POD i705	POD D30	POD D40	POD D50	POD D60	
Primary Supply Temperature @ 50kPa	70°C									
Primary Flow Rate	l/s	0.188	0.265	0.314	0.310	0.319	0.188	0.265	0.314	0.310
Primary Return Temperature	°C	30.3	31.7	30.0	25.1	22.0	30.3	31.7	30.0	25.1
Primary Pressure Drop	kPa	52	51	48	51	54	52	51	48	51
DHW Flow Rate (60°C @ 50K rise)	l/min	9.3	11.9	15.4	19.4	24.5	9.3	11.9	15.4	19.4
DHW Output (60°C @ 50K rise)	kW	30.6	41.0	50.7	54.9	61.6	30.6	41.0	50.7	54.9
Primary Flow Rate	l/s	0.16	0.23	0.27	0.31	0.33	0.16	0.23	0.27	0.31
Primary Return Temperature	°C	24.3	27.1	25.9	18.6	23.0	24.3	27.1	25.9	18.6
Primary Pressure Drop	kPa	51	50	53	49	59	51	50	53	49
DHW Flow Rate (55°C @ 45K rise)	l/min	9.7	13.3	16.7	19.0	22.4	9.7	13.3	16.7	19.0
DHW Output (55°C @ 45K rise)	kW	30.7	39.9	50.6	57.9	63.4	30.7	39.9	50.6	57.9
Primary Flow Rate	l/s	0.16	0.21	0.26	0.29	0.32	0.16	0.21	0.26	0.29
Primary Return Temperature	°C	22.7	23.57	22.85	23.2	22.3	22.7	23.57	22.85	23.2
Primary Pressure Drop	kPa	53	51	51	54	55	53	51	51	54
DHW Flow Rate (50°C @ 40K rise)	l/min	11.6	14.9	18.4	21.3	25.5	11.6	14.9	18.4	21.3
DHW Output (50°C @ 45K rise)	kW	31.0	39.3	50.6	56.9	63.9	31.0	39.3	50.6	56.9
Primary Flow Rate	l/s	0.12	0.18	0.22	0.26	0.29	0.12	0.18	0.22	0.26
Primary Return Temperature	°C	18.2	20.3	19.2	20.4	20.8	18.2	20.3	19.2	20.4
Primary Pressure Drop	kPa	57	52	48	47	50	57	52	48	47
DHW Flow Rate (45°C @ 35K rise)	l/min	11.1	15.3	19.5	21.8	24.6	11.1	15.3	19.5	21.8
DHW Output (45°C @ 35K rise)	kW	26.4	35.3	46.9	51.1	58.4	26.4	35.3	46.9	51.1
CH Flow Rate (65°C - 35°C)	l/min	4.29					N/A			
CH Output (65°C - 35°C)	kW	6.4					N/A			
CH Flow Rate (70°C - 40°C)	l/min	4.07					N/A			
CH Output (70°C - 40°C)	kW	5.29					N/A			
ELECTRICAL										
Electrical Power Supply Voltage	AC Voltage	230								
Frequency	Hz	50								
Maximum Power Consumption	W	53.1					8.6			
Standby Power Consumption	W	2.8								
Appliance Protection Rating	IP	20								
Sound Power Level Indoors (L _{WA})	dB	48.6					37.9			

The Indirect products within this range are BESA tested. Test reports can be found at www.thebesa.com/ukhiu

Direct central heating performance is dependent on primary operating conditions.

SECTION 1 - GENERAL

1. GENERAL

1.1 INTRODUCTION

The Ideal POD range are wall mounted, electronically controlled, Heat Interface Units (HIU) whose energy is provided from district or community-based heating systems. Examples of central plant systems include centralised HIUs, district heating or central energy systems using renewable or hybrid energy sources.

HIUs provide accurately controlled heating and hot water delivery to meet the user's demands. These units are available with indirect domestic hot water and central heating (Indirect range) or with indirect domestic hot water and direct central heating (Direct range) formats.

INDIRECT RANGE

- Ideal POD i305 = 30kW DHW output with 5kW indirect CH output performance
- Ideal POD i405 = 40kW DHW output with 5kW indirect CH output performance
- Ideal POD i505 = 50kW DHW output with 5kW indirect CH output performance
- Ideal POD i605 = 60kW DHW output with 5kW indirect CH output performance
- Ideal POD i705 = 70kW DHW output with 5kW indirect CH output performance

DIRECT RANGE

- Ideal POD D30 = 30kW DHW output with direct CH output performance
- Ideal POD D40 = 40kW DHW output with direct CH output performance
- Ideal POD D50 = 50kW DHW output with direct CH output performance
- Ideal POD D60 = 60kW DHW output with direct CH output performance

The HIU is supplied fully assembled, incorporating electronic controls, Primary Pressure Independent Control Valves (PICV), a Domestic Hot Water (DHW) Plate Heat Exchanger (PHE), shock arrestor, strainer, control turbine and thermistors.

Indirect units have an additional circulating pump, pressure gauge, safety valve and Central Heating (CH) expansion vessel.

The HIU is provided with a fully insulated heat transfer section reducing heat loss with an isolation connection manifold and CH filling loop (Indirect only).

User Features

User controls allow the required temperatures to be selected for hot water and for heating.

The HIU features a DHW Preheat facility, frost protection, daily pump and PICV exercise.

Installer Features

- **Primary return temperature limiting** - this feature is intended to be used by commissioning engineers and restricts the return temperature on the primary by not opening the PICV to allow any more heat energy than that required to deliver the pre-set primary return temperature. This may reduce available output and ensures the heat network system meets its design efficiency requirement.
- **Concrete slab drying** - this facility allows the HIU to be operated at a low temperature suitable to assist the drying of a concrete floor where under-floor heating is installed without causing cracking.

- **PICV (s) anti seize function** - If the PICV has not operated in a 24 hour period the control will operate the valve briefly to prevent the valve from becoming stuck in position.
- **Construction** - the HIU casing and front door is of white painted mild steel, the user controls are located behind the lower hinged door. The internal control panel is polymer-based construction. There is provision to fit an optional heat meter to record the energy consumption.
- All the internal plate heat exchangers are stainless steel.
- The central heating circuit for all models is suitable for connection to fully pumped, sealed heating systems ONLY.
- Adequate arrangements for completely draining the system by provision of drain cocks MUST be provided in the installation pipework.
- Pipework from the HIU can be routed upwards or downwards.
- The HIU has a separate isolation valve connection system and filling loop (Indirect only) that must be fitted prior to HIU installation.
- Additional kits are available to aid system flushing and filling.
- Be sure to follow Ideal installation and maintenance guide for correct method of installation.

Data Plate

The HIU model, serial number and other key operational data can be found on the data plate that is located inside the left-hand side panel of the case.

1.2 OPERATION

The HIU operates on DHW priority. During a CH demand period if a DHW demand is detected the HIU will deliver the required DHW, returning to CH mode only when the DHW demand ends. The HIU has a DHW pre-heat function for a faster response to demand for hot water. This only operates if the "PREHEAT" function is selected and the display reads "HOT WATER PREHEAT ON".

The delivery temperature of the DHW is controlled by the PICV. This controls the flow of the primary water to the DHW plate heat exchanger delivering the required temperature as set on the user control.

When there is a demand for CH, the heating system is supplied at the selected temperature of between 30°C and 80°C, until the CH demand is deactivated or there is a DHW demand. The flow temperature to the heating system is controlled by the heating circuit PICV. This controls the flow of the primary water to the central heating plate heat exchanger delivering the required temperature as set on the user control.

For DHW draw off data please reference the performance tables in Table 2.

The DHW draw off rate specified in Table 2 is the nominal that the HIU flow regulator will supply. Due to system variations and seasonal temperature fluctuations DHW flow rates/temperature rise will vary, requiring adjustment at the draw off tap.

At low DHW draw-off rates the maximum temperature may temporarily exceed 65°C (i.e. for a period of less than 10 seconds).

The HIU features a comprehensive diagnostic system which gives detailed information on the operational status, and performance of key components to aid commissioning and fault finding.

SECTION 1 - GENERAL

1.3 SAFE HANDLING

This HIU may require 2 or more operatives to move it to its installation site, remove it from its packaging base and during movement into its installation location. Manoeuvring the HIU may include the use of a sack truck and involve lifting, pushing and pulling.

Caution should be exercised during these operations.

Operatives should be knowledgeable in handling techniques when performing these tasks and the following precautions should be considered:

- Grip the HIU at the base.
- Be physically capable.
- Use personal protective equipment as appropriate, e.g. gloves, safety footwear etc.

During all manoeuvres and handling actions, every attempt should be made to ensure the following unless unavoidable and/or the weight is light:

- Keep back straight.
- Avoid twisting at the waist.
- Avoid upper body/top heavy bending.
- Always grip with the palm of the hand.
- Use designated hand holds.
- Keep load as close to the body as possible.
- Always use assistance if required.

1.4 OPTIONAL EXTRA KITS

The following optional extra kits are available for the HIU POD Direct & Indirect models:

- Credit Control Valve Kit
- Flushing Bypass Permanent Kit
- Union Kit R3/4 to G1
- Flushing Bypass Temporary Kit
- Heat Meter Wired MBUS Kit
- Heat Meter Wireless MBUS Kit
- Room Temperature Sensor
- Open Therm Room Control
- Ideal System Filter

1.5 SAFETY

The HIU must be installed by a competent person trained in Heat Network product installations, in accordance to Heat Network code of practice (installation and use) regulations or other rules in force.

The appliance is suitable only for installation in GB and IE and should be installed in accordance with the rules in force.

It must be carried out in accordance with the relevant requirements of the:

- Heat Networks code of practice (Installation and Use) Regulations
- Appropriate Building Regulations, either: The Building Regulations, The Building Regulations (Scotland), Building Regulations (Northern Ireland).
- Water Fittings Regulations or Water byelaws in Scotland. Current I.E.E. Wiring Regulations.
- Where no specific instructions are given, reference should be made to the relevant British Standard Code of Practice.
- The current Building Regulations and reference should be made to the current ETCI rules for electrical installation.
- Detailed recommendations are contained in the following British Standard Codes of Practice:

CIBSE CP1 (2020) Heat Network code of practice.

BS EN. 12828 Heating Systems in buildings: Design for water-based heating systems.

BS EN 12831 Heating Systems in buildings: Method for calculation of the design heat load.

BS EN 14336 Heating Systems in buildings: Installation and commissioning of water-based heating systems.

Health & Safety Document No. 635.

The Electricity at Work Regulations, 1989.

The manufacturer's notes must NOT be taken, in any way, as overriding statutory obligations.

IMPORTANT. These appliances are CE & UKCA certificated for safety and performance. It is therefore important that no external control devices, e.g. economisers etc., are directly connected to these appliances unless covered by these Installation and Servicing Instructions or as otherwise recommended by Ideal Heating in writing. If in doubt, please enquire.

Any direct connection of a control device not approved by Ideal Heating could invalidate the certification and the normal appliance warranty.

1.6 SAFE HANDLING OF SUBSTANCES

No asbestos, mercury or CFCs are included in any part of the HIU or its manufacture.

1.7 LOCATION OF HIU

The HIU must be installed on a flat and vertical internal wall, capable of adequately supporting the weight of the HIU and any ancillary equipment.

The HIU may be fitted on a combustible wall and insulation between the wall and the HIU is not necessary, unless required by the local authority.

For electrical safety reasons there must be no access available from the back of the HIU.

The HIU must not be fitted outside.

Bathroom Installations

This appliance is rated **IP20**.

The HIU may be installed in any room or internal space, although particular attention is drawn to the requirements of the current IEE (BS 7671) Wiring Regulations and the electrical provisions of the Building Regulations applicable in Scotland, with respect to the installation of the HIU in a room or internal space containing a bath or shower. For IE reference should be made to the current ETCI rules for electrical installations and I.S. 813:2002.

If the appliance is to be installed in a room containing a bath or shower then, providing water jets are not going to be used for cleaning purposes (as in communal baths/showers), the appliance must be installed beyond Zone 2, as detailed in BS 7671.

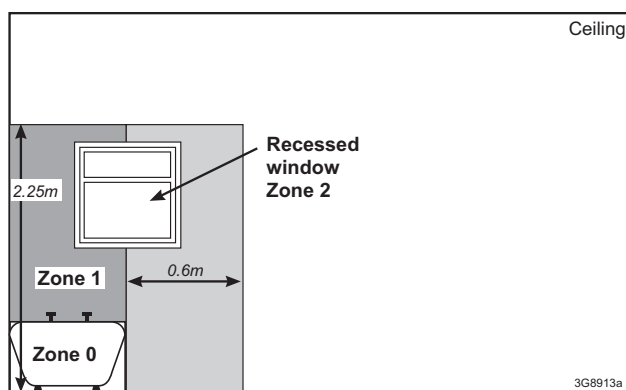

Compartment Installations

A compartment used to enclose the HIU should be designed and constructed specially for this purpose.

An existing cupboard or compartment may be used, provided that it is modified for the purpose.

Braces for compartments must be easily removable for service access. In both cases, details of essential features of cupboard / compartment design, including airing cupboard installation, are to conform to the following:

BS 6798 (Temperature control ventilation is required - see 'Air Supply' for details).

The position selected for installation MUST allow adequate space for servicing in front of the HIU, this can be by means of an opening door.

For the minimum clearances required for safety and subsequent service, see the wall mounting template and sections below. In addition, sufficient space may be required to allow lifting access to the wall mounting plate.

Dependant on the size and insulation aspects of the cupboard or room, air ventilation may be required to ensure the ambient air around the product does not exceed 35°C. If it may exceed 35°C then additional air vents and ventilation will be required in the room or internal space in which the HIU is installed.

Failure to provide an ambient operational environment of less than 35°C may invalidate the warranty.

1.8 PRIMARY HEAT SUPPLY CONNECTION

The supplier of the Heat Network Energy must ensure the supply remains within the operational requirements of the HIU fitted.

It must conform to all codes of practice.

Any additives and dosing systems must conform to the water treatment directive for that area of installation.

Any third-party system control function (Heat Network or Credit Control etc.) will not be the responsibility of the HIU manufacturer.

Any heat metering data collection and billing is the sole responsibility of the metering service provider.

1.9 WATER CIRCULATION SYSTEM

IMPORTANT.

A minimum length of 1 metre of copper pipe MUST be fitted to both flow and return connections from the HIU before connection to any plastic piping.

The central heating system should be in accordance with **BS 7593** Code of practice for the preparation, commissioning & maintenance of domestic central heating and cooling water systems.

1.10 HEAT INTERFACE CONTROL INTERLOCKS

Central heating system controls should be installed to ensure that the HIU has no demand when there is no requirement from the system, in compliance with Building Regulations.

Heating systems utilising full thermostatic radiator valve control of temperature in individual rooms should also be fitted with a room thermostat controlling the temperature in a space served by radiators not fitted with such a valve.

When thermostatic radiator valves are used, the space heating temperature control over a living / dining area or hallway having a heating requirement of at least 10% of the minimum HIU heat output should be achieved using a room thermostat, whilst other rooms are individually controlled by thermostatic radiator valves.

However, if the system employs thermostatic radiator valves on all radiators, or two port valves, then a bypass circuit must be fitted with an automatic bypass valve to ensure a flow of water should all valves be in the closed position.

1.11 ELECTRICAL SUPPLY

WARNING.

This appliance must be earthed.

Wiring external to the appliance MUST be in accordance with the current I.E.E. (BS 7671) Wiring Regulations and any local regulations which apply. For IE reference should be made to the current ETCI rules for electrical installations.

The mains supply to the HIU and system wiring centre shall be through one common fused double pole isolator and where practical replacement installations, the isolator shall be situated adjacent to the appliance.

SECTION 1 - GENERAL

1.12 HIU DIMENSIONS, SERVICES & CLEARANCES

HIU Dimensions, Services & Clearances

The HIU connections are made on to the HIU first fix kit valve connection tails.

These are to be connected by suitable piping diameters. Please see table overleaf for reference.

A clearance around the unit is required of at least:

Top 100mm

Sides 20mm

Bottom of wall bracket 80mm

Front Clearance

The minimum front clearance when built into a cupboard is 25mm from the outward opening cupboard door.

600mm overall clearance is still required with a cupboard door open, to allow for servicing.

Bottom Clearance

The bottom clearance from the underside of the wall bracket should be a minimum of 80mm in order to allow access to the HIU isolation valves and the CH filling loop system.

Refer to the wall mounting template for further information.

Dimensions

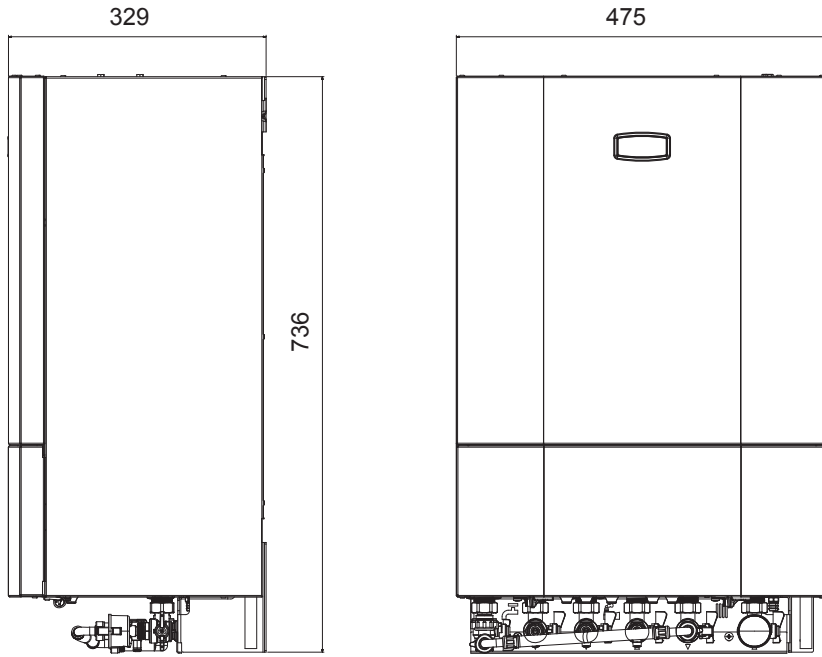

Clearances

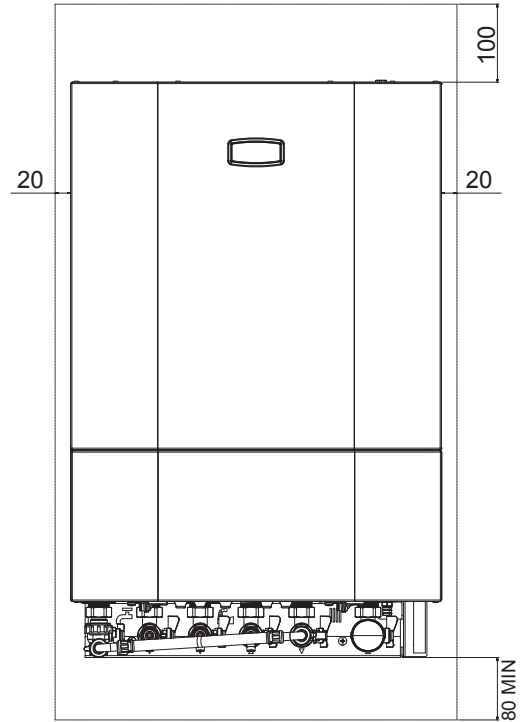

Direct

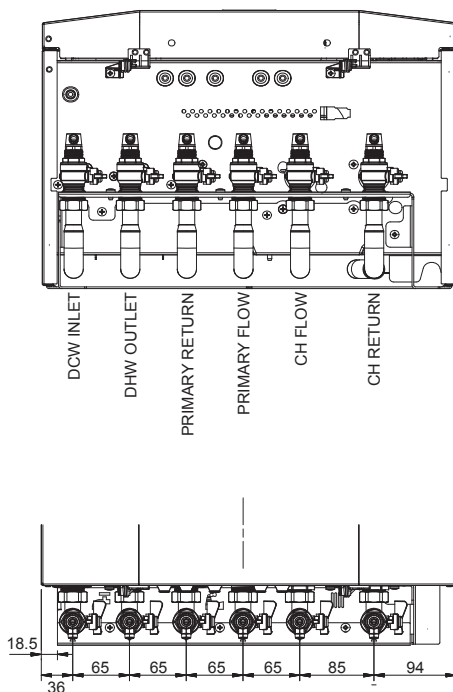

Indirect

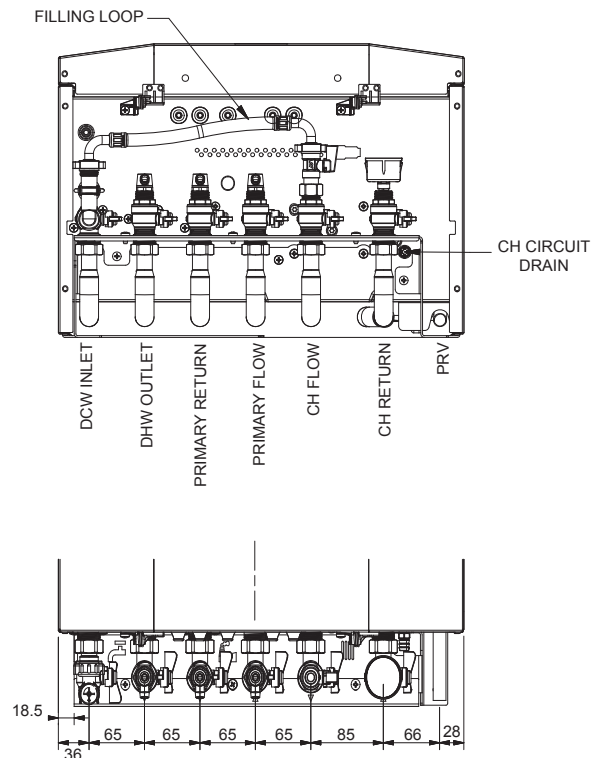

SECTION 1 - GENERAL

1.13 SYSTEM REQUIREMENTS

Notes

- a. The method of filling, refilling, topping up or flushing sealed secondary circuits from the mains via a temporary hose connection is only allowed if acceptable to the local water authority.
- b. Antifreeze fluid, corrosion and scale inhibitor fluids suitable for use with HIU's should be compatible with all the material present in the appliance.

General

1. The installation must comply with all relevant national and local regulations.
2. The installation should be designed to work with flow temperatures of up to 84 °C.
3. All components of the indirect central heating system must be suitable for a working pressure of 3 bar and a maximum design temperature of 110 °C. Extra care should be taken in making all connections so that the risk of leakage is minimised.

The following components are incorporated within the appliance:

- a. Circulating pump.
- b. Safety valve, with a non-adjustable preset lift pressure of 3 bar.
- c. Pressure gauge, covering a range of 0 to 4 bar.
- d. An 8-litre expansion vessel, with an initial charge pressure of 0.75 bar.

Note: Direct units system must be capable of withstanding the maximum design pressures of the attached primary system.

Guidance on vessel sizing is given in table below.

Safety valve setting	bar	3.0	
Vessel charge pressure	bar	0.5 to 0.75	
System pre-charge pressure	bar	None	1.0
System volume (litres)		Expansion vessel volume (litres)	
25		1.6	1.8
50		3.1	3.7
75		4.7	5.5
100		6.3	7.4
125		7.8	9.2
150		9.4	11.0
175		10.9	12.9
190		11.9	14.0
200		12.5	14.7
250		15.6	18.4
300		18.8	22.1
For other system volumes multiply by the factor across		0.063	0.074

Domestic Hot Water

1. The DHW service must be in accordance with BS 6700.
2. Refer to Table 1 for minimum and maximum working pressures. In areas of low mains water pressures the domestic hot water regulator may be removed from the DHW flow turbine manifold. Refer to Section 3.21. The HIU will require the flow rate to be set to obtain a temperature rise of 35°C at the tap furthest from the HIU.
3. The HIU is suitable for connection to most types of washing machine and dishwasher appliances.
4. If the shower/mixer valve does not incorporate non-return valves the following must be followed:
 - a. The cold inlet to the HIU is fitted with an approved anti-vacuum or syphon non-return valve.
 - b. Hot and cold water supplies to the shower are of equal pressure.
5. **Hard Water Areas**
Refer to Section 1.15 Water Treatment.

IMPORTANT. Provision has been made to accommodate the expansion of DHW contained within the unit by the use of a fitted expansion mini vessel in the HIU on the outlet of the DHW circuit.

Cold water, rising main and pipework in exposed areas need to be suitably lagged to prevent freezing.

Water Flow Rate and Pressure Loss

Max CH Output	kW	5
Water flow rate	l/min	17.3
	(gal/min)	(3.8)
Temperature Differential	°C	20
Head available for system	m.w.g. (ft.w.g.)	3.4 (11.1)

SECTION 1 - GENERAL

1.14 SYSTEM BALANCING - CENTRAL HEATING

The HIU does not normally need a bypass but at least some radiators on the heating circuit, of load of at least 10% of the minimum HIU output, must be provided with twin lockshield valves so that this minimum heating load is always available. See note regarding thermostatic radiator valves in 1.10 Heat Interface Control Interlocks

Note: Systems incorporating zone valves which could completely cut off the flow through the system must also include a bypass.

BALANCING

1. Open the manual and thermostatic valves and lockshield valves on all radiators.
2. Turn up room thermostat to create a heat demand and adjust the lockshield valve on each radiator to achieve the required temperature differential (20 °C)(Temperature difference between the flow and return of the radiator) and fit the blanking caps on the lockshield valves.
3. Set any bypass valves or bypass radiators.
4. Set the room thermostats and radiator thermostats to the desired temperatures.

1.15 WATER TREATMENT

CENTRAL HEATING

The Ideal range of indirect HIU's have a stainless steel CH plate heat exchanger.

IMPORTANT.

The application of any other treatment to this product may render the guarantee of Ideal Heating invalid. The use of the optional Ideal Filter will aid against the build up of iron oxide debris, however the water treatments listed below are also recommended by Ideal Heating.

Ideal Heating recommend Water Treatment in accordance with the Guidance Notes on Water Treatment in Central Heating Systems.

If water treatment is used Ideal Heating recommend only the use of SCALEMASTER SM-1 PRO, FERNOX, MBI, ADEY MC1, SENTINEL X100 or CALMAG CM100 inhibitors and associated water treatment products, which must be used in accordance with the manufacturers' instructions.

Notes.

1. *It is most important that the correct concentration of the water treatment products is maintained in accordance with the manufacturers' instructions.*
2. *If the HIU is installed in an existing system any unsuitable additives MUST be removed by thorough cleansing. BS 7593 details the steps necessary to clean a domestic heating system.*
3. *In hard water areas, treatment to prevent lime scale may be necessary - however the use of artificially softened water is NOT permitted.*
4. *Under no circumstances should the HIU be operated before the system has been thoroughly flushed.*

DOMESTIC HOT WATER

In hard water areas where mains water can exceed 200ppm Total Hardness (as defined by BS 7593 Table 2) a scale reducing device should be fitted to the HIU's cold supply within the requirements of the local water company.

Ideal Heating recommend the use of Fernox Quantomat, Sentinel Combiguard, Calmag CalPhos I scale reducing devices or Scalemaster In-line Scale Inhibitor branded Ideal, which must be used in accordance with the manufacturers' instructions.

For Further information contact:

Fernox
www.fernox.com

Tel: +44 (0) 3301 007750

Sentinel Performance Solutions
www.sentinelprotects.com
Tel: +44 (0) 1928 704330

Scalemaster Water Treatment Products
www.scalemaster.co.uk
Tel: +44 (0) 1785 811636

Calmag Ltd.
www.calmagltd.com
Tel: +44 (0) 1535 210320

Adey
www.adey.com
Tel: +44 (0) 1242 546700

SECTION 2 - INSTALLATION

2. INSTALLATION

The following steps assume that the first fix bracketry has been pre-installed as per the guidance within the First Fix manual.

2.1 HEAT INTERFACE UNIT - EXPLODED VIEW

Note: Item numbers are linked to the spares list

- | | | | |
|---------------------------------|-----------------------------|--------------------------------------|------------------------------------|
| 101 DCW Manifold Assembly | 129 Primary Flow Pipe DHW 1 | 200 Flow Turbine Sensor | 501 Bracket Expansion Vessel Lower |
| 102 Drain Valve | 130 Primary Flow Pipe DHW 2 | 201 Thermistor (Wet Sided) | 504 Front Panel |
| 103 DHW Manifold | 131 Primary Flow Pipe CH 1 | 202 Thermistor (Wet Sided) | 505 Casing Screw Kit |
| 104 Mini Expansion Vessel | 132 Primary Flow Pipe CH 2 | 203 Clip on Thermistor for 18mm Pipe | 506 Ideal Heating Badge |
| 105 Primary Return Manifold | 133 Primary Return Pipe | 204 Cable Entry Kit | 507 Door |
| 106 Pressure Test Points | 136 CH Flow Pipe Indirect | 205 PICV Actuator | 510 Model Badge Kit Direct |
| 109 Primary Strainer Basket | 137 CH Return Pipe Indirect | 207 Heat Meter Wired MBUS Kit | 512 Front EPP |
| 110 Primary Strainer Seal | 138 CH Return PIPE Direct | 301 Control Box Fixings & Hinge Kit | |
| 113 Expansion Vessel | 139 CH Flow Pipe Direct | 302 Control Box Retention Clip | |
| 126 Hydroblock Complete Kit HIU | 141 Primary Return Tee | 500 Bracket Expansion Vessel | |
| 127 DCW Pipe | 142 DHW PICV | | |
| 128 DHW Pipe | 143 CH PICV | | |

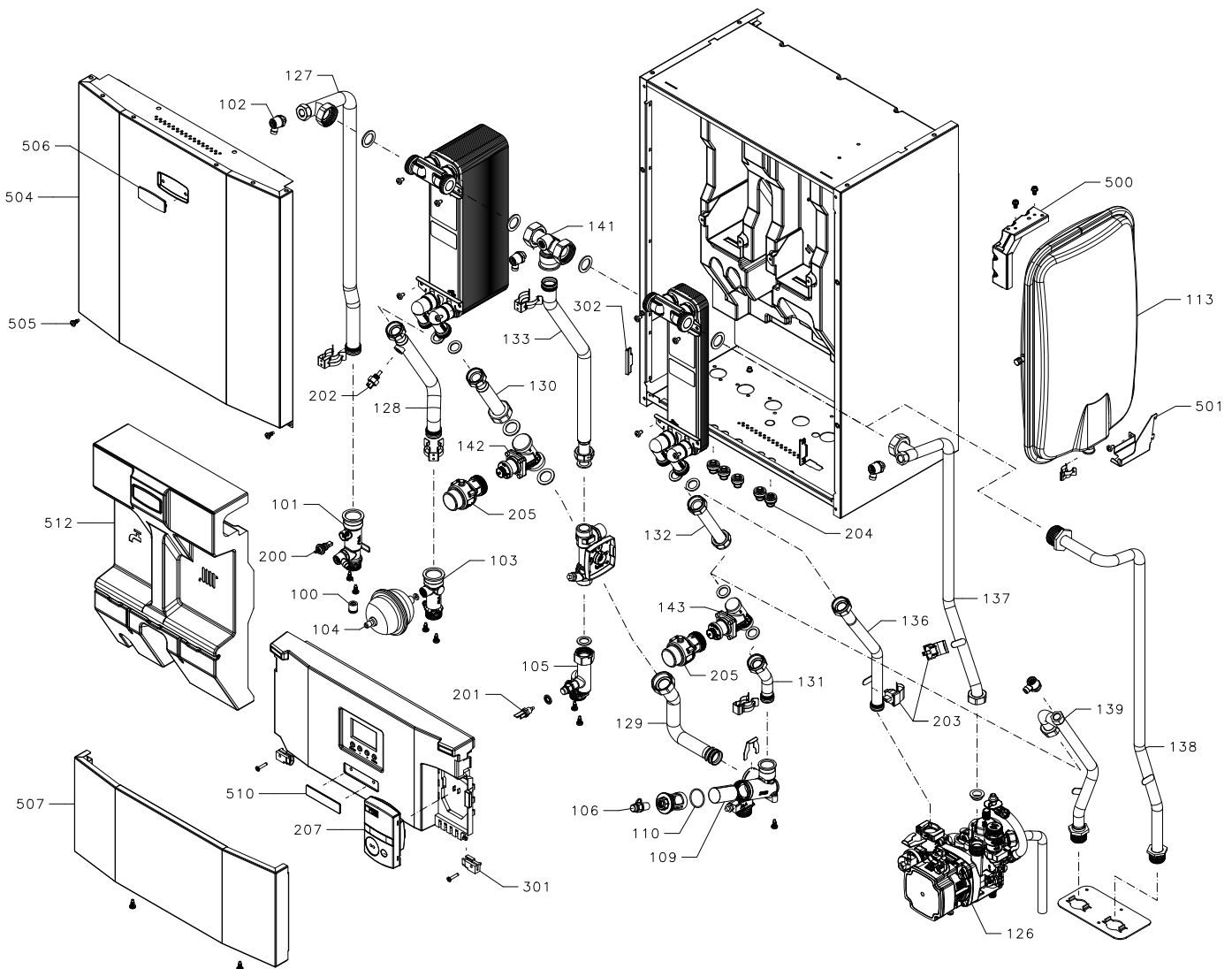

SECTION 2 - INSTALLATION

2.2 UNPACKING

The POD HIU is supplied in 2 parts, the First Fix Kit and the main appliance. For further details on the First Fix Kit, refer to the instructions enclosed in the kit

To unpackage the appliance:

1. Remove the straps from the outside of the packaging.
2. Lift off the outer sleeve.
3. Remove the literature pack and store for future reference.
4. Remove the front pad.
5. Optional: Lift the appliance into the upright position, ensuring it sits on the cardboard base, to prevent damage to the pressure relief out pipe and valve.

Care MUST be taken to support the appliance during lifting. This should be done by 2 people due to the weight of the unit.

DO NOT LIFT THE APPLIANCE VIA THE CARDBOARD PACKAGING.

DO NOT SIT THE APPLIANCE ON THE BASE CONNECTIONS WITHOUT THE PACKAGING IN PLACE. THIS WILL RESULT IN DAMAGE TO THE CONNECTION POINTS, PRV PIPE & HINGES.

6. Remove the top pad packaging.
7. Remove the rear packaging tray by sliding it out from under the bottom pad.
Care MUST be taken to ensure the appliance does not rock forwards or backwards.
8. Check the appliance. It is now ready for lifting into position.

Packaging materials should be recycled in accordance with regional requirements.

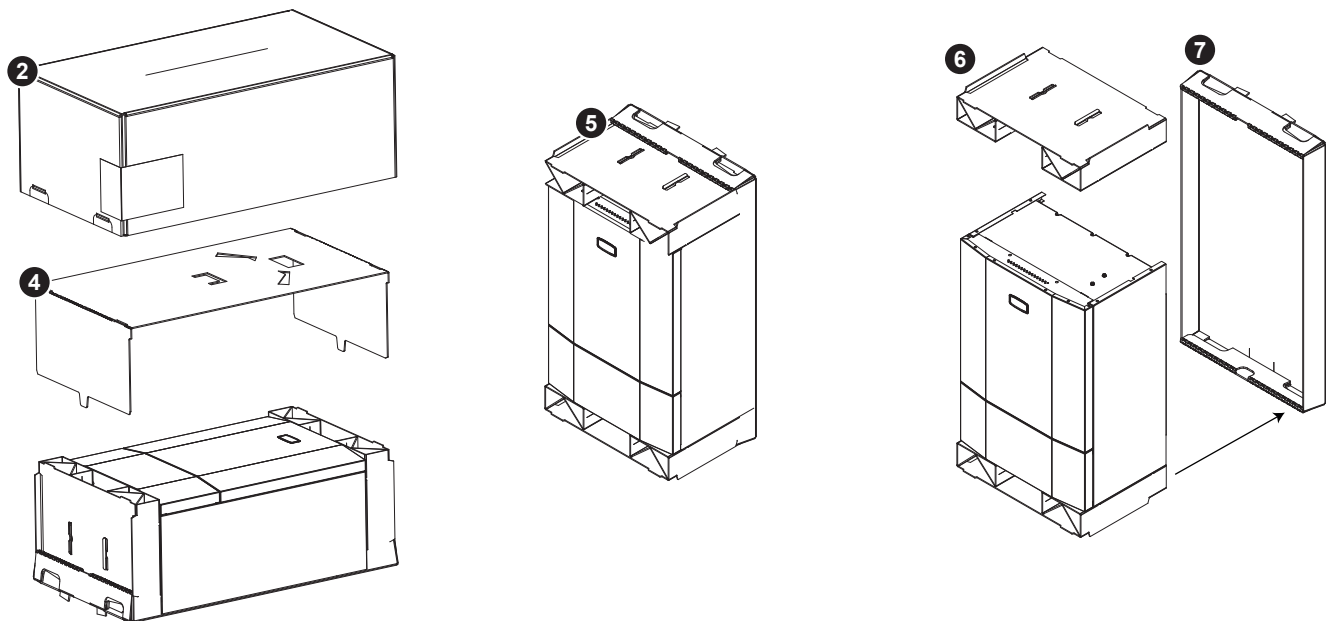

SECTION 2 - INSTALLATION

2.3 MOUNTING THE HEAT INTERFACE UNIT

1. Ensure the plastic plugs are removed from both the Primary and DHW connections before mounting the HIU.

Note: HIU may contain residual water.

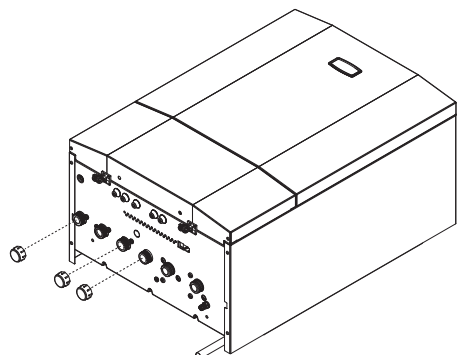

2. Indirect only

- a. Isolate the incoming cold water mains prior to the HIU.
- b. Ensure isolation valves are in the closed position (handles horizontal).
- c. Remove brass plugs from the top of the isolation valves (if used). Discard any used gaskets.

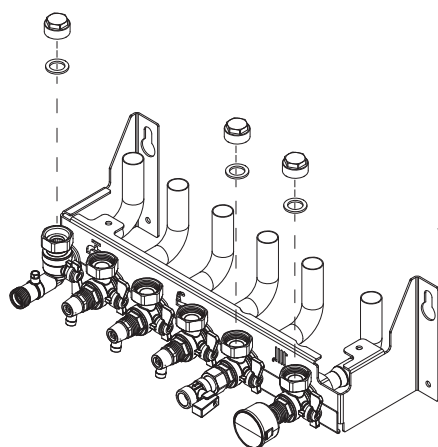

4. Lift the HIU onto the wall mounting plate (refer to the Introduction section for safe handling advice), locating it over the two tabs. The HIU unit will need to be lifted clear of lower bracket connections to sit flush.

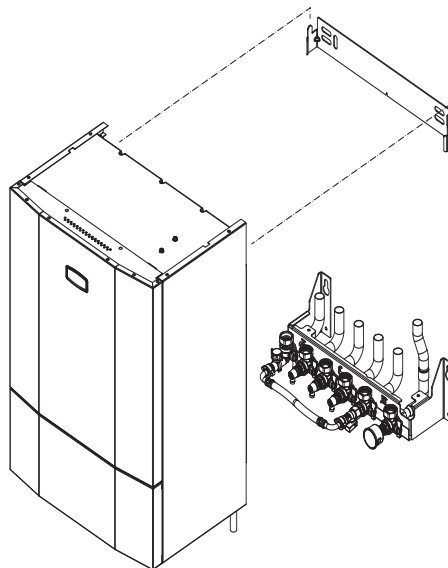

5. Install 2 x HIU securing screws from underneath of bracket.

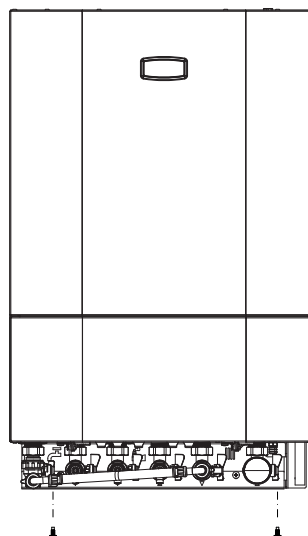

2.4 CONNECTIONS

With the appliance in place, insert a G3/4 fibre gasket between the top of each isolation valve and the appliance connection. Tighten each nut to 16.6Nm.

NOTES.

Ensure all connection blanking plugs are removed before connecting hardware. Each valve must be fitted to the correct connection as shown in the picture.

Ensure each union is fitted with fibre seals provided.

Do not subject any of the isolating valves to heat other than normal operation as the seals may be damaged.

Flow Regulator Flow Rate / Colour Housing / Colour Core	Flow Tolerance			Power Rating kW
	Deviations		Pressure Range (bar)	
	+10%	-10%		
12.3 l/min / natural / orange	10	10	1 - 10	30
16.4 l/min / natural / green	10	10	1 - 10	40
20.5 l/min / natural / yellow	10	10	1 - 10	50
27.0 l/min / natural / natural	10	10	1.5 - 10	60
28.7 l/min / natural / dark grey	10	10	1.5 - 10	70

Continued....

SECTION 2 - INSTALLATION

PRESSURE RELIEF VALVE (INDIRECT ONLY)

The safety valve connection, located at the bottom right-hand side of the HIU, comprises a 15mm diameter stub pipe.

The installer must provide a suitable joint on the end of the stub pipe. This assists with pipe removal when servicing.

The discharge pipe must be positioned so that the discharge of water or steam cannot create a hazard to the occupants of the premises or damage the electrical components and wiring.

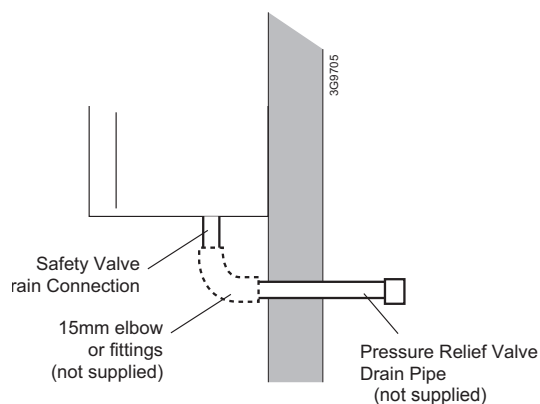

2.5 SYSTEM FILLING

Note: Isolation valves are labelled A to F from left to right. 4. Connect the filling loop to valve A.

Filling DHW

1. Ensure all taps in the property are turned off.
2. Turn the blue valve handle on isolation valve A to the "run" position (handle pointing downward).
3. Turn on the incoming mains water supply.
4. With a suitable hose and container fitted to the upper far left air vent, open upper DHW vent screw to allow air to exit. As soon as air free water flow is detected close the vent.
5. Turn isolation valve B to the "run" position (handle pointing upwards).
6. Open the furthest tap from the unit to vent any air from the system.

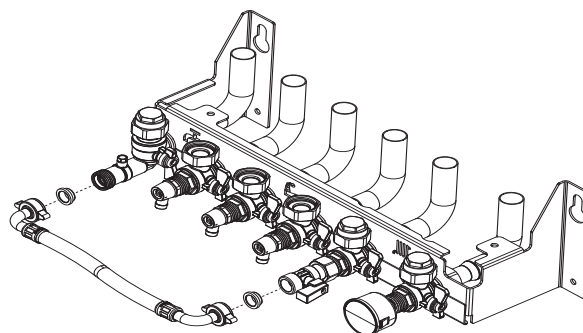

Note: Heat Interface Unit not shown for clarity

Filling CH / Topping up (Indirect Only)

1. Ensure isolation valves A, E and F are in the "run" position (handle vertical) and isolation valve G is in the "off" position (handle opposing body).

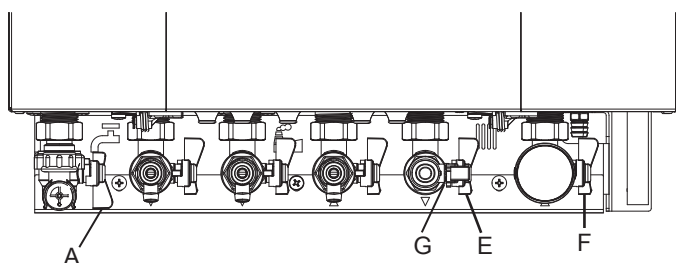

2. Remove the dust cap from valve A and plug from the filling loop adjacent to valve A.
3. Ensure top hat washers is still fitted to the valve A (if not then check inside the removed dust cap).

Filling Loop Hose

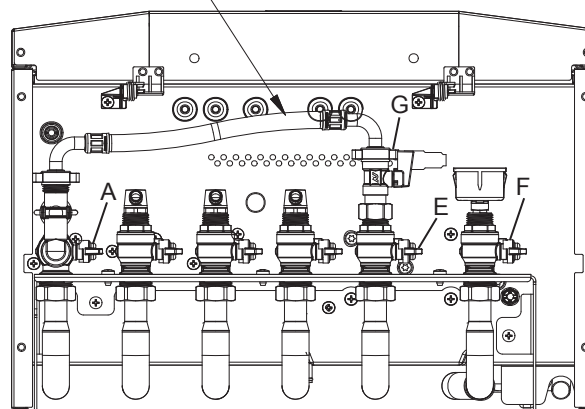

5. Turn isolation valve A to the "fill" position (handle horizontal).
6. Turn valve G to the "fill" position (handle in line with valve body). The CH circuit will begin to fill.
7. Monitor the pressure gauge until the correct pressure is achieved (max 2.75 Bar, recommended 1 – 1.5 bar for normal operation) then turn isolation valve G to the "off" position (handle opposing valve body) to isolate the charge supply.

Continued...

SECTION 2 - INSTALLATION



Note: If refilling the unit or system rather than topping up, air may require manual venting from the CH circuit by a certified agent. Refer to the installation and servicing instructions for more information.

8. Turn isolation valve A to the "run" position (handle vertical).
9. Remove the filling loop hose from valve A. Insert storage plug into left side of filling loop hose.
Note: A small volume of water may remain within the hose.
10. Ensure top hat washer is still attached to isolation valve A.
11. Screw the dust cap to the front of isolation valve A.

PRIMARY CONNECTIONS

Filling Primary Circuit (Indirect)

1. Remove the front cover (Section 3.4) and the insulation (Section 3.12) to gain access to the Primary return air vent.
2. Turn the black handle on isolation valve D so it is pointing upward, the water will now flow from the primary circuit into the primary PHE circuits on both PHE.
3. With a suitable hose and container fitted to the Primary Air Vent (front of tee), open vent screw to allow air to exit. As soon as air free water flow is detected close the vent.
Note: The water in the primary circuit will be hot so caution must be taken to prevent splashes when venting.
4. Open Primary return isolation valve C by rotating handle upward.
5. Turn on electrical supply to the HIU.
6. The 2 PICV on the primary circuit will open and close whilst they carry out an initial calibration cycle, this will allow additional water to be released into the PHEs.
7. Repeat items 2 to 4 to bleed remaining air.

Note: If the unit has not been initially powered up, then valves C and D should be moved to the close position to prevent primary flow. After the initial power up the PICVs will have carried out their calibration and be in the closed position.

Filling Primary Circuit (Direct)

1. Remove front cover (section 3.4) and the insulation (section 3.12) to gain access to the Primary and CH Air Vents.
2. Ensure isolation valves C, D, E and F are in closed position (handle horizontal).
3. Turn the black handle on isolation valve D so it is pointing upwards, the water will now flow from the primary circuit into the primary PHE circuit and the CH flow pipe.
4. With a suitable hose and container fitted to the Primary and CH air vents, open vent screw and allow air the exit. As soon as air free water flow is detected close the vent.

Note: The water in the primary circuit will be hot so caution must be taken to prevent splashes when venting.

5. Open the Primary return valve C, CH flow valve E and CH return valve F by rotating the handle into the vertical position. This will cause the CH circuit external to the appliance to be filled and pressurised. Additional venting and commissioning should be undertaken as required by the system designer.
6. Turn on the electrical supply to the HIU.
7. The 2 PICV's on the primary circuit will open and close whilst they carry out an initial calibration cycle, this will allow additional water to be released into the PHE's.
8. Repeat items 3 - 5 to bleed remaining air.

Note: If the unit has not been initially powered up, then valves C and D should be moved to the close position to prevent primary flow. After the initial power up the PICVs will have carried out their calibration and be in the closed position.

Initial commissioning

1. Ensure all isolation valves are in the "run" position.
2. Locate the 2 x pressure test points (primary flow Red & primary return Blue) positioned on the primary flow and primary return manifolds. Unscrew the caps as required.
3. Connect a suitable high-water pressure measuring device to the appropriate pressure connections.
4. Set the instrument up to measure differential pressure and the units kPa.
5. Activate a kitchen or bath tap and ensure the pressure differential reading is no lower than 50 kPa.
6. Ensure that the DHW flow temperature is stable.
7. Turn off the outlet after checking.
8. If necessary to improve stability of the DHW temperature, unscrew the DHW actuator from the PICV body.
9. Release the brass locking ring on the valve stem and adjust the valve limit according to the table below. Tighten down the locking ring.
10. Replace the DHW actuator.
Note: If the actuator does not travel the majority of the valve body's actuator mounting thread, turn the mains on and activate a DHW delivery. This will open the valve and allow the actuator mounting collar to be tighten fully on to the valve. The unit must be then turned off at the mains and back on to allow the valve to recalibrate its position.
11. Recheck the DHW flow temperature. The DHW flow temperature should be achieved quickly with minimal overshoot above the target temperature and should settle quickly to a stable flow temperature.
12. If necessary, repeat the adjustment. Increase the setting if the target flow temperature is not achieved, decrease the setting if the flow temperature is not stable. After each adjustment the unit must be then turned off at the mains and back on to allow the valve to recalibrate its position.
13. Activate the central heating and take the primary differential pressure reading. Ensure the reading lies within manufactures requirements.

Note: Primary pressure drops below the nominal 50kpa will slightly reduce the output of the product.

Continued...

SECTION 2 - INSTALLATION

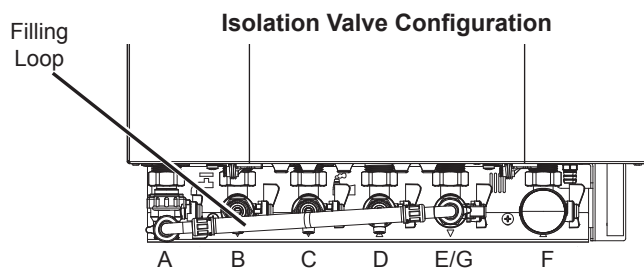

Note: Tap 'E' is the main CH connection tap. Tap 'F' is the filling loop tap.

DHW Capacity	Factory PICV Setting	Adjusted PICV Setting
30kW (POD i305 / D30)	4.0	1.5
40kW (POD i405 / D40)	4.0	1.9
50kW (POD i505 / D50)	4.0	2.5
60kW (POD i605 / D60)	4.0	2.9
70kW (POD i705 / D70)	4.0	3.5

2.6 DIRECT PICV SETTING

The POD direct heating systems have on/off functionality only, fixed flow rate control and no temperature control.

If the resistance of the central heating system is low, the flow rate can be reduced further than the pre-set position with the following steps:

1. Remove the actuator from the Central Heating PICV.
2. Rotate the small brass locking ring on the top of the valve spindle anti-clockwise to unlock.
3. Rotate the white spindle cover clockwise, aligning the line on the white spindle cover with the relevant numbers on the valve body (1 low flow high inlet restriction and 4 high flow low inlet restriction).
4. Tighten the brass locking ring.
5. Refit actuator ensuring it is fully fitted to the body with one or fewer threads visible.

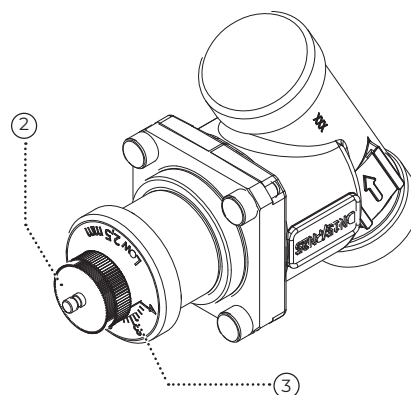

The graph shows the central heating flow rate reduction with a primary run at 50 kPa and 70°C when manually adjusting the valve inlet throttle.

If the flow rate is too low for the central heating system's resistance, it may have difficulty transferring heat to the more remote radiators on the heating system.

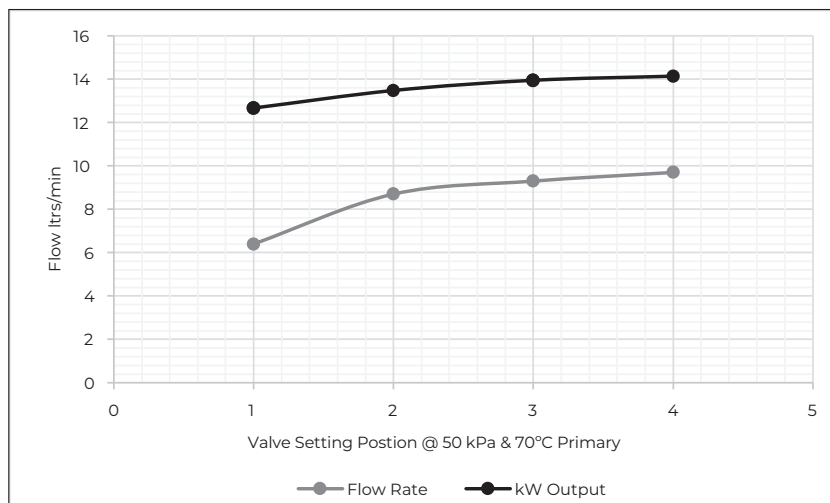

2.7 ELECTRICAL CONNECTIONS

WARNING. This appliance MUST be earthed.

All electrical work within the unit should be carried out by a competent person and be compliant with BS 7671.

A mains supply of 230Vac ~ 50Hz is required. The appliance must be protected by a 3A fuse.

Wiring should be 3 core PVC insulated cable, not less than 0.75mm² (24 x 0.2mm) and to BS 6500 Table 16.

For IE reference should be made to the current ETCI rules for electrical installations.

Connection must be made in such a way that allows complete isolation of the electrical supply such as a double pole switch having 3mm contact separation in both poles.

The means of isolation must be accessible to the user after installation.

SECTION 2 - INSTALLATION

2.8 INSTALLER WIRING

The image below shows the HIU electrical connections.

The HIU must be connected to a permanent live supply via the 'L' 'N' and 'GND' connections and not switched by thermostats/programmers. The installer wiring must be inserted through the rubber grommets in the base of the HIU and securely clamped by the cable retention bars to prevent strain on the terminal block connections.

Accessing the installer wiring

1. Isolate the mains supply from the HIU.
2. Open the drop-down cover and remove the front access panel. Refer to Section 3.4.
3. Gently swing down the control box into the service position to expose the installer connections.

All the installer connections can now be easily accessed. Once any wiring is complete, to ensure the HIU is safe, rebuild the unit in the reverse order above.

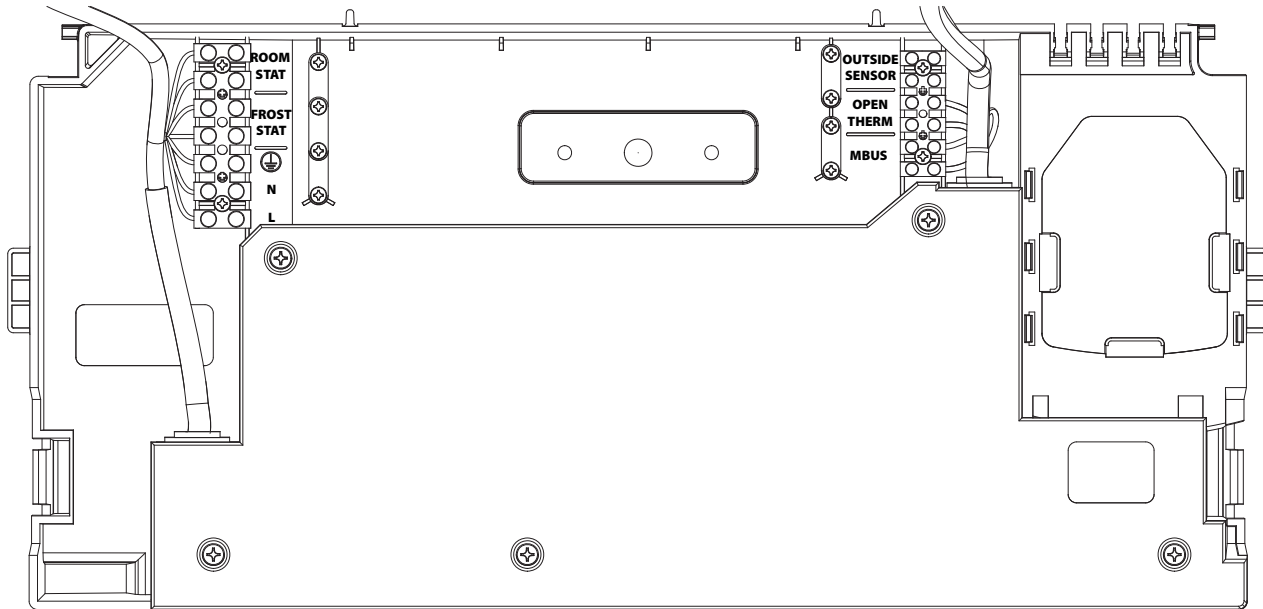

2.9 EXTERNAL WIRING

External Controls – 230V 50Hz

Wiring a 230Vac 50Hz Room thermostat, Diagram A (with optional timer, Diagram B)

1. Connect the external cable from the room thermostat/timer across the terminal labelled 'Room Stat'. See Diagram A.
2. If the room thermostat has compensation and requires a neutral connection, make this connection to the fused spur on the load side. See Diagram C.

Optional External Controls – Extra Low Voltage

Wiring OpenTherm Room Control or other OpenTherm Master Device, Diagram D.

1. Connect the two OpenTherm cables from the external OpenTherm controller into the terminals labelled 'OpenTherm'. See Diagram D.
2. Ensure no other controllers are connected to the High Voltage 'Room Stat' connection as this will prevent the HIU/OT+ communication functioning correctly.

Frost Protection

If parts of the pipework run in areas subject to cold temperatures or if the HIU will be left in the 'Off' state for more than a 1-day period a frost thermostat should be wired into the system. The frost thermostat should be sited at coldest point in a system such that it can sense heat from the system.

Wire a system frost thermostat to the terminals labelled 'Frost Stat' as detailed in diagrams A, B and C.

DIAGRAM A:

Programmable Room Stat or Room Stat with Internal Timer

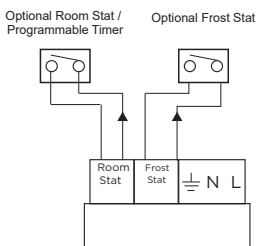

DIAGRAM B:

Room Stat with External Timer

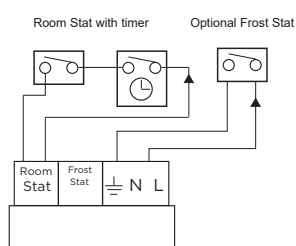

DIAGRAM C:

Use of General Live for Room Stat

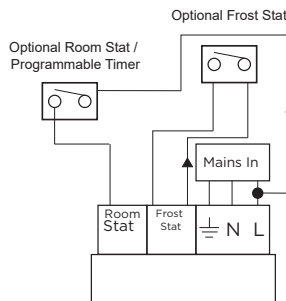
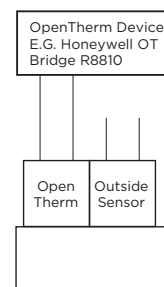

DIAGRAM D:

OpenTherm Device

DO NOT CONNECT 230V TO THESE TERMINALS OR THE HIU ELECTRONICS WILL BE DAMAGED



SECTION 2 - INSTALLATION

2.11 EXTERNAL WIRING

Electrical Installation

1. Checks to ensure electrical safety should be carried out by a competent person.
2. ALWAYS carry out the preliminary electrical system checks, i.e. earth continuity, polarity, resistance to earth and short circuit, using a suitable test meter.

ATTENTION !
IT IS A CONDITION OF THE MANUFACTURER'S WARRANTY THAT THE COMMISSIONING CHECKLIST IS FULLY COMPLETED AND LEFT WITH THE APPLIANCE

2.12 INITIAL OPERATION & POWER UP

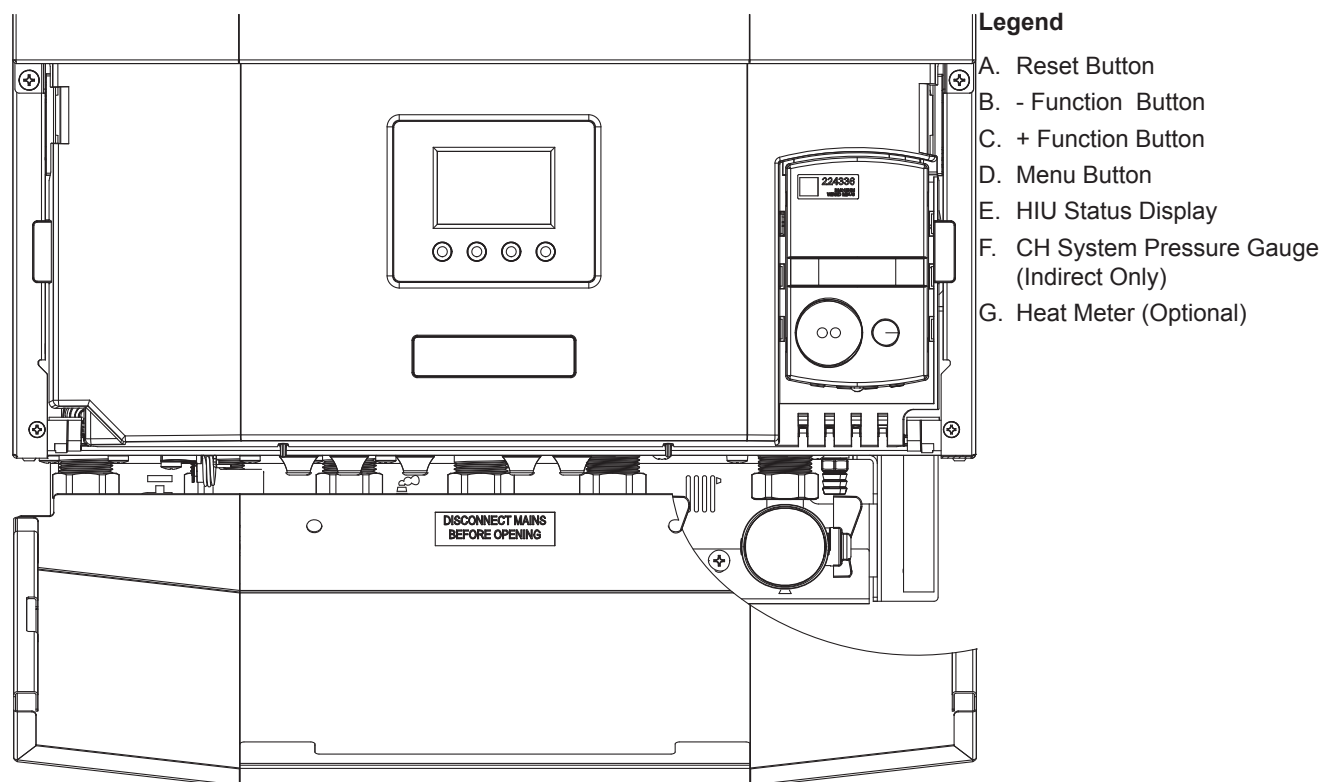

After initial power-up of the HIU the controls will initialise and display information about unit type and power output. The first screen will show the HIU type as 'II' (Indirect/Indirect), or 'dl' (direct/Indirect). The second screen will show the DHW output (30kW, 40kW, 50kW, 60kW or 70kW). The HIU controls can now be used to electronically open / close the primary control valves to allow for commissioning and balancing of the primary network and the commissioning engineer can input all the relevant parameters to provide efficient operation of the HIU and the Heat Network.

2.13 DISPLAY FUNCTIONS

2.13.1 MENU NAVIGATION

The user control has a Symbolic LCD which provides information to the user about the status of the HIU. The temperatures shown as follows are for illustration purposes only. The actual set point or measured temperatures will be shown on the HIU.

Notes: HIU frost protection – HIU operates if temperature is below 5°C.

HIU Mode Off

In the 'Off mode' the HIU will only provide Frost protection via the external frost stat and internal thermistor monitoring.

To switch DHW, CH and Hot Water Preheat on or off press the Menu button (D on controls diagram) to cycle through the user settable parameters.

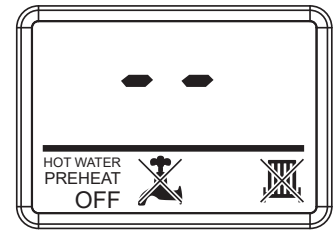

Changing DHW Temperature

From normal operation screen press the Menu button to access the DHW target temperature setting menu. The DHW target temperature can now be adjusted by pressing the +/- buttons within the installer defined limits (Refer to Section 2.12.3 for Direct Units).

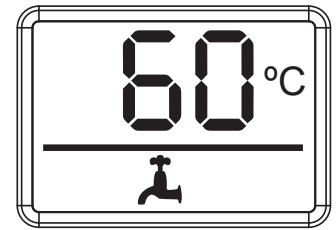

Changing CH Temperature

Press the Menu button again to access the CH target temperature setting menu.

The CH target temperature can now be adjusted by pressing the +/- buttons within the installer defined limits.

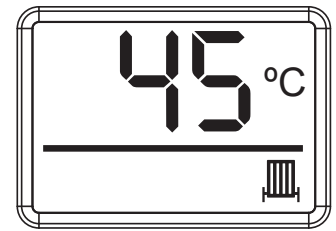

Note: If using underfloor heating ensure CH target temperature is within the safe operating temperature for the underfloor heating.

Switching CH On/Off

Press the Menu button again to access the CH state setting menu.

Press the +/- buttons to either enable or disable the CH operation.

Press the Menu button again to access the DHW state setting menu.

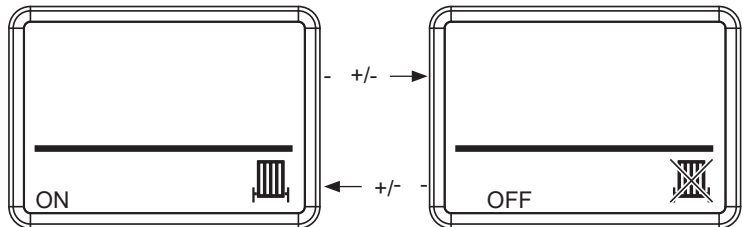

Switching DHW On/Off

Press the Menu button again to access the DHW state setting menu.

Press the +/- buttons to either enable or disable the DHW operation.

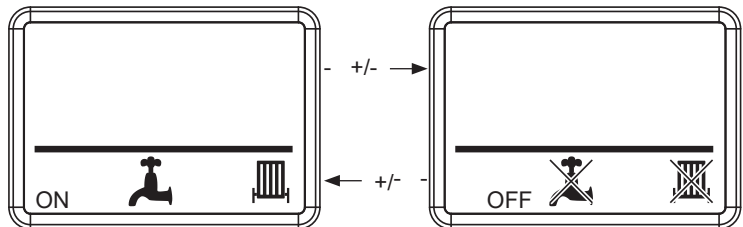

Switching Preheat On/Off

Press the Menu button again to access the Preheat state setting menu.

Press the +/- buttons to either enable or disable the Preheat operation.

Press the Menu button again to return to normal operation.

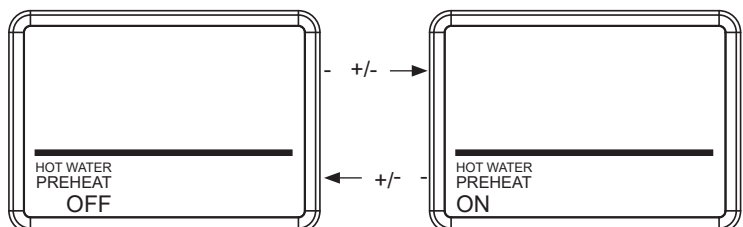

SECTION 2 - INSTALLATION

DISPLAY FUNCTIONS - CONT'D

2.13.2 NORMAL OPERATION

In normal operation with DHW and CH enabled and Preheat disabled the display will show:

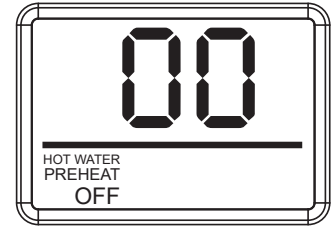

With a DHW demand the display will show the tap symbol and the DHW delivery temperature:

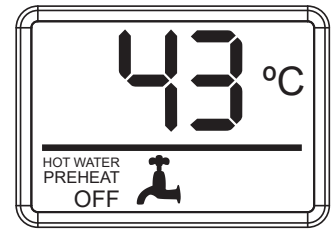

With a CH demand the display will show the radiator symbol and the CH delivery temperature:

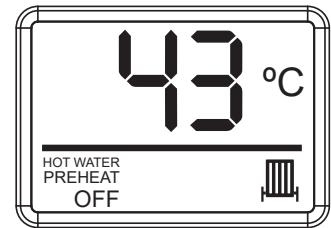

If Preheat is enabled the HIU will open the DHW valve to Preheat the DHW plate. While the valve is open the display will show the tap symbol and alternate between showing the plate temperature and the letters 'PH'.

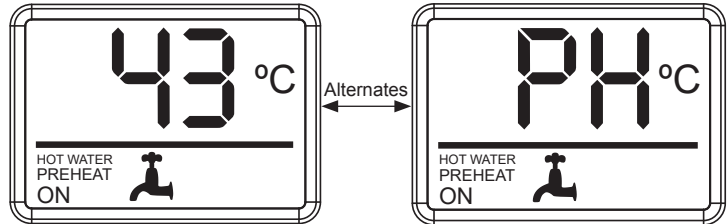

If the HIU received a frost protection demand the display will alternate between the CH temperature and the letters 'FP'.

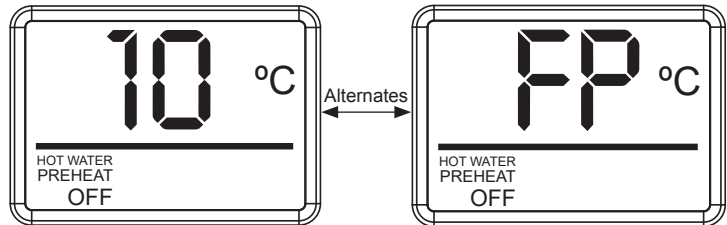

SECTION 2 - INSTALLATION

DISPLAY FUNCTIONS - CONT'D

2.13.3 SET CH TEMPERATURE 45°C - 80°C

The maximum flow temperature is defaulted to 45°C (Indirect Units) and 80°C (Direct Units), this can be adjusted and limited, up to a maximum of 80°C by following the procedure below:

Turn off the power to the HIU, turn the power back on, then press and hold the Reset and the Menu buttons together for 5 seconds until 'uP' is shown:

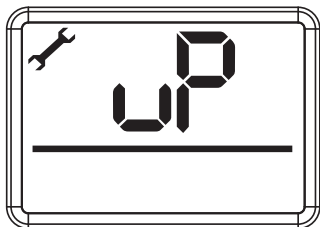

The screen will show the HIU type (e.g. II, dI) corresponding to the chosen parameter set.

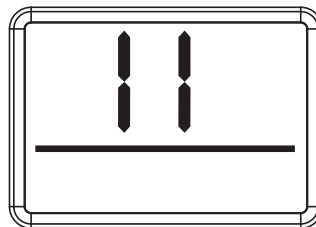

Press the reset button within five minutes, 'oF' is shown.

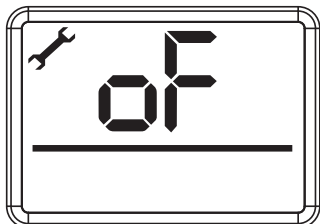

Press Menu again to show the DHW Output capacity.

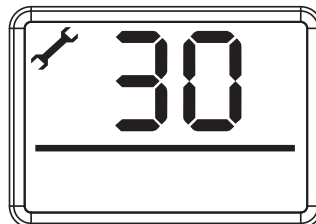

Power off and on the PCB, the screen will show 'F9'.

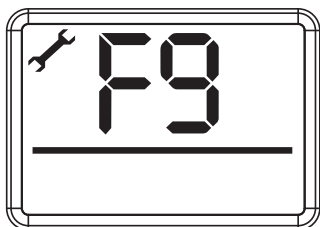

Press the Menu button again.

Press the -/+ buttons to adjust the maximum DHW temperature.

Range: 35°C – 65°C

Press the Menu button when the required limit is selected.

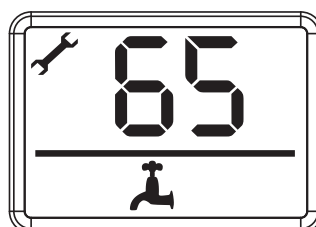

Press the -/+ buttons to cycle through the available parameter sets.

Please refer to table overleaf for the HIU model number and corresponding parameter set number.

Press the Menu button when the correct option is selected.

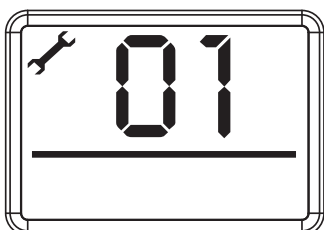

Press the -/+ buttons to adjust the maximum CH flow temperature.

Range: 45°C – 80°C

Note: For Direct Units, this becomes the CH flow setpoint. This should generally be set a few degrees higher than the primary circulation temperature to prevent the appliance from closing off flow before the room thermostat or heating controller is satisfied.

Press the Menu button when the required limit is selected to resume normal operation.

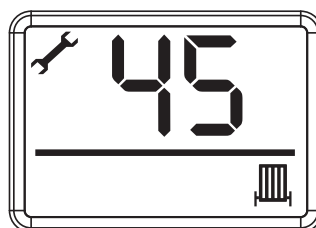

SECTION 2 - INSTALLATION

DISPLAY FUNCTIONS - CONT'D

Parameter Set Table

Parameter Set Number	Type	Max DHW Output (kW)	CH Heat Exchanger (kW)	Model Number
1	Indirect	30	5	i305
2	Indirect	40	5	i405
3	Indirect	50	5	i505
4	Indirect	60	5	i605
5	Indirect	70	5	i705
6*	Indirect	30	15	i315
7*	Indirect	40	15	i415
8*	Indirect	50	15	i515
9*	Indirect	60	15	i615
10*	Indirect	70	15	i715
11	Direct	30	n/a	d30
12	Direct	40	n/a	d40
13	Direct	50	n/a	d50
14	Direct	60	n/a	d60

Models marked * to be confirmed. Parameter sets are not to be used.

DISPLAY FUNCTIONS - CONT'D

2.13.4 SERVICE MODES

Navigate the Standard menu as displayed on page 26 using the 'Menu' button until the 'Preheat Enable' screen is displayed.

Then press + and - buttons together for 3 seconds to enter service mode.

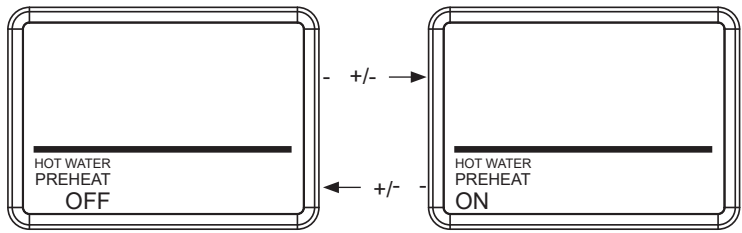

The display will begin to cycle through the last 3 faults.

(example fault only)

Press the Menu button to progress to the 'Pump Modulation Setting' display:



Press +/- to set the pump modulation to either P7 (70% modulation enabled) and P1 (modulation disabled).

Press the Menu button to progress to the 'Valve Calibration' service mode.

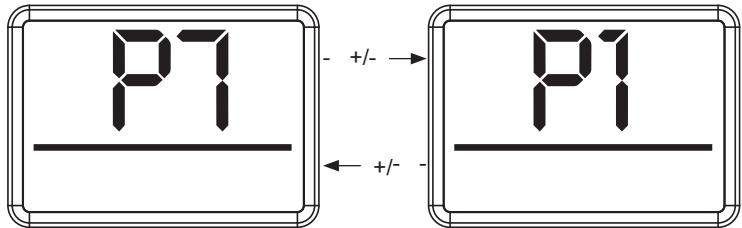

Press +/- to calibrate both DHW & CH valves.

Press the Menu button to progress to the 'DHW Valve Replacement' service mode:

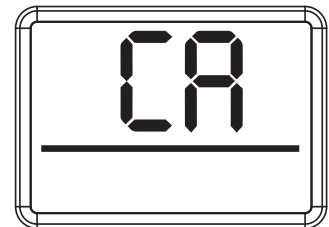

If +/- buttons are pressed the DHW valve will drive fully open for up to 30 minutes. This may be required if the valve body needs to be replaced.

WARNING: if primary supply is not isolated this service mode will charge the DHW heat exchanger which could cause a scold risk.

Press the Menu button again to progress to the 'CH Valve Replacement' service mode:

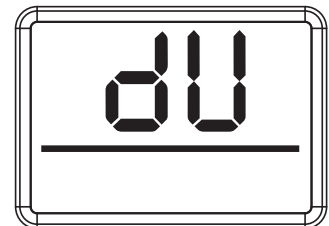

If +/- buttons are pressed the CH valve will drive fully open for up to 30 minutes. This may be required if the valve body needs to be replaced.

WARNING: If the primary supply is not isolated this could result in a hot slug of water building up in the CH heat exchange which could cause damage to certain heating systems when the pump is activated.

Press the Menu button again to progress to the 'CH Maximum Rate' service mode:

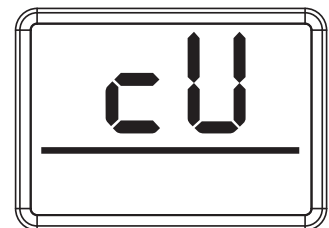

SECTION 2 - INSTALLATION

SERVICE MODES - CONT'D

If +/- buttons are pressed the Central Heating will run at maximum rate for up to 30 minutes

Press the Menu button again to progress to the 'Slab Setting' service mode:

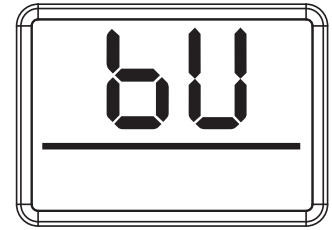

If +/- buttons are pressed the CH Slab setting function will be activated. This function will increase the CH flow temperature from 15° C by 1° C every 24 hours until the slab temperature exceeds 45°c or the target CH temperature of this function is cancelled by pressing the Menu button. Press the Menu button again to progress to the 'Primary Return Limit' activation display:

Press +/- buttons to enable / disable the primary return limitation function.

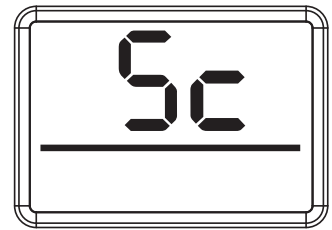

This function allows the return temperature of the primary system to be limited for more efficient system

Press the Menu button again to progress to the 'Credit Control' setting display:

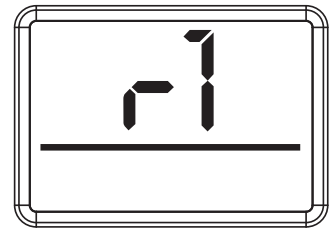
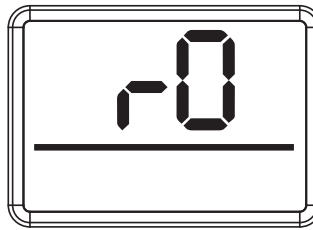

Note: This function is independent of the Credit control valve accessory behaviour.

Press the Menu button again to return to normal operation.

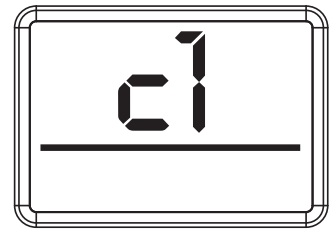
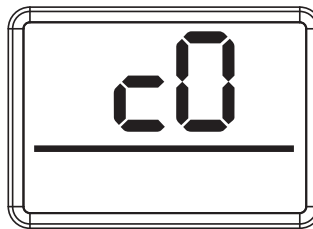

SECTION 2 - INSTALLATION

2.14 RESET PROCEDURE

To Reset the HIU, press the RESET button (A).

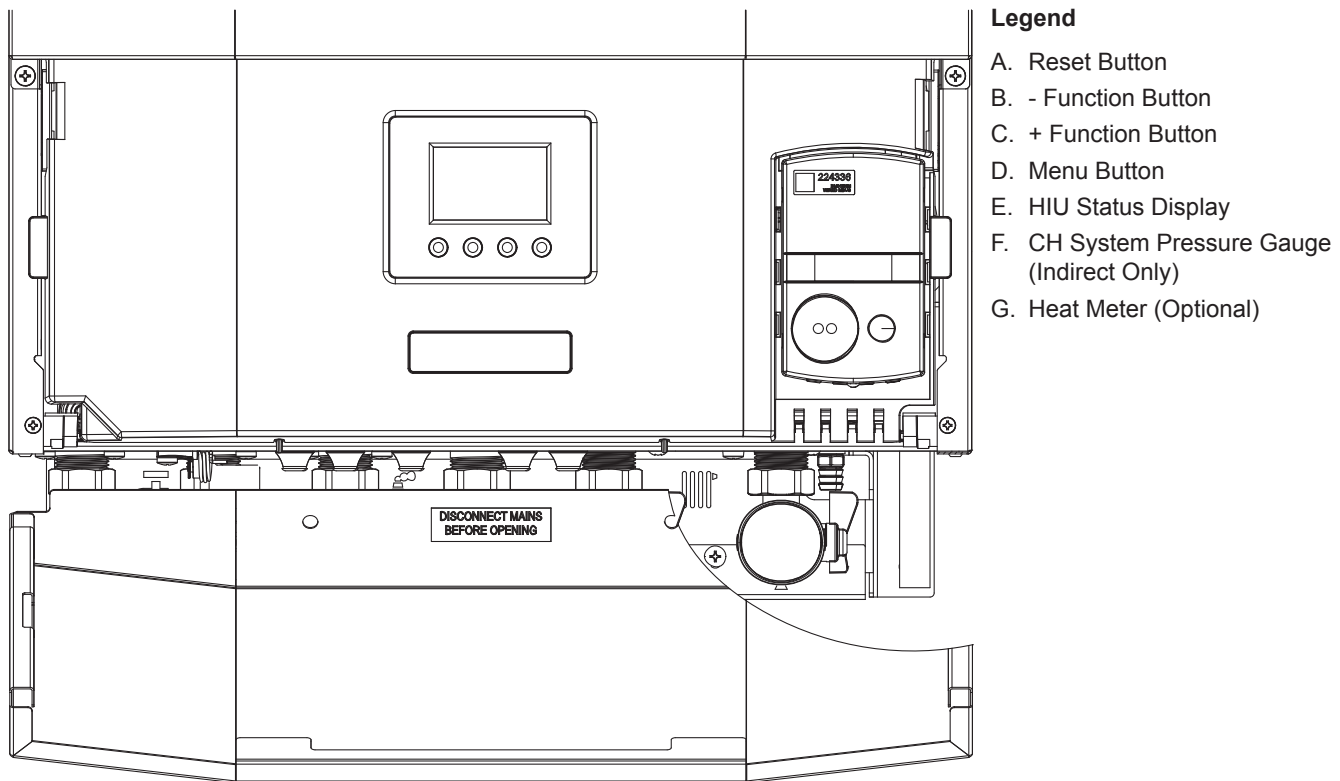

2.15 HANDING OVER

After completing the installation and commissioning of the system the installer should hand over to the householder by the following actions:

1. Hand the User Instructions to the householder and explain his/her responsibilities under the relevant national regulations.
2. Explain and demonstrate the start-up and shutting down procedures.
3. The operation of the HIU and the use and adjustment of all system controls should be fully explained to the householder, to ensure the greatest possible economic use is consistent with the heat network requirements of both heating and hot water consumption.
Advise the User of the precautions necessary to prevent damage to the system and to the building, in the event of the system remaining inoperative during frosty conditions.
4. Explain the function and the use of the HIU heating and domestic hot water controls.
Explain that due to system variations and seasonal temperature fluctuations DHW flow rates/temperature rise will vary, requiring adjustment at the draw off tap. It is therefore necessary to draw the user's attention to the section in the Users Instructions titled "Control of Water Temperature" and the following statement:
"Additionally, the temperature can be controlled by the user via the draw-off tap: the lower the rate the higher the temperature, and vice versa".
5. Explain the function of the HIU fault mode.
6. Explain and demonstrate the function of timers and temperature controls, radiator valves etc., for the economic use of the system.
7. If a timer is fitted draw attention to the timer's User Instructions and hand them to the householder.
8. Loss of system water pressure.
Explain that the dial on the pressure gauge under the unit indicates the central heating system pressure and that if the normal COLD pressure of the system is seen to decrease over a period of time then a water leak is indicated. Explain the re-pressurising procedure and if unable to re-pressurise, or if the pressure continues to drop, a registered local heating installer should be consulted. Refer to Section 2.4.
9. Explain the HIU reset procedure. Refer to Section 2.13.
10. After installation and commissioning please complete the Commissioning Checklist before handover to the customer.
IMPORTANT
11. A comprehensive service should be carried out ANNUALLY. Stress the importance of regular servicing by a qualified heating engineer.
12. Inform the householder of the guarantee/registration found within the envelope pack and the requirement to register it to receive the full benefit of the warranty.

3. SERVICING

3.1 SERVICING SCHEDULE

For the very latest copy of literature for specification & maintenance practices, visit our website idealheating.com, where you will be able to download the relevant information.

To ensure the continued safe and efficient operation of the appliance it is recommended that it is checked at regular intervals and serviced as necessary. The frequency of servicing will depend upon the installation condition and usage but should be carried out at least annually.

Note: In order to carry out either servicing or replacement of components the HIU front panel and insulation must be removed. Refer to Sections 3.4 & 3.12.

1. Check the HIU for any signs of water leakage. If required isolate and drain down then re-make any joint as necessary and ensure the system is correctly re-filled, vented and re-pressurised.
2. Check CH circuit pressure and top up if necessary.
3. Check operation of CH by calling for a heating demand. Note any operational faults and refer to Section 4 fault finding as necessary.
4. Check the operation of the DHW by opening the largest draw off. Note any operational faults and refer to Section 4 fault finding as necessary.

Warning: Always isolate all service valves, switch off and disconnect the electrical supply to the appliance before servicing.

5. Check the DHW filter for blockage and clean out any material present (refer to Section 3.21).
6. Check the primary circuit strainer (refer to Section 3.6).
7. Check the primary circuit Δp as follows:
 - a. Unscrew caps on the pressure test points on the primary flow and return manifolds.
 - b. Connect a suitable high-water pressure measuring device to the appropriate pressure connections.
 - c. Set the instrument to measure differential pressure and set the units to kPa.
 - d. Open the largest DHW draw off and ensure the differential pressure is minimum 50kPa.
 - e. Turn the tap off and call for a heating demand and ensure the differential pressure is minimum 50kPa.

Note: Primary differential pressure below the nominal 50kPa will slightly reduce the output of this product.

IMPORTANT

1. After completing the servicing or exchange of components always ensure all hydraulic connections are watertight and ensure all harness connections are connected as found.
2. When work is complete the front panel MUST be correctly refitted.
3. Clean the Ideal System Filter (if fitted). Refer to system filter installation & maintenance guide for correct method of servicing.
4. Complete the service section in the Commissioning Checklist.

SECTION 3 - SERVICING

3.2 KEY COMPONENTS - INDIRECT

- | | | | |
|------------------------------------|-------------------------------------|-------------------------------|----------------------------------|
| 1. PHEX Assembly DHW | 8. Manifold Primary Return Assembly | 15. Air Vent CH | 23. Thermistor DHW |
| 2. PHEX Assembly CH | 9. Manifold DHW Flow Assembly | 16. PRV | 24. Mini Expansion vessel |
| 3. Expansion Vessel | 10. Manifold DCW Assembly | 17. Auto Air Vent | 25. Drain Point DCW |
| 4. Thermistor 18mm CH Return | 11. PICV DN20 | 18. Pump Head | 26. Flow Turbine Sensor and Clip |
| 5. Thermistor 18mm CH Primary Flow | 12. PICV DN15 | 19. Pressure Switch | |
| 6. Waterset CH | 13. Air Vent DCW | 20. Pressure Test Point | |
| 7. Manifold Primary Flow Assembly | 14. Air Vent Primary | 21. Primary Return Thermistor | |
| | | 22. Pressure Test Point | |

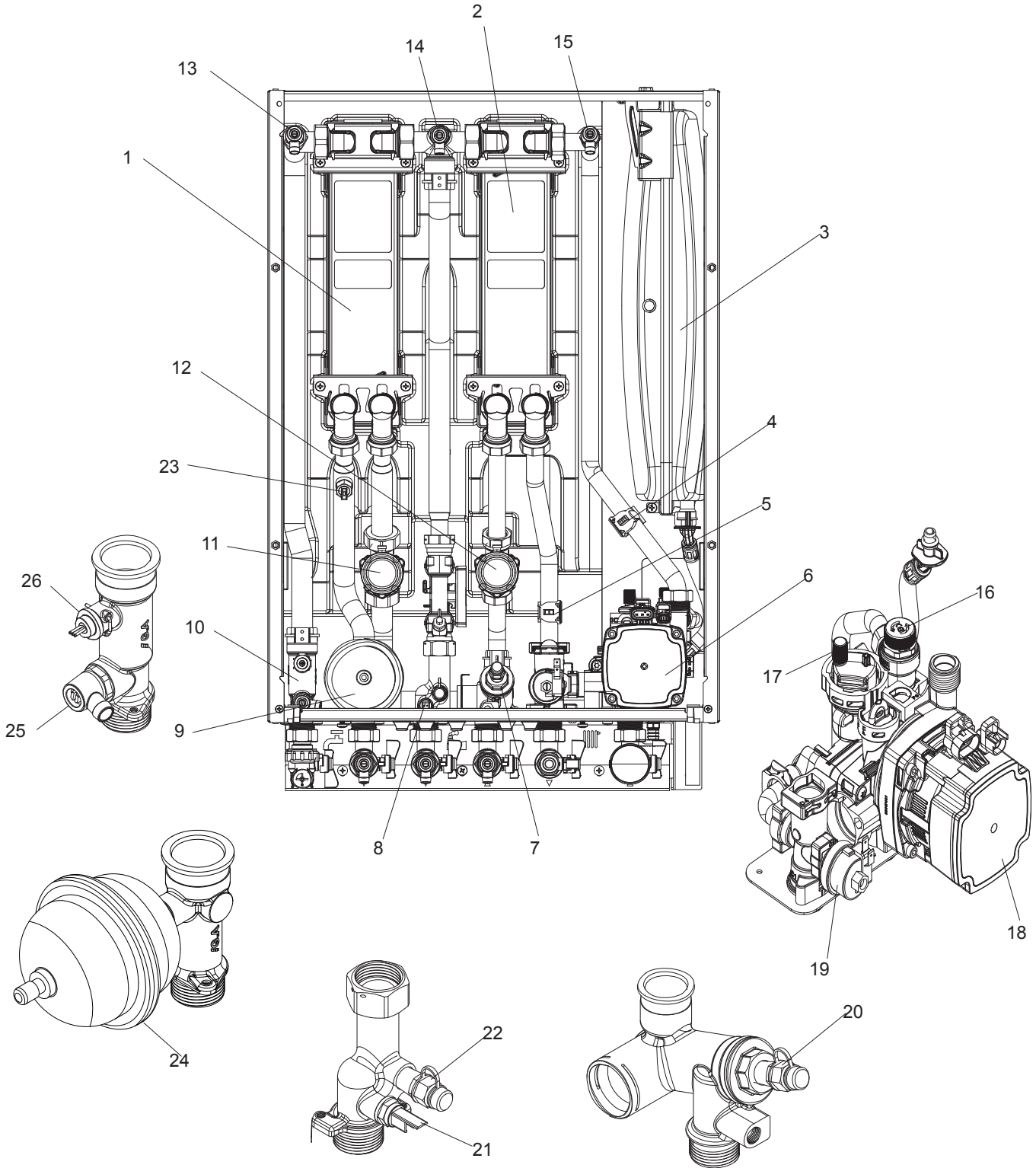

SECTION 3 - SERVICING

3.3 KEY COMPONENTS - DIRECT

Note: Greyed out parts listed on this key are not applicable to the Direct HIU model.

- | | | | |
|--|--|---|---|
| <ul style="list-style-type: none"> 1. PHEX Assembly DHW 2. PHEX Assembly CH 3. Expansion Vessel 4. Thermistor 18mm CH Return 5. Thermistor 18mm CH Primary Flow | <ul style="list-style-type: none"> 6. Wasset CH 7. Manifold Primary Flow Assembly 8. Manifold Primary Return Assembly 9. Manifold DHW Flow Assembly 10. Manifold DCW Assembly 11. PICV DN20 12. PICV DN15 | <ul style="list-style-type: none"> 13. Air Vent DCW 14. Air Vent Primary 15. Air Vent CH 16. PRV 17. Auto Air Vent 18. Pump Head 19. Pressure Switch 20. Pressure Test Point 21. Primary Return Thermistor | <ul style="list-style-type: none"> 22. Pressure Test Point 23. Thermistor DHW 24. Mini Expansion vessel 25. Drain Point DCW 26. Flow Turbine Sensor and Clip |
|--|--|---|---|

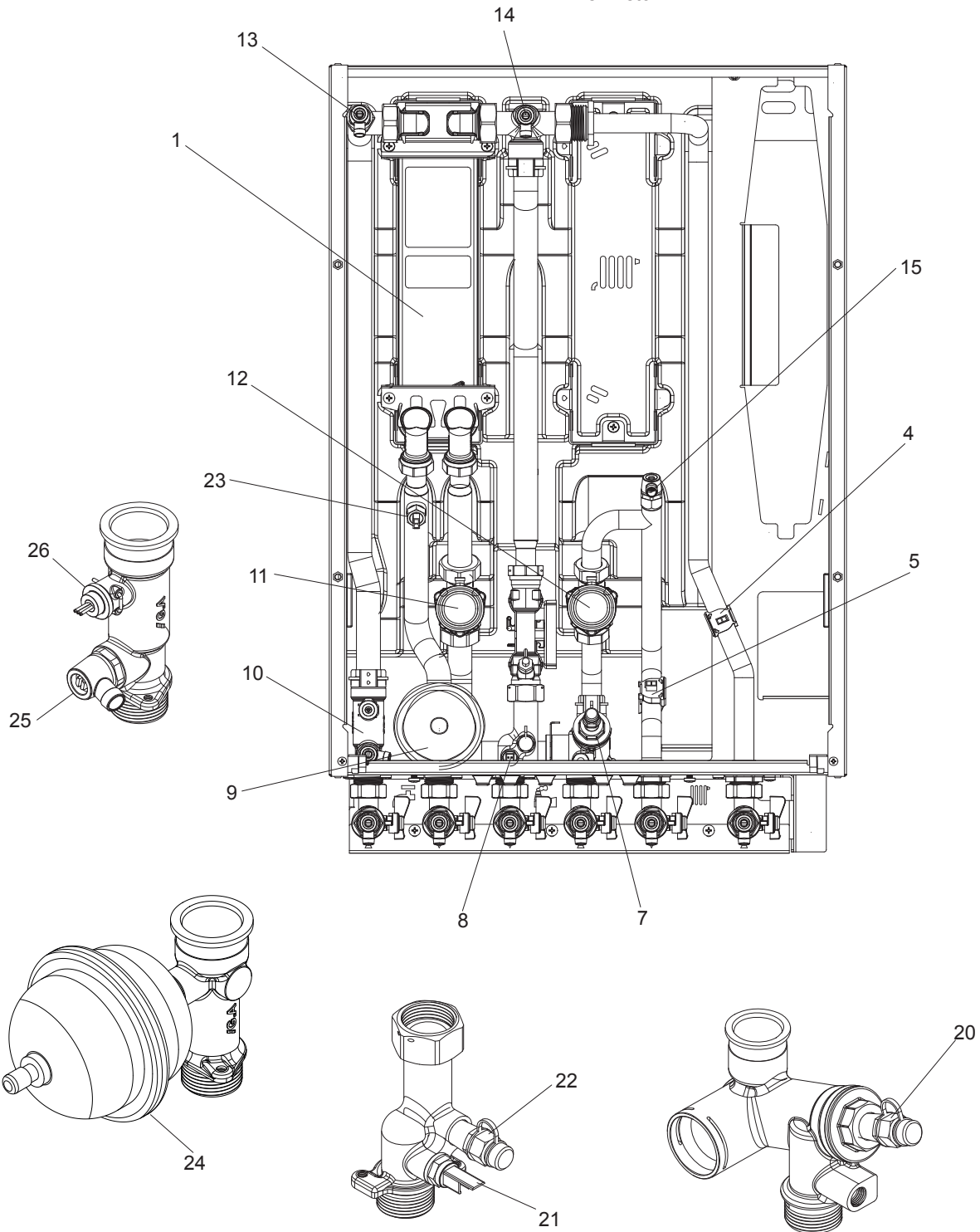

SECTION 3 - SERVICING

3.4 HIU FRONT PANEL REMOVAL / REPLACEMENT

REMOVAL

1. Pull open the door panel.
2. Remove the two screws retaining the front panel on the bottom edge – retain screws.
3. Pull front panel forward from the bottom and lift away to disengage from top retention.

REPLACEMENT

1. Hook the front panel onto the top panel of the HIU, ensure panel is engaged.
2. Push panel against control panel and insert the two retaining screws.
3. Re-tighten the two retaining screws.
4. Close door panel up until engaged.

Note: For removal of insulation and refitting refer to Section 3.12.

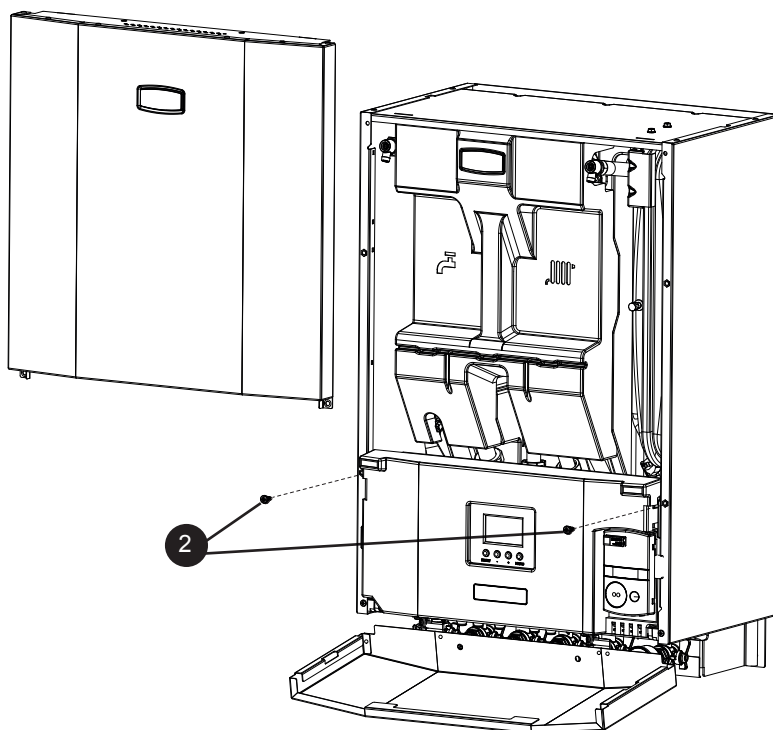

3.5 DRAINING THE HEAT INTERFACE UNIT

IMPORTANT: The primary circuit must only be drained with the permission of the Heat Network service provider.

1. Isolate the appropriate circuit by turning the isolation valves to the off/drain position (handle horizontal).

WARNING – If draining the primary circuit, both flow and return isolation valves **MUST** be isolated. Failure to do this will subject the drain point to system pressure when opened and cause the full system to be drained.

NOTE, INDIRECT UNITS ONLY: Before isolating the DCW supply, the filling loop must be connected with the in line valve turned to the off position. See Section 2.4.

The DCW & central heating circuits cannot be drained via the isolation valve.

DCW: The drain point on the front of the DCW manifold should be used.

CH: The drain point on the underside of the waterset should be used.

2. Connect a hose to the applicable drain point nozzle and route to a container.
3. Slowly open the applicable drain point using the central screw. Care **MUST** be taken while releasing pressure within the circuits, particularly the primary.
4. Slowly open the applicable vent point to improve the flow of fluid from the circuit.
5. Once the flow of fluid has stopped, close the drain point(s) and air vent(s).

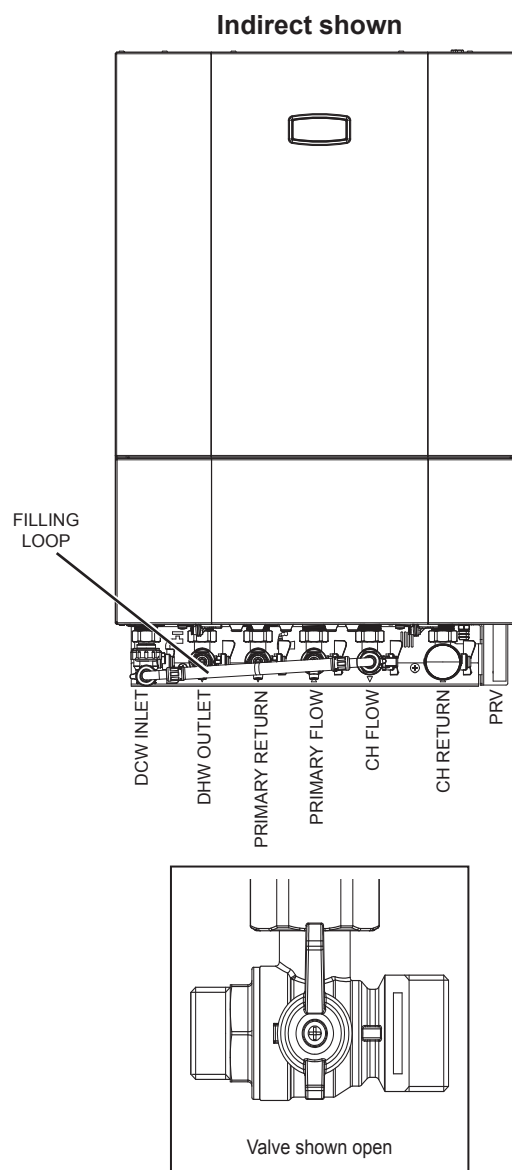

SECTION 3 - SERVICING

3.6 PRIMARY STRAINER REMOVAL, CLEANING & REPLACEMENT

1. Isolate and drain primary circuit – refer to Section 3.5.
2. Refer to Section 3.4 for front panel removal.
3. Completely unscrew the strainer cap and retract strainer carrier from body.
4. Clean the mesh, replace if required.
5. Ensure O-ring is debris and damage free, replace if required.
6. Reassemble in reverse order.
7. Refill circuit and check for leaks.
8. Check that the HIU operates in both DHW & CH modes.

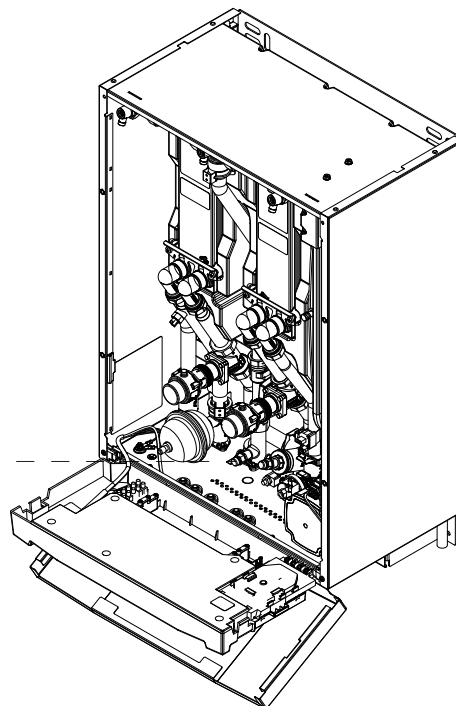
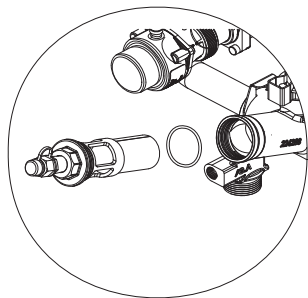

3.7 CH PRESSURE GAUGE REPLACEMENT (INDIRECT ONLY)

1. Drain the CH circuit as per Section 3.5.
2. Unscrew the head of the gauge using the brass nut at the rear of the gauge.
3. Screw the new gauge to the front of the isolation valve. At least 2 threads after the sealing ring must be engaged.
4. Check that the HIU operates in both DHW & CH modes.

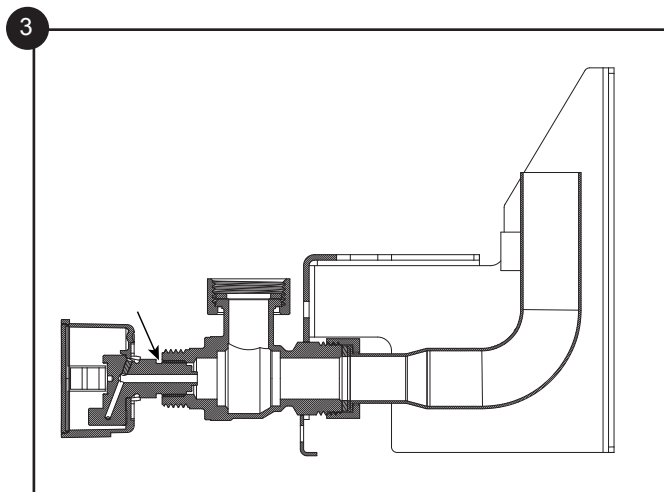
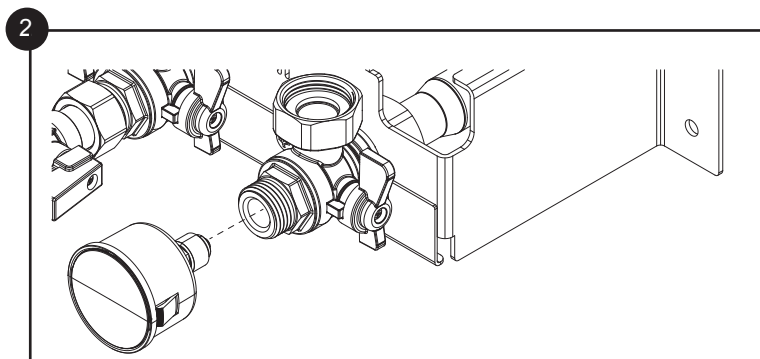

SECTION 3 - SERVICING

3.8 CH EXPANSION VESSEL RECHARGING & REPLACEMENT (INDIRECT ONLY)

RECHARGING

1. Refer to Section 3.4 for front panel removal.
2. Remove the charge point cover.
3. Recharge the tank pressure to 0.75 bar.
4. Re-assemble in reverse order.
5. Check that the HIU operates in both DHW & CH modes.

REPLACEMENT

6. Refer to Section 3.4 for front panel removal.
7. Drain the HIU CH circuit. Refer to Section 3.5.
8. Remove the retaining clip on the vessel water connection pipe and remove the pipe.
9. Support the expansion vessel and unscrew the 2 screws from the securing bracket, located on the top of the HIU, and remove. **(Note the position of the bracket on the vessel).**
10. Remove the expansion vessel.
11. Fit the new expansion vessel.
12. Reassemble in reverse order ensuring the seal is in place.
13. Refill the HIU and check for leaks. Refer to Section 2.5.
14. Check that the HIU operates in both DHW & CH modes.

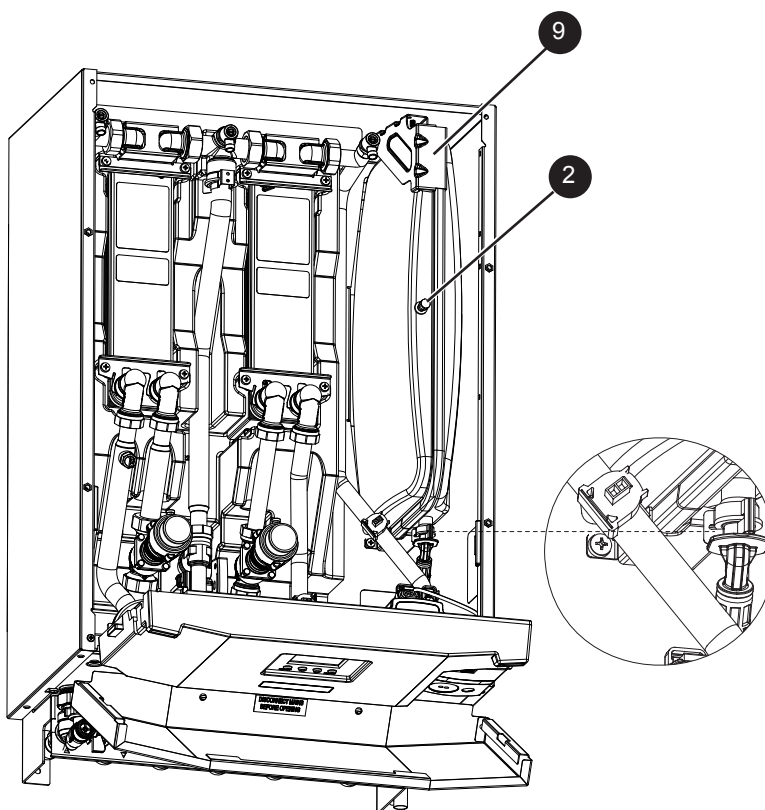

3.9 DHW WATER HAMMER ARRESTOR RECHARGING & REPLACEMENT

RECHARGING

1. Refer to Section 3.4 for front panel removal.
2. Remove the charge point cover.
3. Recharge the tank pressure to 3.5 bar.
4. Re-assemble in reverse order.
5. Check that the HIU operates in both DHW & CH modes.

REPLACEMENT

6. Refer to Section 3.4 for front panel removal.
7. Drain the HIU DHW circuit. Refer to Section 3.5.
8. Using the brass nut at the rear of the hammer arrestor to unscrew from the manifold.
9. Remove the water hammer arrestor.
10. Reassemble in reverse order ensuring the gasket is in place.
11. Refill the HIU and check for leaks. Refer to Section 2.5.
12. Check that the HIU operates in both DHW & CH modes.

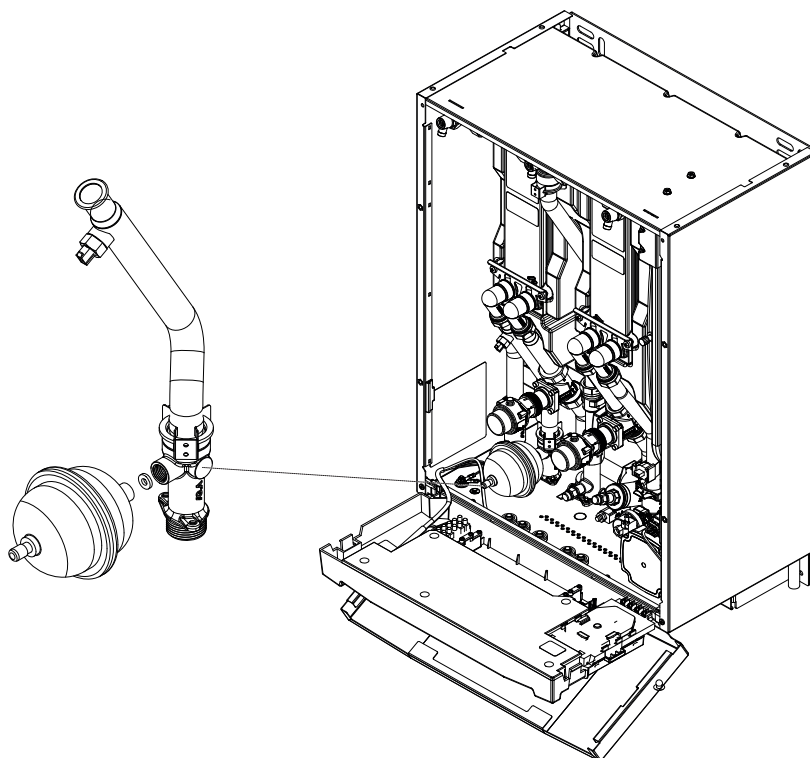

SECTION 3 - SERVICING

3.10 CH CIRCULATION PUMP HEAD REPLACEMENT

1. Refer to Section 3.4 for front panel removal.
2. Isolate and Drain the HIU. Refer to Section 3.5.
3. Disconnect the plug of the low voltage harness from the pump by placing a small flat bladed screw driver into the slot in the clip. Push down lightly to disengage the clip and pull the plug towards you to remove from the pump assembly.
4. Disconnect the plug of the high voltage harness by placing a small flat bladed screw driver into the slot in the clip. Push down lightly to disengage the clip and pull the plug towards you to remove from the pump assembly.
5. Remove the pump head by removing the 4 x allen screws.
6. Fit the new pump head.
7. Reassemble in reverse order
8. Refill the HIU. Refer to Section 2.5.
9. Check that the HIU operates in both DHW & CH modes.

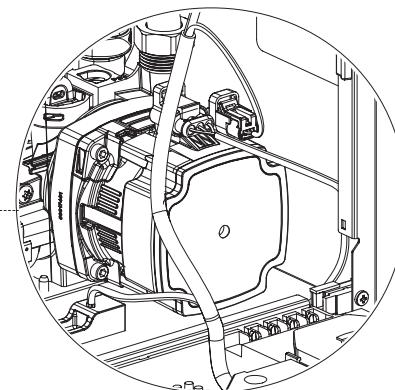
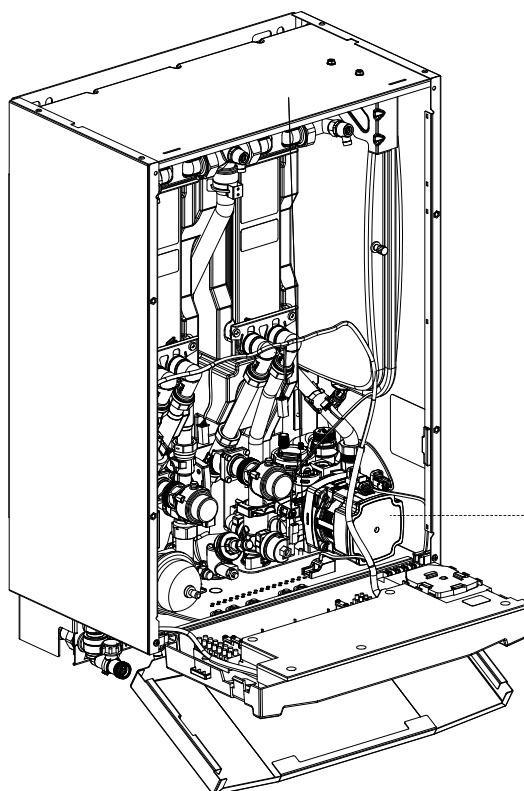

3.11 PUMP AUTOMATIC AIR VENT REMOVAL & REPLACEMENT

1. Refer to Section 3.4 for front panel removal.
2. Isolate and drain the HIU. Refer to Section 3.5.
3. Remove the expansion vessel. Refer to Section 3.8.
4. The automatic air vent head is retained in the pump body with a bayonet connection. The air vent head and float assembly is removed by turning the head anti-clockwise (viewed from above) and pulling upwards. **Note:** There are 2 flat surfaces on the top of the air vent to allow additional grip to help remove the air vent.
 - a. Check the condition of the air vent mounting seal to ensure it is correctly located, and clean replace if necessary.
5. Reassemble in reverse order. Ensure the air vent head 'o' ring seal is fitted.
6. Ensure the air vent cap is loose.
 - a. Check the condition of the pump head mounting seal and clean or replace if necessary.
7. Refill the HIU. Refer to Section 2.5. Check for leaks around the new air vent joint.
8. Check that the HIU operates in both DHW & CH modes.

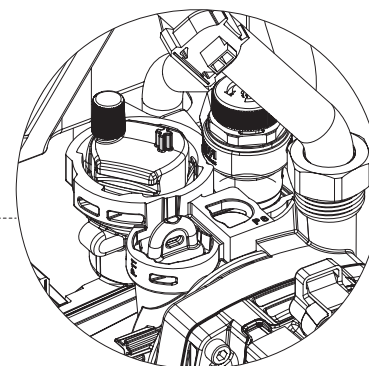
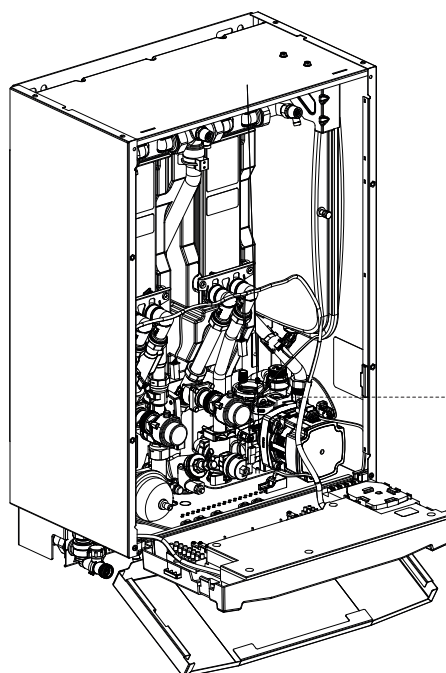

SECTION 3 - SERVICING

3.12 INTERNAL INSULATION FRONT SECTION REMOVAL & REPLACEMENT

1. Refer to Section 3.4 for front panel removal.
2. Remove harness from the insulation channel and lower down.
3. Remove front insulation section by pulling forward and away.
4. Replace insulation front section in reverse order.

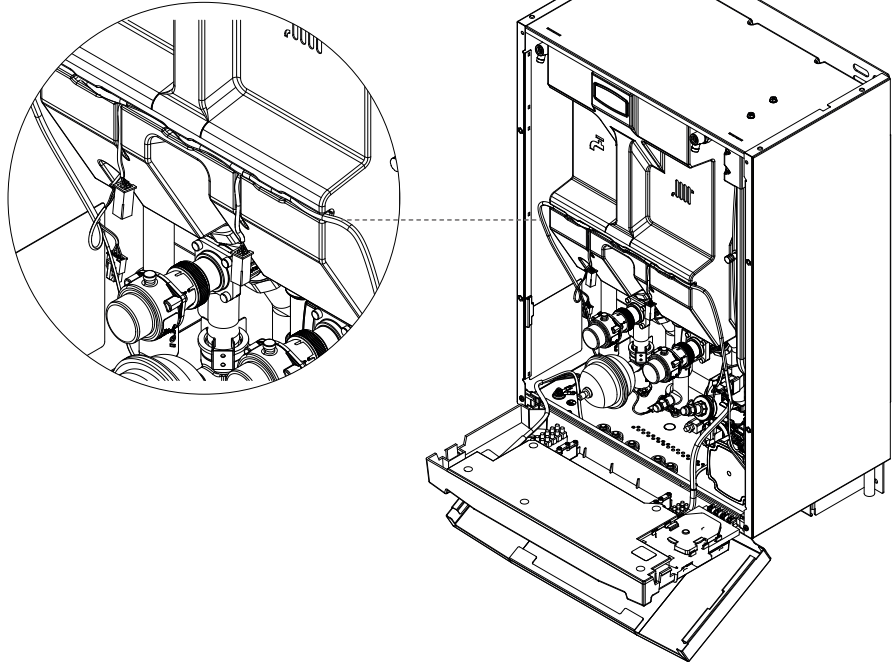

SECTION 3 - SERVICING

3.13 DHW PLATE HEAT EXCHANGER REMOVAL & REPLACEMENT

1. Isolate and drain the HIU. Refer to Section 3.5.
2. Remove the front panel. Refer to Section 3.4.
3. Remove insulation front section to expose plate heat exchanger(s). Refer to Section 3.12.
4. Slacken the four pipe nuts on the front face of the LHS plate. Ensure support is used to not twist the elbow manifolds. Dispose of fibre washers to prevent re-use.
5. Remove the four screws securing the two plate heat exchanger retention brackets (upper and lower) to the chassis.
6. Manoeuvre the plate heat exchanger out of the appliance. Be aware of any water spillage.
7. Remove the clips from the plate heat exchanger by pulling the upper one downward and the lower one upward. Lightly twist and pull the elbows to remove them from the O-ring seals on the PHE.
8. Fit new blue O-ring seals to the upper most groove on the 4 PHE connection posts (the low groove nearest the PHE is for the retention clip).
9. Ensure the two indents near the PHE connection posts are facing inboard.
10. Refit the two 90° elbows to the top of the PHE with their outlets facing left and right, and the 2 x 60° elbows are fitted with their outlet facing downwards.

Note: Failure to correctly locate the position of the elbows will prevent the retention clips from being fitted.

11. Ensure new retention clips are located correctly in the slots on the brass elbows and that they are secured to the correct groove on the PHE connect post. **Note:** If they are not correctly fitted the groove nearest the PHE will be clearly visible. In this case the clip will need to be removed and the elbows pushed further on the PHE connection posts and the clip refitted.
 12. Fit the new plate heat exchanger into the cut out in insulation back panel – ensure DHW plate size is matched to plate removed.
- Note:** Ensure that the depressions on the plate heat exchanger are facing inboard and match the insulation.
13. Refit the four screws securing the upper and lower bracket to the chassis, including the upper manifold bracket.
 14. Replace fibre washers with new (supplied) and spin nuts onto manifold threads.
 15. Torque the 90 degree manifold (TOP) pipe nut connections to 40N/m.
 16. Torque the 60 degree manifold (BOTTOM) pipe nut connections to 32N/m.
 17. Refill the HIU. Refer to Section 2.5.
 18. Replace the insulation front section. Refer to Section 3.12.
 19. Check that the HIU operates in both DHW & CH modes.

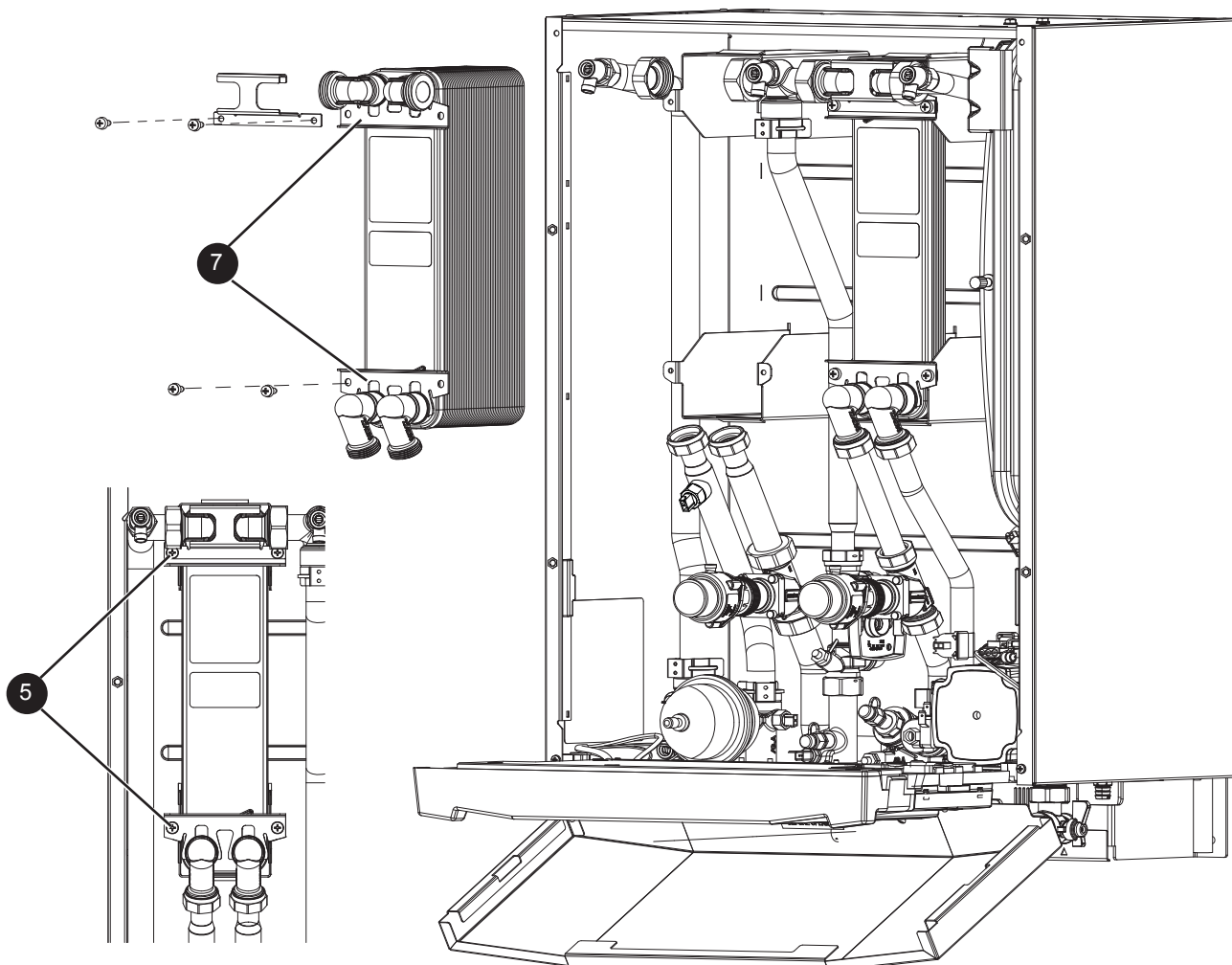

SECTION 3 - SERVICING

3.14 CH PLATE HEAT EXCHANGER REMOVAL & REPLACEMENT

1. Isolate and drain the HIU. Refer to Section 3.5.
2. Remove the front panel. Refer to Section 3.4.
3. Remove insulation front section to expose plate heat exchanger(s). Refer to Section 3.12.
4. Slacken the four pipe nuts on the front face of the RHS plate. Ensure support is used to not twist the elbow manifolds. Dispose of fibre washers to prevent re-use.
5. Remove the four screws securing the two plate heat exchanger brackets (upper and lower) to the chassis.
6. Manoeuvre the plate heat exchanger out of the appliance. Be aware of any water spillage.
7. Remove the clips from the plate heat exchanger by pulling the upper one downward and the lower one upward. Lightly twist and pull the elbows to remove them from the O-ring seals on the PHE.
8. Fit new blue O-ring seals to the upper most groove on the 4 PHE connection posts. (the low groove nearest the PHE is for the retention clip).
9. Ensure the two indents near the PHE connection posts are facing inboard.
10. Refit the two 90° elbows to the top of the PHE with their outlets facing left and right, and the 2 x 60° elbows are fitted with their outlet facing downwards.

Note: Failure to correctly locate the position of the elbows will prevent the retention clips from being fitted.

11. Ensure new retention clips are located correctly in the slots on the brass elbows and that they are secured to the correct groove on the PHE connect post. **Note:** If they are not correctly fitted the groove nearest the PHE will be clearly visible. In this case the clip will need to be removed and the elbows pushed further on the PHE connection posts and the clip refitted.
 12. Fit the new plate heat exchanger into the cut out in insulation back panel – ensure CH plate size is matched to plate removed.
- Note:** Ensure that the depressions on the plate heat exchanger are facing inboard and match the insulation.
13. Refit the four screws securing the upper and lower bracket to the chassis, including the upper manifold bracket.
 14. Replace fibre washers with new (supplied) and spin nuts onto manifold threads.
 15. Torque the 90 degree manifold (TOP) pipe nut connections to 40N/m.
 16. Torque the 60 degree manifold (BOTTOM) pipe nut connections to 32N/m.
 17. Refill the HIU. Refer to Section 2.5.
 18. Replace the insulation front section. Refer to Section 3.12.
 19. Check that the HIU operates in both DHW & CH modes.

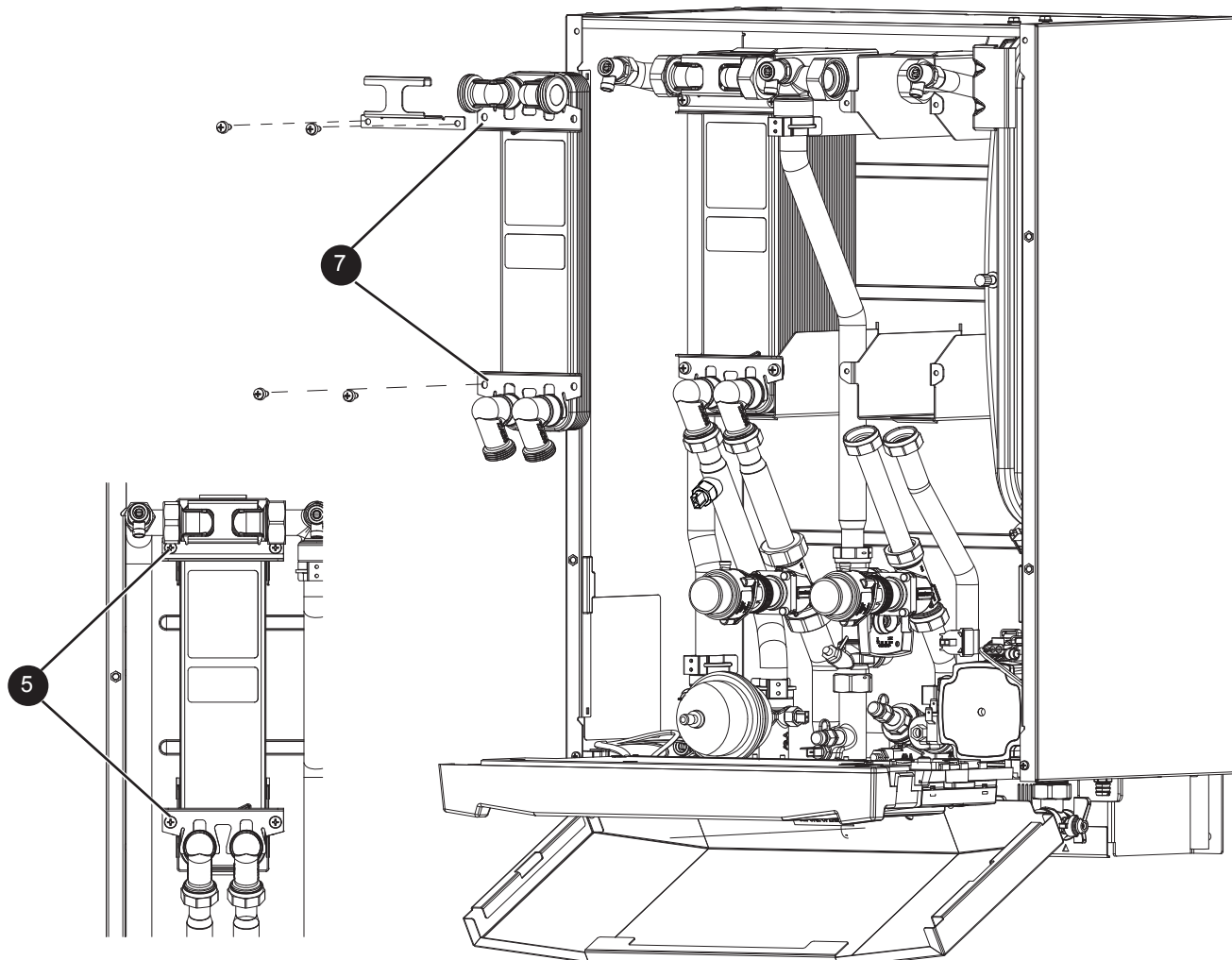

SECTION 3 - SERVICING

3.15 CH WATER PRESSURE SWITCH REMOVAL & REPLACEMENT

1. Isolate and drain the HIU. Refer to Section 3.5.
2. Remove the front panel. Refer to Section 3.4.
3. Pull off the two electrical connections.
4. Using a suitable tool, pull out the metal retaining clip.
5. Carefully withdraw the pressure switch. Check the sealing 'O' ring is clean, undamaged and fitted in the correct location.
6. Fit the new pressure switch and re-assemble in reverse order.
7. Refill the HIU. Refer to Section 2.5.
8. Check that the HIU operates in both DHW & CH modes.

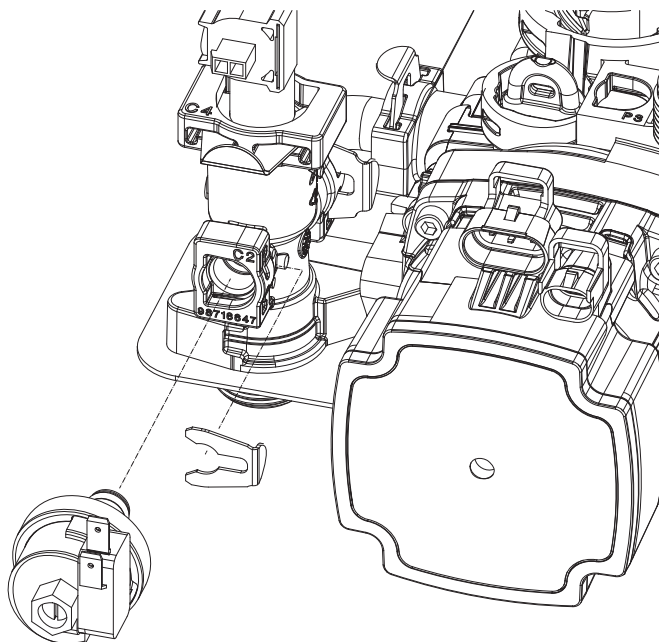

3.16 PRIMARY RETURN THERMISTOR

1. Isolate and drain down the HIU. Refer to Section 3.5.
2. Remove the front panel. Refer to Section 3.4.
3. Unplug the electrical lead from the thermistor.
4. Unscrew the thermistor (to facilitate removal a 13mm socket spanner should be used).
5. Fit the new thermistor using the sealing washer provided.
6. Reassemble in the reverse order.
7. Refill the HIU. Refer to Section 2.5.
8. Check that the HIU operates in both DHW & CH modes.

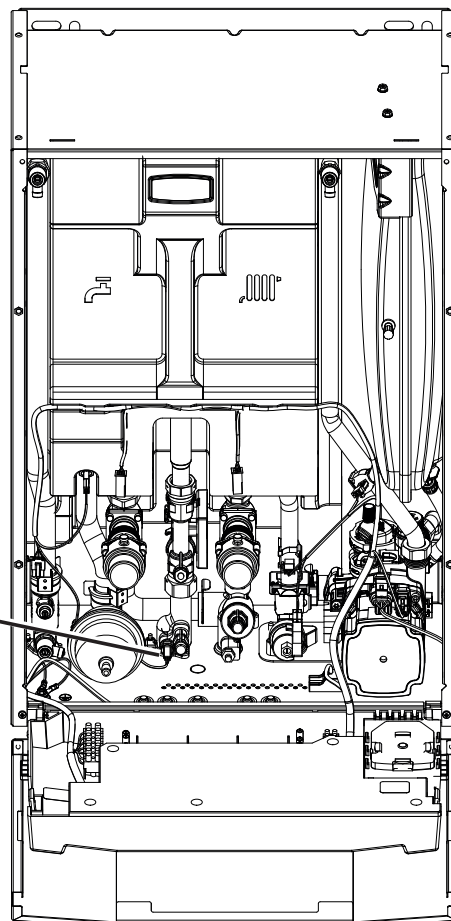
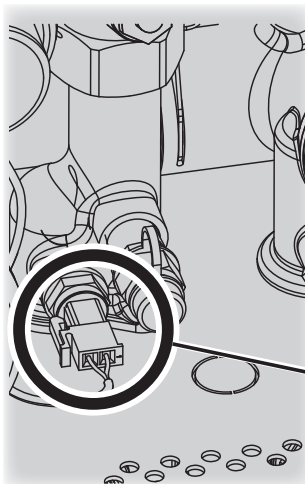

SECTION 3 - SERVICING

3.17 DOMESTIC HOT WATER THERMISTOR

1. Isolate and drain down the HIU.
Refer to Section 3.5.
2. Remove the front panel. Refer to Section 3.4.
3. Remove front insulation section.
Refer to Section 3.12.
4. Unplug the electrical lead from the thermistor.
5. Unscrew the thermistor (to facilitate removal a 13mm socket spanner should be used).
6. Fit the new thermistor.
7. Reassemble in the reverse order.
8. Refill the HIU. Refer to Section 2.5.
9. Check that the HIU operates in both DHW & CH modes.

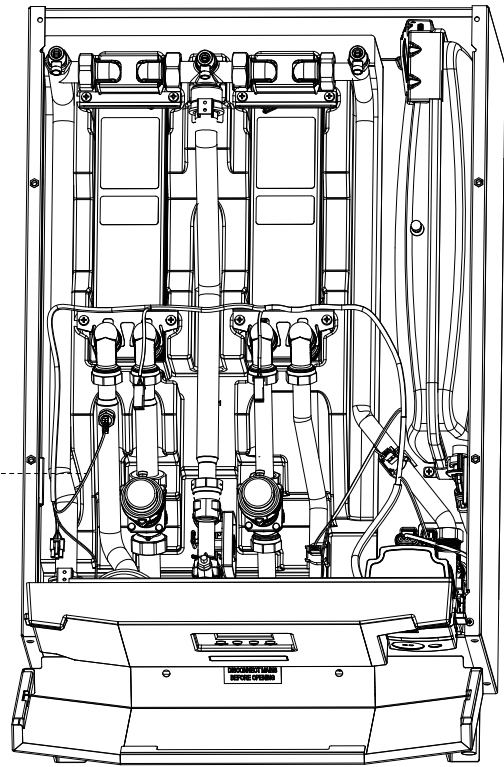
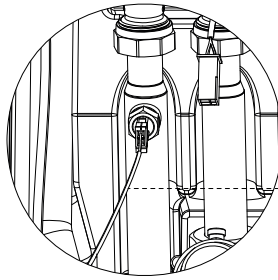

3.18 CH FLOW & RETURN THERMISTOR

1. Remove the front panel. Refer to Section 3.4.
2. Unplug the electrical lead from the thermistor.
3. Unclip the thermistor from the pipework.
4. Fit the new thermistor ensuring it is positioned on the brass tab.
5. Reassemble in the reverse order.
6. Check that the HIU operates in both DHW & CH modes.

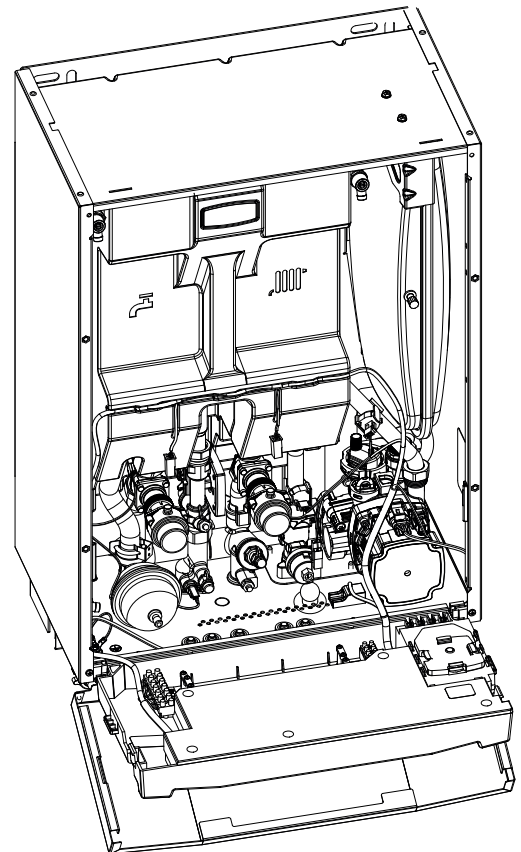
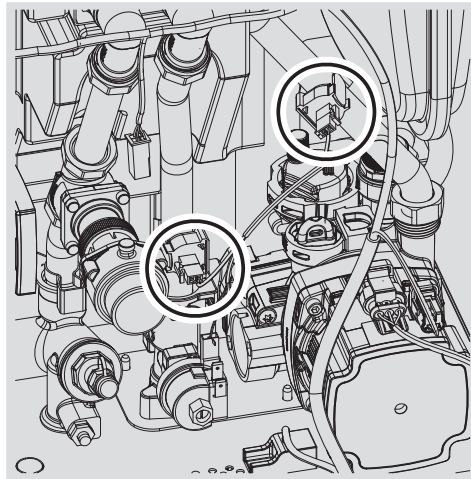

SECTION 3 - SERVICING

3.19 CH PRESSURE RELIEF VALVE

1. Isolate and drain down the HIU's CH circuit
Refer to Section 3.5.
2. Pull out and remove the clip (positioned at the rear of the water set) retaining the Pressure Relief Valve (PRV).
3. Undo the PRV outlet pipe connection and disconnect from the PRV.
4. Twist and pull the PRV upward to remove it from the manifold.
5. Reassemble in reverse order ensuring the retaining clip is correctly fitted, the pipe compression fitting re-tightened and return thermistor is re-clipped. **Note: Ensure the pipe is fitted in the chassis channel.**
6. Check the 'O' ring seal is clean and correctly fitted. Refill the HIU. Refer to Section 2.5.
7. Check that the HIU operates in both DHW & CH modes.
8. Check the operation of the PRV by rotating the top of the PRV briefly to ensure it discharges water and reseals.

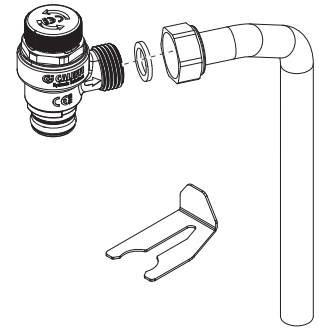
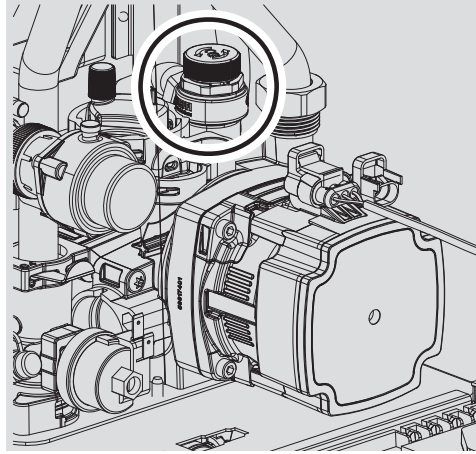

SECTION 3 - SERVICING

3.20 PCB REMOVAL & REPLACEMENT

Note: Fit the earth strap to your wrist and secure to a suitable earth on the HIU chassis.

1. Ensure the HIU is disconnected from the Mains power supply and if the credit control valve is fitted ensure this is also powered down to prevent exposure to mains electricity.
2. Refer to Section 3.4 to remove front panel.
3. Gently fold down the plastic front panel to expose the back of the control box enclosure.
4. Remove the 5 screws and lift the back plastic panel away.
5. Unplug all connections to PCB.
6. Remove two screws which retain PCB in position.
7. Lift the PCB out of the plastic enclosure.
8. Ensure all control board selection buttons are correctly located in the front panel before refitting the new PCB.
9. Place new PCB inside plastic enclosure and reassemble in reverse order.
10. Once the HIU front panel is secured switch the mains power on to begin setting up the new PCB parameters.
11. a. On power up the new PCB will show 'uP'.
 - b. Press RESET, display now shows 'oF'.
 - c. Power down the HIU at the mains, wait for 10 seconds and power on again.
 - d. Display shows 'F9'.
 - e. Press the '+' or '-' button to progress to the HIU type setting screen.
 - f. Using the '+' or '-' button the display will be able to be cycled between available parameter sets.
 - g. Choose the parameter set number for the appliance model according to the list in Section 2.12.13. Once

the correct HIU type has been chosen, press the Menu button to progress.

- h. The display will indicate the model type that has been selected, viewable only.
 - II = Indirect/indirect
 - dl = Direct/indirect
 - It = N/A
 - Dt = N/A
- j. Press the Menu button to advance.
- k. The display will indicate the DHW capacity that has been selected, viewable only.
 - Indirect (II) 30, 40, 50, 60 or 70 kW
 - Direct (dl) 30, 40, 50 or 60 kW
- l. Press the Menu button to advance.
- m. Press the '+' or '-' button to adjust the maximum DHW flow temperature. Range 35 - 65°C.
- n. Press the Menu button to advance.
- o. Press the '+' or '-' button to adjust the maximum CH flow temperature. Range 35 - 80°C.

NB: This feature allows the installer to limit the flow temperatures to protect underfloor heating systems and/or vulnerable users.

- p. Press the Menu button to resume normal operation.
- q. Power down the HIU at the mains, wait for 10 seconds and power up again. This will ensure the primary control valves are calibrated correctly for the HIU type.

The HIU is now ready for normal operation.

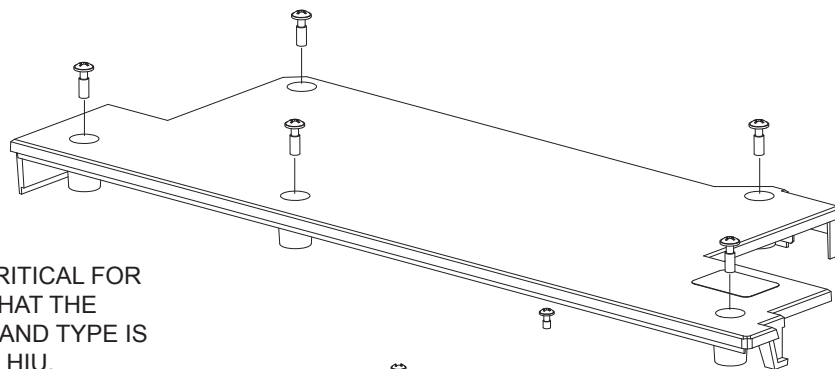

IMPORTANT. IT IS CRITICAL FOR SAFE OPERATION THAT THE CORRECT HIU SIZE AND TYPE IS ENTERED INTO THE HIU.

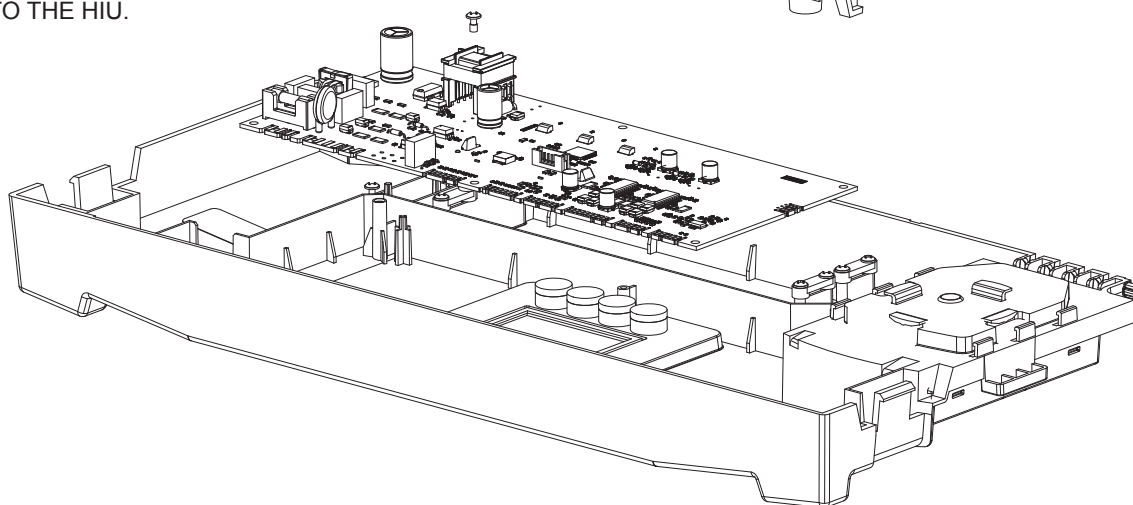

SECTION 3 - SERVICING

3.21 DHW FLOW REGULATOR

1. Isolate and drain down the HIU. Refer to Section 3.5.
2. Remove the front panel. Refer to Section 3.4.
3. Remove insulation front section. Refer to Section 3.12.
4. Disconnect the connector on the flow turbine harness.
5. Slacken and disconnect isolation valve nut on the mains DCW feed into the HIU appliance on the first fix bracket.
6. Remove and retain the two screws securing the manifold to the bottom panel.
7. Slacken and disconnect pipe nut into the DHW plate from the cold feed (top left of plate heat exchanger).
8. Lift up and rotate cold water feed pipe leg with manifold attached out from the HIU.
9. Using a pair of pliers, pull out/remove plastic flow regulator.
10. Clean the inlet mesh filter, check the O-ring seal and refit with the filter mesh facing outward. If replacing the flow restrictor cartridge, ensure that it is correctly sized for the unit it is been fitted to and cartridge colour coding is the same.
11. Re-assemble in reverse order, replacing all gaskets where appropriate.
12. Refill the HIU. Refer to Section 2.5.
13. Check that the HIU operates in both DHW & CH modes.

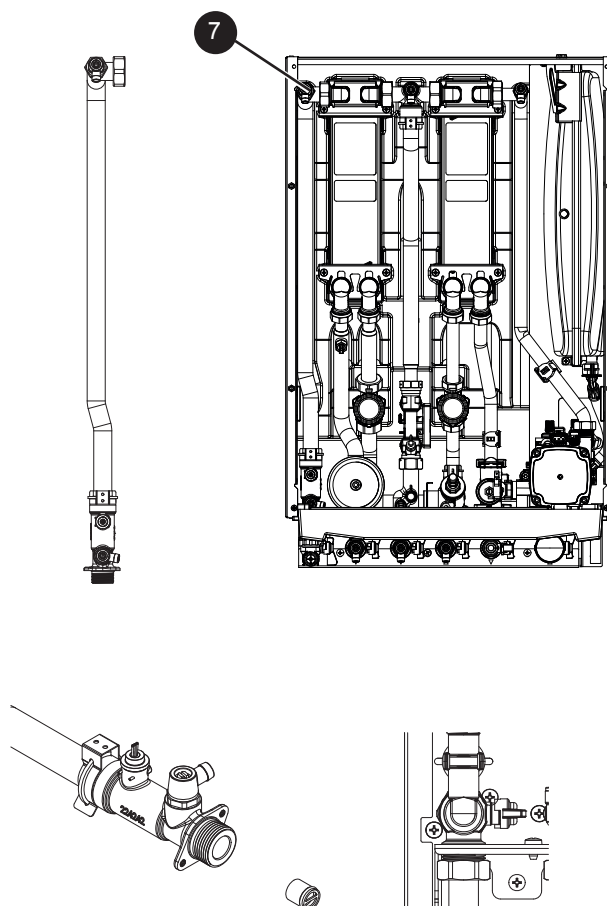

3.22 DHW FLOW MANIFOLD WITH INTEGRATED TURBINE ASSEMBLY REPLACEMENT

1. Isolate and drain down the HIU. Refer to Section 3.5.
2. Remove the front panel. Refer to Section 3.4.
3. Remove insulation front section. Refer to Section 3.12.
4. Disconnect the connector on the flow turbine harness.
5. Slacken and disconnect isolation valve nut on the mains DCW feed into the HIU appliance on the first fix bracket.
6. Remove and retain the two screws securing the manifold to the bottom panel.
7. Slacken and disconnect pipe nut into the DHW plate from the cold feed (top left of plate heat exchanger).
8. Lift up and rotate cold water feed pipe leg with manifold attached out from the HIU.
9. Using a suitable tool retract the metal pipe clip and remove the pipe from the manifold.
10. Using a pair of pliers pull out / remove the plastic flow regulator from the base of the manifold inlet. Make sure the complete cartridge has been removed from the inlet of the manifold.
11. Clean the inlet mesh filter, check the O-ring seal and refit with the filter mesh facing outward. If replacing the flow restrictor cartridge, ensure that it is correctly sized for the unit it is been fitted to and cartridge colour coding is the same.
12. Replace the O-ring on the cold water feed pipe and insert into new DHW flow turbine housing manifold.
13. Re-assemble metal pipe clip.
14. Re-assemble in reverse order, replacing all gaskets where appropriate.
15. Refill the HIU. Refer to Section 2.5.
16. Check that the HIU operates in both DHW and CH modes.

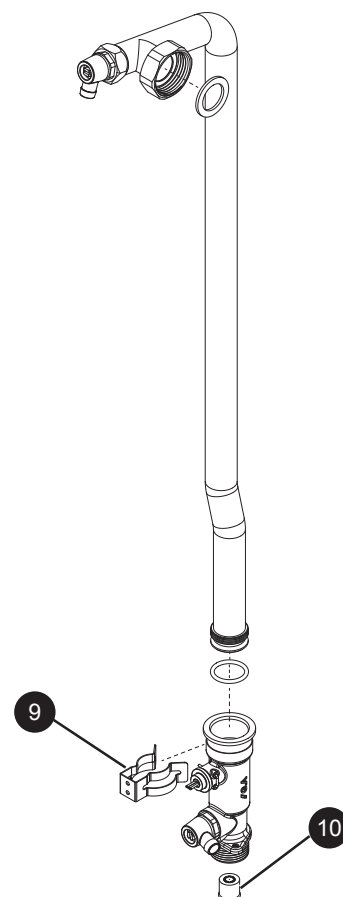

SECTION 3 - SERVICING

3.23 DHW PICV

1. Isolate the mains electrical supply.
2. Remove the front panel. Refer to Section 3.4.
3. Remove insulation front section to expose plate heat exchanger(s). Refer to Section 3.12.
4. Isolate and drain the HIU. Refer to Section 3.5.
5. Disconnect the electrical connector to the PICV actuator.
6. Unscrew the actuator from the PICV body.
7. Loosen the upper and lower connection nuts each side of the PICV body.
8. Remove the PICV body from the 2 pipes.
9. Using new sealing washers refit the new PICV body. Note the flow direction arrow and the position of the valve.
10. Tighten the valve body onto the associated pipe work.
11. Refill in accordance with Section 2.5 "primary circuit filling" and check for leaks.
12. Refit the actuator to the PICV body, Make sure the thread travels the full length of the valve body thread.
13. Refit electrical connection.

Note: If the actuator does not travel the majority of the valve body's actuator mounting thread, turn the mains on and activate a DHW delivery. This will open the valve and allow the actuator mounting collar to be tighten fully on to the valve. The unit must be then turned off at the mains and back on to allow the valve to recalibrate its position.

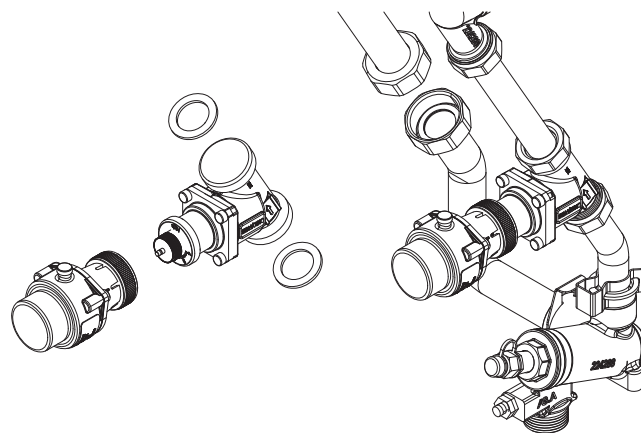

3.24 CH PICV

1. Isolate the mains electrical supply.
2. Remove the front panel. Refer to Section 3.4.
3. Remove insulation front section to expose plate heat exchanger(s). Refer to Section 3.12.
4. Isolate and drain the HIU. Refer to Section 3.5.
5. Disconnect the electrical connector to the PICV actuator.
6. Unscrew the actuator from the PICV body.
7. Loosen the upper and lower connection nuts each side of the PICV body.
8. Remove the PICV body from the 2 pipes.
9. Using new sealing washers refit the new PICV body note the flow direction arrow and the position of the valve.
10. Tighten the valve body onto the associated pipe work.
11. Refill in accordance with Section 2.5 and check for leaks.
12. Refit the actuator to the PICV body. Make sure the thread travels the full length of the valve body thread.
13. Refit electrical connection.

Note: If the Actuator does not travel the majority of the valve body's actuator mounting thread, turn the mains electrical supply on and activate a CH delivery this will open the valve and allow the actuator mounting collar to be tighten fully on to the valve. The unit must be then turned off at the mains and back on to allow the valve to recalibrate its position.

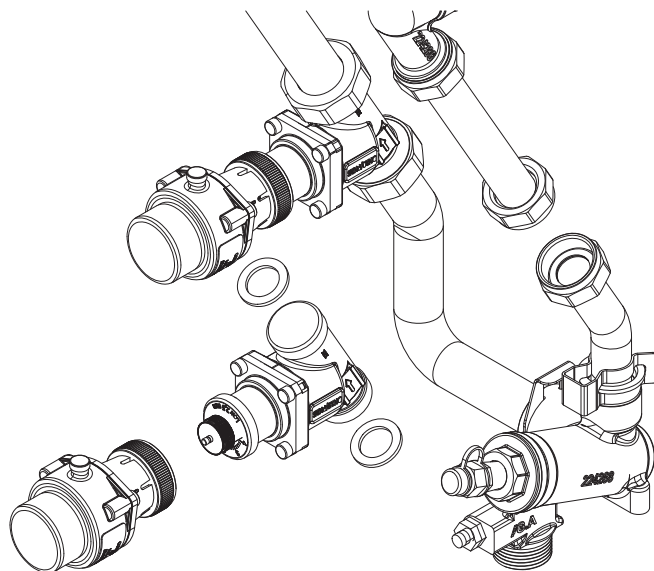

SECTION 3 - SERVICING

3.25 HEAT METER INSTALLATION

Note: This unit is designed to be fitted with the Ideal HIU Heat Meter only.

1. Isolate and drain down the HIU. Refer to Section 3.5.
2. Remove the front panel. Refer to Section 3.4.
3. Remove insulation front section. Refer to Section 3.12.
4. Slacken and disconnect the pipe nuts from the blanking pipe and remove.
5. Install the flow meter with new gaskets. Ensure orientation is as with flow direction arrow pointing down.

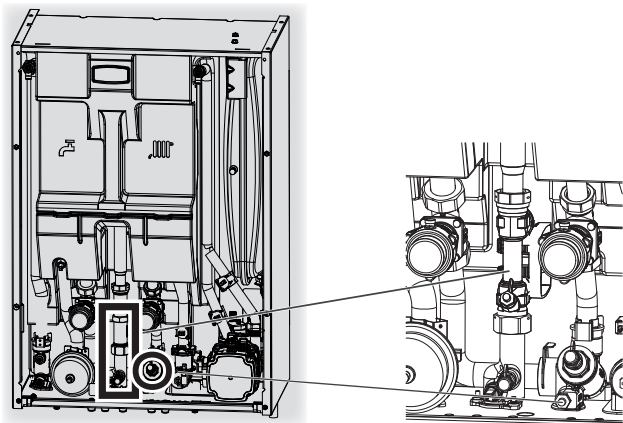

Pipe blank & blanking
plug position shown

6. Remove blanking plug and gasket from Primary flow filter manifold.
7. Use the tool provided to position the O-ring inside the primary flow filter manifold.
8. Place both halves of the plastic adapter around the 3 notches of the temperature sensor.
9. Press the adapter together and screw hand tight (3 – 5 Nm) into the primary flow filter manifold.

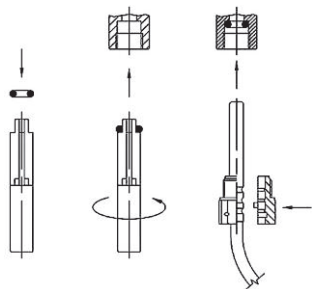

10. Lift the right-hand side of the control panel out of its hinge mounting and feed the 4 wires (3 if wireless MBUS) under the lower part of the panel below the hinge point.
11. Refit the control panel back into its hinge point taking care not to trap the wires.

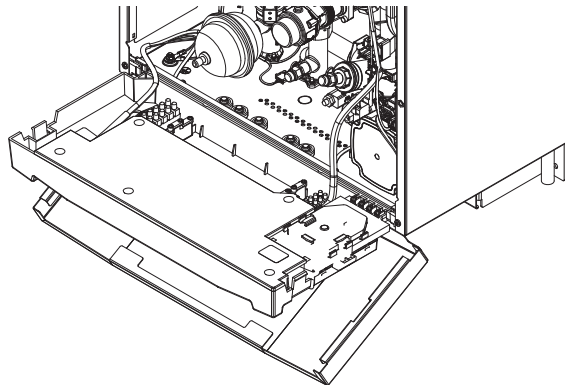

12. Place the display in the lower part of the cut out on the right-hand side of the outer control panel and slide it upward until it engages in the meter mounting clips that are moulded into the control panel.
13. Clip the 4 wires (3 if wireless MBUS) into the control box retention channels directly below the heat meter.

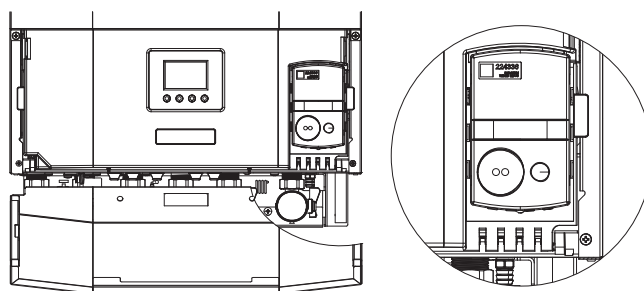

Continued....

SECTION 3 - SERVICING

- Lower the control panel and gather up the excess wires and cable tie them inside the front return lip of the right-hand side panel.
- Connect the MBUS to the additional MBUS communication device if fitted. Secure the excess metering cable to the plastic retention clips behind the heat meter body, using cable ties if required.

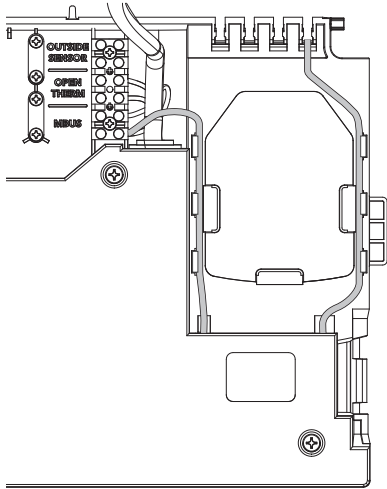

- Refill the primary HIU circuit as per Section 2.5 and check for leaks.
- Activate the meter and follow the heat meter instructions provided to commission and setup the meter.
- Ensure control box cover can move freely and the front panel can be secured without trapping any cables.
- Run the MBUS cable from the building management system through one of the rubber strain relief grommets and screw into the terminal strip labelled MBUS. Secure this cable using the plastic cable retention bracket.
- Operate the unit and ensure the heat meter is functioning (refer to the Heat Meter user instructions).

The Heat Meter instructions can be found online at:

https://www.bmeters.com/en/bm_product/hydrosonis-ulc/

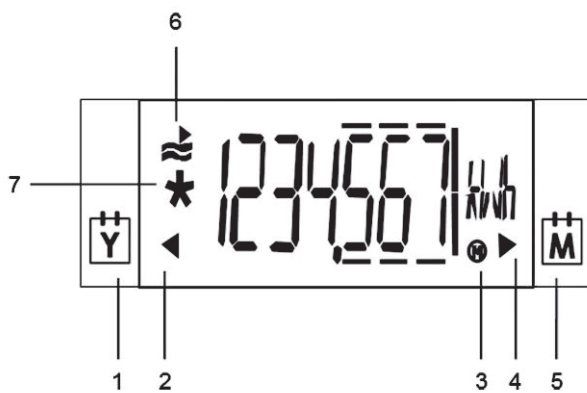

SECTION 4 - FAULT FINDING

4. FAULT FINDING

4.1 DISPLAY FAULTS

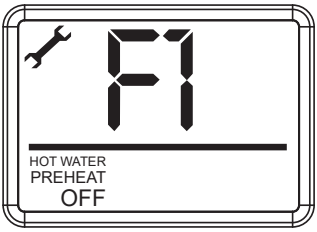
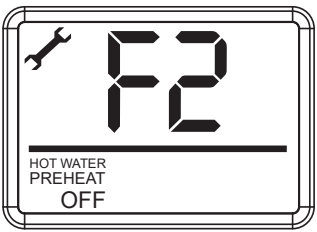
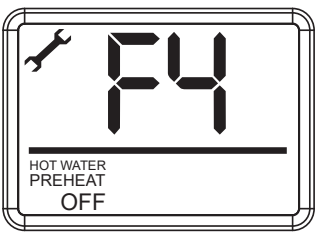
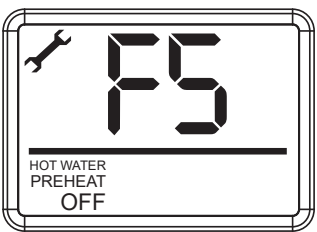
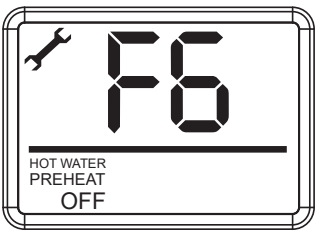
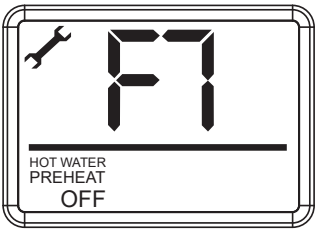
Display	Fault	Action
	Low Water Pressure	Check system water pressure is between 1 and 1.5 bar on the system pressure gauge. If system pressure is low top up the CH circuit as per the steps in Section 2.5. If system pressure is higher than 1.5 bar ensure the system is cold and carefully reduce the pressure using the draining point on a system radiator. If fault persists, replace water pressure switch (see Section 3.15).
	No change in DHW Temperature during demand period	Ensure primary circuit is correctly pressurised and primed to the correct operating temperatures. Check primary circuit is fully open and all isolation valves at base of HIU are open. Ensure all air is purged from primary circuit. If a CCV (credit control valve) is installed in appliance, ensure dwelling has sufficient credit to open valve and wiring to valve has good continuity – Refer to CCV installer and servicing guide for details.
	Flow Thermistor Fault	Remove harness to CH clip on flow thermistor and using a multi-meter measure the resistance of the thermistor – This should be around 10kΩ in ambient conditions. If thermistor is functioning correctly reconnect harness to flow thermistor and reset unit. If thermistor is not functioning correctly replace item. If fault persists, replace PCB (see Section 3.20).
	Return Thermistor Fault	Remove harness to return to CH clip on thermistor and using a multi-meter measure the resistance of the thermistor – This should be around 10kΩ in ambient conditions. If thermistor is functioning correctly reconnect harness to flow thermistor and reset unit. If thermistor is not functioning correctly replace item. If fault persists, replace PCB (see Section 3.20).
	Outside Sensor Open Circuit	Remove outside sensor wiring from screw terminals on the back off the HIU controls enclosure (see Section 2.9 for wiring locations). Using a multi-meter check resistance and continuity to outside sensor: At 0°C expect 31,000 - 35,000 Ohms At 15°C expect 15,000 - 16,500 Ohms At 30°C expect 7,700 - 8,500 Ohms If the thermistor has an open circuit or short circuit replace outside sensor and wiring to outside sensor. Reset the HIU. If problem persists, replace PCB.
	Incorrect Mains Voltage	Contact a qualified electrician, the building manager, or the electricity provider.

Continued...

SECTION 4 - FAULT FINDING

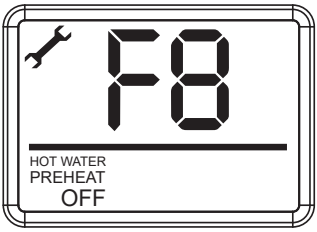
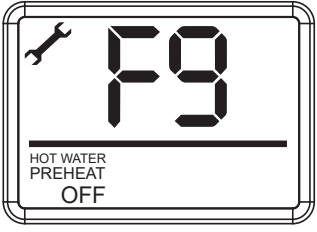
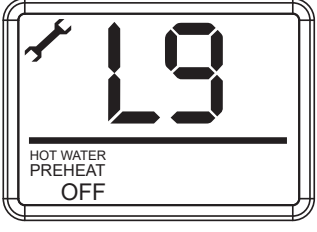
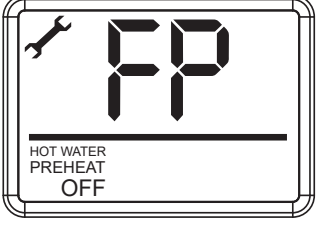
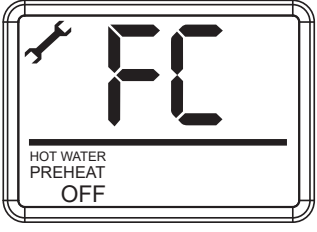
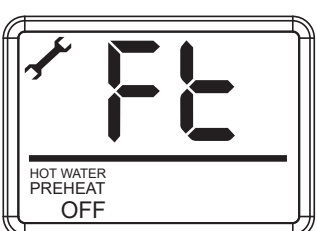
Display	Fault	Action
	Primary Thermistor Fault	Remove harness to primary return thermistor and using a multi-meter measure the resistance of the thermistor – This should be around 10kΩ in ambient conditions. If thermistor is functioning correctly reconnect harness to flow thermistor and reset unit. If thermistor is not functioning correctly replace item. If fault persists, replace PCB (see Section 3.20).
	PCB Fault	Replace PCB using the process as shown in Section 3.20.
	PCB Fault	Replace PCB using the process as shown in Section 3.20.
	Pump Failure	Check system water pressure is between 1 and 1.5 bar on the system pressure gauge. If system pressure is low increase the pressure using the filling loop (see Section 2.5). Check system for blockages and flush system if necessary. If fault persists, replace pump (see Section 3.10).
	DHW Thermistor Fault	Remove harness to DHW thermistor and using a multi-meter measure the resistance of the thermistor – This should be around 10kΩ in ambient conditions. If thermistor is functioning correctly reconnect harness to flow thermistor and reset unit. If thermistor is not functioning correctly replace item. If fault persists, replace PCB (see Section 3.20).
	OpenTherm Plus Fault	Check connection between smart thermostat and HIU. Refer to Smart thermostat manual fault finding.

SECTION 4 - FAULT FINDING

4.2 ADDITIONAL FAULT FINDING

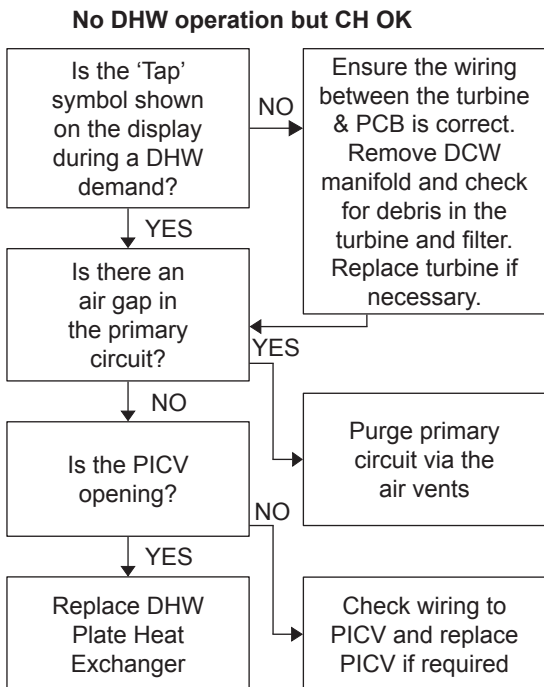
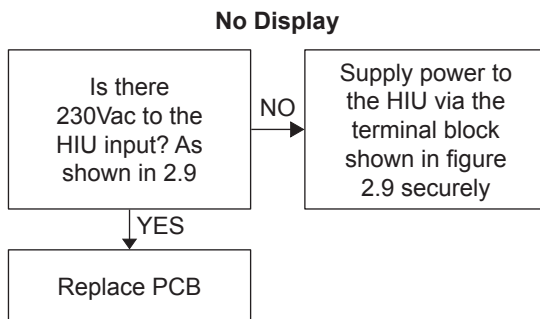
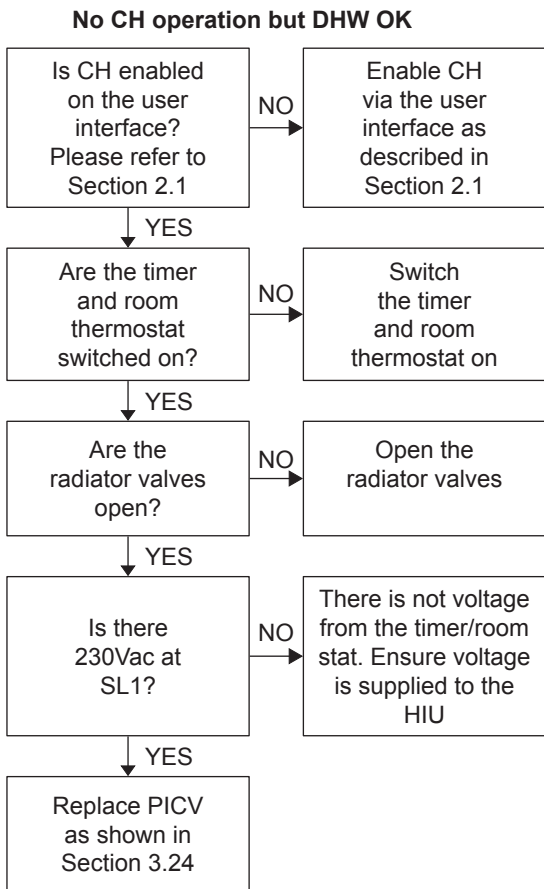

SECTION 4 - FAULT FINDING

4.3 FAULT CODES - NUMERIC

Code	Fault	Display	Type/Action
1	CH Flow Thermistor Open Circuit	F4	CH Valve to mid-position
2	CH Flow Thermistor Short Circuit	F4	CH Valve to mid-position
3	CH Return Thermistor Open Circuit	F5	Pump Modulation lost
4	CH Return Thermistor Short Circuit	F5	Pump Modulation lost
5	CH Primary Return Thermistor Open/Short Circuit	F8	Preheat Disabled
7	DHW Thermistor Open Circuit	FC	DHW Valve to closed position
8	DHW Thermistor Short Circuit	FC	DHW Valve to closed position
9	Outside Sensor Open Circuit	F6	Reverts to max flow target
10	Water Pressure Sensor Fault	F1	No CH operation
11	DHW Sensor disconnected from pipe	FC	DHW Valve to closed position
51	Low Water Pressure	F1	No CH operation
63	High Mains Voltage	N/A	N/A
64	Low Mains Voltage	F7	Blocking
65	OpenTherm Plus Fault (comms lost)	Ft	N/A
67	No Water Flow (from pump)	FP	Blocking CH
68	Pump Rotor Blocked	FP	Blocking CH
69	Low Voltage (from pump)	FP	Indication
70	Water Flow < 2l/min (from Pump)	FP	Blocking CH
71	Dry Run (from Pump)	FP	Blocking CH
72	Pump Warning Code	FP	Indication
94	PCB Fault (request for re-update)	F9	Blocking
95	PCB Fault (blocking due to programming Mode)	F9	Blocking
96	PCB Fault (lockout parameter mismatch)	L9	Lockout
97	PCB Fault (parameter set fault)	F9	Blocking
98	PCB Fault (Internal Blocking Error)	F9	Blocking
99	PCB Fault (internal lockout)	L9	Lockout
	No Change detected in DHW or Flow Temp	F2	Blocking

5. SPARE PARTS

When replacing any part on this appliance use only spare parts that you can be assured conform to the safety and performance specification that we require. Do not use reconditioned or copy parts that have not been clearly authorised by Ideal. Failure to do so could affect safety or performance of this appliance.

Comprehensive spares parts information and details of approved Ideal Parts Distributors are available on idealheating.com

Our Parts team are also available to help with your Ideal Spare Parts enquiries on 01482 498665.

When calling, and to ensure we can provide you with the most accurate parts information, please ensure you have the following to hand;

- HIU Model
- HIU Serial Number

6. COMMISSIONING

HEAT INTERFACE UNIT COMMISSIONING CHECKLIST

This Commissioning Checklist is to be completed in full by the competent person who commissioned the boiler as a means of demonstrating compliance with the appropriate Building Regulations and then handed to the customer to keep for future reference.

Failure to install and commission according to the manufacturer's instructions and complete this Commissioning Checklist will invalidate the warranty. This does not affect the customer's statutory rights.

Customer Name:										Contact number:														
Address:																								
POD HIU Model:																								
POD HIU Serial Number:																								
Heat Meter Serial Number:																								
Commissioned by (PRINT NAME):															Date:									
Company Name:																								
Company Address:																								
CONTROLS (tick the appropriate boxes)																								
Time and temperature control to heating										Room thermostat and programmer/timer					Programmable room thermostat									
Time and temperature control to hot water										Cylinder thermostat and programmer/timer					HIU intern controls									
Heating zone valves										Fitted					Not required									
Hot water zone valves										Fitted					Not required									
Thermostatic radiator valves										Fitted					Not required									
Automatic bypass to system										Fitted					Not required									
HIU interlock										Fitted					Not required									
ALL SYSTEMS																								
The primary system has been flushed and cleaned in accordance with guidance in CIBSE CP 1.2 before connecting the HIU															Yes									
The domestic heating system has been flushed and cleaned in accordance with BS7593 and the HIU installation instructions															Yes									
What domestic heating system cleaner was used?																								
What domestic heating system inhibitor was used?															Quantity					litres				
Has a domestic heating system filter been installed?															Yes					No				
CENTRAL HEATING MODE measure and record: (for direct appliances record only primary flow / return in central heating mode)																								
Primary differential pressure, between primary flow and return, during central heating operation															kPa									
Primary flow rate					m ³ /hr					Primary operating pressure					bar									
Primary flow temperature					°C					Primary return temperature					°C									
Central heating flow temperature					°C					Central heating return temperature					°C									
DOMESTIC HOT WATER MODE measure and record:																								
Is the installation in a hard water area (above 200ppm)?															Yes					No				
If Yes above, and if required according to the installation manual, has a water scale reducer been fitted?															Yes					No				
What type of scale reducer has been fitted?																								
Primary differential pressure, between primary flow and return, during domestic hot water operation															kPa									
Primary flow rate					m ³ /hr					Primary operating pressure					bar									
Primary flow temperature					°C					Primary return temperature					°C									
Cold water inlet temperature					°C					Domestic hot water temperature					°C									
Hot water has been checked at all outlets?										Yes					Domestic hot water flow rate					l/min				
ALL INSTALLATIONS																								
The heating and hot water systems comply with the appropriate Building Regulations															Yes									
The HIU and associated products have been installed and commissioned in accordance with the manufacturer's instructions															Yes									
The operation of the boiler and system controls have been demonstrated to and understood by the customer															Yes									
The manufacturer's literature, including Commissioning Checklist and Service Record, have been explained and left with the customer															Yes									
Commissioning Engineer's Signature																								
Customer's Signature																								
(To confirm satisfactory demonstration and receipt of the manufacturer's literature)																								

SERVICE RECORD

It is recommended that your HIU and heating system is serviced regularly and that the appropriate Service Interval Record is completed.

Notes for the Service Provider. Before completing the appropriate Service Record below, please ensure that you have carried out the service as described in the manufacturer's instructions. Always use the manufacturer's specified spare part when replacing controls.

SERVICE 01		Date:	
Engineer name:			
Company name:			
Telephone number:			
Primary differential pressure:		kPa	
Primary strainer checked and cleaned as necessary:		Yes	
Primary temperature:	Flow °C	Return °C	
CH Temperature:	Flow °C	Return °C	
CH system filter checked and cleaned (if fitted)		Yes	
CH system expansion vessel pressure checked / adjusted		Yes	
CH system fill pressure checked / adjusted as necessary		Yes	
DHW Cold / Hot temperature:	Flow °C	Return °C	
Signature			

SERVICE 02		Date:	
Engineer name:			
Company name:			
Telephone number:			
Primary differential pressure:		kPa	
Primary strainer checked and cleaned as necessary:		Yes	
Primary temperature:	Flow °C	Return °C	
CH Temperature:	Flow °C	Return °C	
CH system filter checked and cleaned (if fitted)		Yes	
CH system expansion vessel pressure checked / adjusted		Yes	
CH system fill pressure checked / adjusted as necessary		Yes	
DHW Cold / Hot temperature:	Flow °C	Return °C	
Signature			

SERVICE 03		Date:	
Engineer name:			
Company name:			
Telephone number:			
Primary differential pressure:		kPa	
Primary strainer checked and cleaned as necessary:		Yes	
Primary temperature:	Flow °C	Return °C	
CH Temperature:	Flow °C	Return °C	
CH system filter checked and cleaned (if fitted)		Yes	
CH system expansion vessel pressure checked / adjusted		Yes	
CH system fill pressure checked / adjusted as necessary		Yes	
DHW Cold / Hot temperature:	Flow °C	Return °C	
Signature			

SERVICE 04		Date:	
Engineer name:			
Company name:			
Telephone number:			
Primary differential pressure:		kPa	
Primary strainer checked and cleaned as necessary:		Yes	
Primary temperature:	Flow °C	Return °C	
CH Temperature:	Flow °C	Return °C	
CH system filter checked and cleaned (if fitted)		Yes	
CH system expansion vessel pressure checked / adjusted		Yes	
CH system fill pressure checked / adjusted as necessary		Yes	
DHW Cold / Hot temperature:	Flow °C	Return °C	
Signature			

SERVICE 05		Date:	
Engineer name:			
Company name:			
Telephone number:			
Primary differential pressure:		kPa	
Primary strainer checked and cleaned as necessary:		Yes	
Primary temperature:	Flow °C	Return °C	
CH Temperature:	Flow °C	Return °C	
CH system filter checked and cleaned (if fitted)		Yes	
CH system expansion vessel pressure checked / adjusted		Yes	
CH system fill pressure checked / adjusted as necessary		Yes	
DHW Cold / Hot temperature:	Flow °C	Return °C	
Signature			

SERVICE 06		Date:	
Engineer name:			
Company name:			
Telephone number:			
Primary differential pressure:		kPa	
Primary strainer checked and cleaned as necessary:		Yes	
Primary temperature:	Flow °C	Return °C	
CH Temperature:	Flow °C	Return °C	
CH system filter checked and cleaned (if fitted)		Yes	
CH system expansion vessel pressure checked / adjusted		Yes	
CH system fill pressure checked / adjusted as necessary		Yes	
DHW Cold / Hot temperature:	Flow °C	Return °C	
Signature			

SERVICE 07		Date:	
Engineer name:			
Company name:			
Telephone number:			
Primary differential pressure:		kPa	
Primary strainer checked and cleaned as necessary:		Yes	
Primary temperature:	Flow °C	Return °C	
CH Temperature:	Flow °C	Return °C	
CH system filter checked and cleaned (if fitted)		Yes	
CH system expansion vessel pressure checked / adjusted		Yes	
CH system fill pressure checked / adjusted as necessary		Yes	
DHW Cold / Hot temperature:	Flow °C	Return °C	
Signature			

SERVICE 08		Date:	
Engineer name:			
Company name:			
Telephone number:			
Primary differential pressure:		kPa	
Primary strainer checked and cleaned as necessary:		Yes	
Primary temperature:	Flow °C	Return °C	
CH Temperature:	Flow °C	Return °C	
CH system filter checked and cleaned (if fitted)		Yes	
CH system expansion vessel pressure checked / adjusted		Yes	
CH system fill pressure checked / adjusted as necessary		Yes	
DHW Cold / Hot temperature:	Flow °C	Return °C	
Signature			

SERVICE RECORD

It is recommended that your HIU and heating system is serviced regularly and that the appropriate Service Interval Record is completed.

Notes for the Service Provider. Before completing the appropriate Service Record below, please ensure that you have carried out the service as described in the manufacturer's instructions. Always use the manufacturer's specified spare part when replacing controls.

SERVICE 01		Date:	
Engineer name:			
Company name:			
Telephone number:			
Primary differential pressure:			kPa
Primary strainer checked and cleaned as necessary:			Yes <input type="checkbox"/>
Primary temperature:	Flow	°C	Return °C
CH Temperature:	Flow	°C	Return °C
CH system filter checked and cleaned (if fitted)			Yes <input type="checkbox"/>
CH system expansion vessel pressure checked / adjusted			Yes <input type="checkbox"/>
CH system fill pressure checked / adjusted as necessary			Yes <input type="checkbox"/>
DHW Cold / Hot temperature:	Flow	°C	Return °C
Signature			

SERVICE 02		Date:	
Engineer name:			
Company name:			
Telephone number:			
Primary differential pressure:			kPa
Primary strainer checked and cleaned as necessary:			Yes <input type="checkbox"/>
Primary temperature:	Flow	°C	Return °C
CH Temperature:	Flow	°C	Return °C
CH system filter checked and cleaned (if fitted)			Yes <input type="checkbox"/>
CH system expansion vessel pressure checked / adjusted			Yes <input type="checkbox"/>
CH system fill pressure checked / adjusted as necessary			Yes <input type="checkbox"/>
DHW Cold / Hot temperature:	Flow	°C	Return °C
Signature			

SERVICE 03		Date:	
Engineer name:			
Company name:			
Telephone number:			
Primary differential pressure:			kPa
Primary strainer checked and cleaned as necessary:			Yes <input type="checkbox"/>
Primary temperature:	Flow	°C	Return °C
CH Temperature:	Flow	°C	Return °C
CH system filter checked and cleaned (if fitted)			Yes <input type="checkbox"/>
CH system expansion vessel pressure checked / adjusted			Yes <input type="checkbox"/>
CH system fill pressure checked / adjusted as necessary			Yes <input type="checkbox"/>
DHW Cold / Hot temperature:	Flow	°C	Return °C
Signature			

SERVICE 04		Date:	
Engineer name:			
Company name:			
Telephone number:			
Primary differential pressure:			kPa
Primary strainer checked and cleaned as necessary:			Yes <input type="checkbox"/>
Primary temperature:	Flow	°C	Return °C
CH Temperature:	Flow	°C	Return °C
CH system filter checked and cleaned (if fitted)			Yes <input type="checkbox"/>
CH system expansion vessel pressure checked / adjusted			Yes <input type="checkbox"/>
CH system fill pressure checked / adjusted as necessary			Yes <input type="checkbox"/>
DHW Cold / Hot temperature:	Flow	°C	Return °C
Signature			

SERVICE 05		Date:	
Engineer name:			
Company name:			
Telephone number:			
Primary differential pressure:			kPa
Primary strainer checked and cleaned as necessary:			Yes <input type="checkbox"/>
Primary temperature:	Flow	°C	Return °C
CH Temperature:	Flow	°C	Return °C
CH system filter checked and cleaned (if fitted)			Yes <input type="checkbox"/>
CH system expansion vessel pressure checked / adjusted			Yes <input type="checkbox"/>
CH system fill pressure checked / adjusted as necessary			Yes <input type="checkbox"/>
DHW Cold / Hot temperature:	Flow	°C	Return °C
Signature			

SERVICE 06		Date:	
Engineer name:			
Company name:			
Telephone number:			
Primary differential pressure:			kPa
Primary strainer checked and cleaned as necessary:			Yes <input type="checkbox"/>
Primary temperature:	Flow	°C	Return °C
CH Temperature:	Flow	°C	Return °C
CH system filter checked and cleaned (if fitted)			Yes <input type="checkbox"/>
CH system expansion vessel pressure checked / adjusted			Yes <input type="checkbox"/>
CH system fill pressure checked / adjusted as necessary			Yes <input type="checkbox"/>
DHW Cold / Hot temperature:	Flow	°C	Return °C
Signature			

SERVICE 07		Date:	
Engineer name:			
Company name:			
Telephone number:			
Primary differential pressure:			kPa
Primary strainer checked and cleaned as necessary:			Yes <input type="checkbox"/>
Primary temperature:	Flow	°C	Return °C
CH Temperature:	Flow	°C	Return °C
CH system filter checked and cleaned (if fitted)			Yes <input type="checkbox"/>
CH system expansion vessel pressure checked / adjusted			Yes <input type="checkbox"/>
CH system fill pressure checked / adjusted as necessary			Yes <input type="checkbox"/>
DHW Cold / Hot temperature:	Flow	°C	Return °C
Signature			

SERVICE 08		Date:	
Engineer name:			
Company name:			
Telephone number:			
Primary differential pressure:			kPa
Primary strainer checked and cleaned as necessary:			Yes <input type="checkbox"/>
Primary temperature:	Flow	°C	Return °C
CH Temperature:	Flow	°C	Return °C
CH system filter checked and cleaned (if fitted)			Yes <input type="checkbox"/>
CH system expansion vessel pressure checked / adjusted			Yes <input type="checkbox"/>
CH system fill pressure checked / adjusted as necessary			Yes <input type="checkbox"/>
DHW Cold / Hot temperature:	Flow	°C	Return °C
Signature			



At Ideal Heating we take our environmental impact seriously, therefore when installing any Ideal Heating product please make sure to dispose of any previous appliance in an environmentally conscious manner. Households can contact their local authority to find out how. See <https://www.gov.uk/managing-your-waste-an-overview> for guidance on how to efficiently recycle your business waste.

Technical Training

Our Expert Academy offer a range of training options designed and delivered by our experts in heating. For details please visit: expert-academy.co.uk

Ideal Boilers Ltd., pursues a policy of continuing improvement in the design and performance of its products. The right is therefore reserved to vary specification without notice.

Ideal is a trademark of Ideal Heating.

Registered Office

Ideal Boilers Ltd., National Avenue, Hull, East Yorkshire, HU5 4JB

Tel 01482 492251 Fax 01482 448858

Registration No. London 322 137

EU Authorised Representative:

Atlantic SFDT

44 Boulevard des Etats-Unis, 85 000 La Roche-Sur-Yon, France

+33 (0)2 51 44 34 34

Ideal Technical Helpline: 01482 498663

Ideal Consumer Helpline: 01482 498660

Ideal Parts: 01482 498665

idealheating.com

ideal
HEATING