

ideal
HEATING

COMMERCIAL

VICEROY

GTS9 - GTS14



Minimal Emissions



Easy to Install



Compact Size



Floor Standing

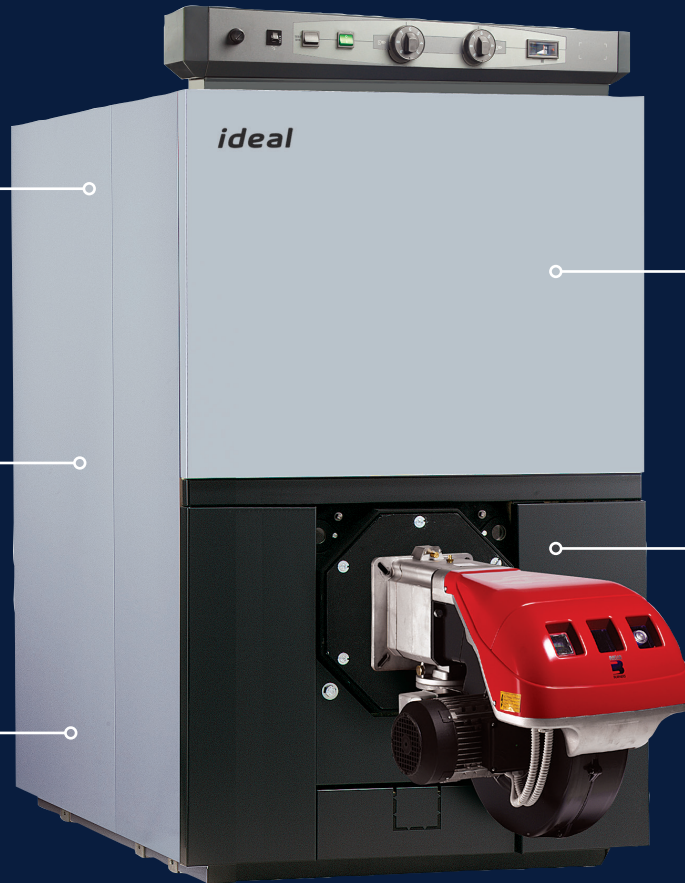

Features & specification

Viceroy GTS boilers are a range of cast iron sectional pressure jet boilers offering high efficiency operation, ease of maintenance, fuel flexibility and low emissions. Suitable for oil or gas operation the Viceroy GTS range is supplied in a choice of 7 standard models, rated in outputs from 450 kW to 780 kW and has a maximum operating pressure of 6 bar. All models have high/low operation. Designed with a large combustion chamber, 3 pass horizontal flue ways, incorporating fins and cast iron turbulators, the Viceroy GTS ensures maximum heat transfer efficiency.

- High efficiency (full and part load)
- Minimal emissions
- 3 pass cast iron heat exchanger
- Compact size
- Easy to install and service
- Minimum return temperature 30°C
- Gas fired, oil fired or dual fuel
- Site assembly
- Left or right hinged burner door
- Available as boiler body only

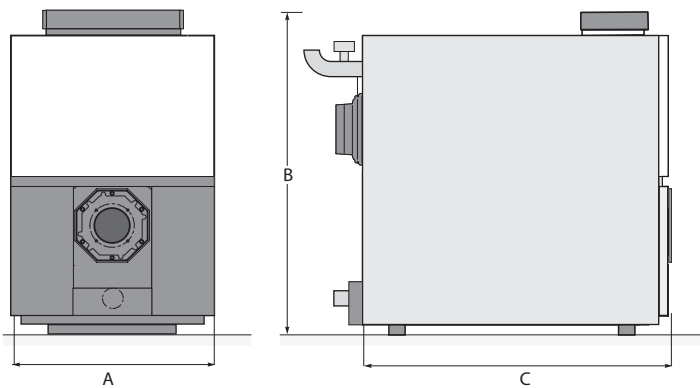

BOILER	DIM A	DIM B	DIM C
GTS 9	1000	1605	1687
GTS 10	1000	1605	1847
GTS 11	1000	1605	2007
GTS 12	1000	1605	2167
GTS 13	1000	1605	2327
GTS 14	1000	1605	2487

DIMENSIONS & CLEARANCES

The following minimum clearances must be maintained for operation and servicing:

- ↑ TOP: 700mm
- ↔ SIDES: 500MM
- ↓ REAR: 1000MM
- FRONT: 2000-2500MM

VICEROY GTS9 - GTS14

TECHNICAL SPECIFICATIONS

MODEL		GTS 9	GTS 10	GTS 11	GTS 12	GTS 13	GTS 14
No. of Sections		9	10	11	12	13	14
Maximum Heat Output	kW	450	540	600	670	720	780
Minimum Heat Output	kW	390	450	540	600	670	720
Boiler Water Content	l	409	452	495	538	581	624
Hydraulic Resistance at 11K	mbar	49.3	75.9	84.2	104.9	127.9	161.4
	in.w.g	19.7	30.3	33.7	42.0	51.2	64.6
Hydraulic Resistance at 20K	mbar	14.9	23.0	25.5	31.7	38.7	48.8
Combustion Chamber Resistance (at zero draught)	mbar	1.5	2	2.5	2.5	2.5	3.5
Boiler DRY Weight Less Burner Unit	kg	2072	2238	2454	2638	2880	3057
Flue Size	mm	250	250	300	300	300	300
Maximum Flow Temperature	°C	90	90	90	90	90	9

GAS FIRING DATA

Maximum Gas Rate	m ³ /h	51.74	61.88	69.06	77.11	82.87	89.77
Maximum Flue Gas Volume	m ³ /sec	0.32	0.39	0.43	0.48	0.52	0.56
Maximum Flue Gas Temperature at 9.5% CO ₂	°C	220	220	220	220	220	220
Seasonal Efficiency	%	82.88	84.17	83.30	83.81	83.81	83.59

OIL FIRING DATA

Maximum Oil Rate	l/h	49.76	59.51	66.42	74.17	79.71	86.35
	gal/h	10.95	13.09	14.61	16.32	17.54	19.0
Maximum Flue Gas Volume	m ³ /sec	0.29	0.35	0.39	0.43	0.47	0.50
	ft ³ /min	614	737	820	915	985	1065
Maximum Flue Gas Temperature at 13% CO ₂	°C	220	220	220	220	220	220
Seasonal Efficiency	%	86.20	87.50	86.60	87.20	87.20	86.90

MINIMUM FLOW RATES

Normal Water Flow Rate Temperature Difference 11°C (20°F)	l/s	9.77	11.73	13.03	14.55	15.63	16.94
Minimum Water Flow Rate Temperature Difference 35°C (63°F)	l/s	3.07	3.69	4.09	4.57	4.91	5.32

CONVERSIONS RATE

• 1 kW = 3412 Btu/h	• 1m ³ /h = 35.315 ft ³ /h
• 1 litre = 0.22 gallons	• 1m ³ /sec = 2120 ft ³ /min
• 1 mbar = 0.4 in.w.g.	• 1l/h = 0.220 gal/h
• 1 kg = 2.2 lb	• 1l/s = 13.198 gal/min

*1 year warranty subject to Terms and Conditions.

GET A QUOTE

idealheating.com |     