

# EVOJET

1750kW



BIM



Pressure jet



Dual fuel



Floor standing



Part L



# Features and specification

The Evojet condensing range of pressure jet boilers are available in 14 models with outputs from 150-3000kW. Floor standing boilers for applications in either single or multiple configurations.

- Up to 109.3% part load efficiency
- Designed to operate up to 40°C ΔT providing minimum flow rates are achieved
- Dedicated low temp return
- Stainless steel heat exchanger
- Triple flue pass for high operating efficiencies
- Multiple burner options available (see page 3 for details)
- Modulation via 0-10 volt BMS, or RWF controller

## DIMENSIONS AND CLEARANCES

BOILER	WIDTH (A)	DEPTH (B)	HEIGHT (C)
1750	1800	3620	1945

The following minimum clearances must be maintained for operation and servicing:

➔ FRONT: **BURNER LENGTH + 600MM (FOR ACCESS / MAINTENANCE)**  
**BOILER LENGTH (FOR CLEANING)**

↓ REAR: **1000mm (Min)**

↔ SIDES: **1500mm (Min)**

↑ TOP: **1000mm (Min)**

## BOILER ASSEMBLY

Exploded view

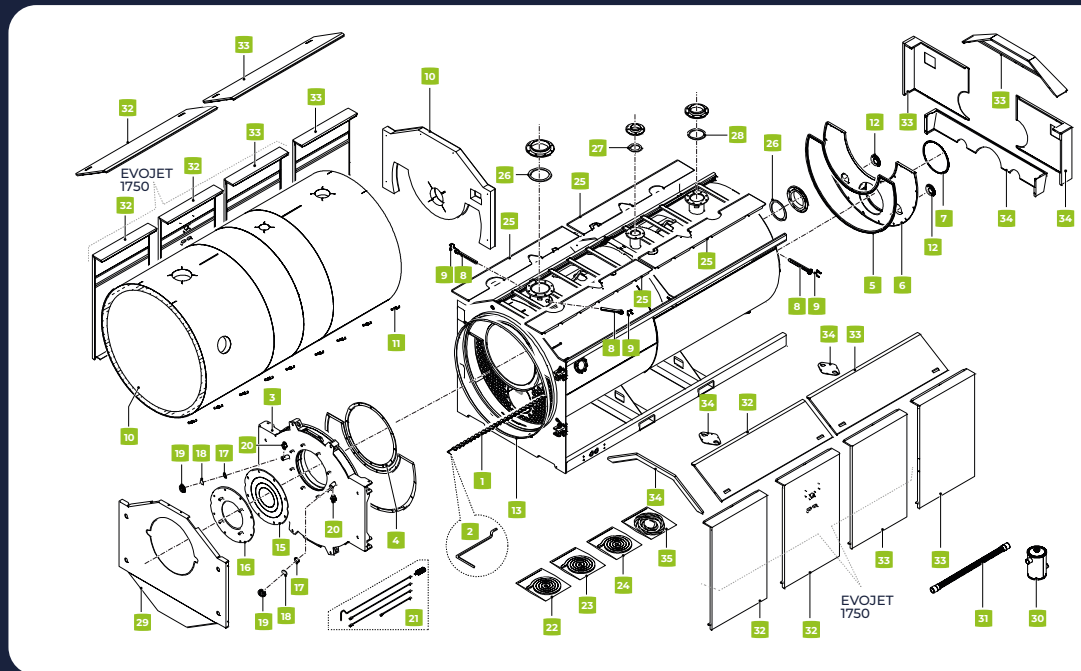

### KEY

- |                        |                   |                        |                              |
|------------------------|-------------------|------------------------|------------------------------|
| 1. Diffuser            | 10. Protection    | 19. Ring               | 28. Washer                   |
| 2. Hook                | 11. Spring        | 20. Test point         | 29. Front panel              |
| 3. Door                | 12. Cover         | 21. Flue brush         | 30. Sifon                    |
| 4. Plait               | 13. Plait         | 22. Mattress           | 31. Condensation outlet pipe |
| 5. Washer              | 14. -             | 23. Mattress           | 32. Panelling assembly       |
| 6. Fumes chamber       | 15. Flange seal   | 24. Plait              | 33. Panelling assembly       |
| 7. Washer              | 16. Burner flange | 25. Panelling assembly | 34. Panelling assembly       |
| 8. Probe holder pocket | 17. Washer        | 26. Flange seal        | 35. Plait                    |
| 9. Spring              | 18. Glass         | 27. Washer             |                              |

# EVOJET 1750kW

## TECHNICAL SPECIFICATIONS

### GENERAL

Dry weight	KG	3985
Boiler dimensions	mm	1945 (H) x 1800 (W) x 3620 (D)
Boiler clearances	mm	Front (maintain): Burner Length + 600mm Front (clean): Boiler Length Left Side: 1500 Right Side: 1500 Rear: 1000 Top: 1000
Full load efficiency NCV (80/60)	%	98.2
Part load efficiency NCV (50/30)	%	108.7
Seasonal efficiency GCV (Part L vol.2 2022)	%	96.0
Min gas pressure (Nat Gas)	mbar	20*

Burner and Gas Train selections for Natural Gas applications are based on standard design requirements (as stated in IGE/UP/2) of 20mbar gas pressure available at the appliance under max flow conditions. If this pressure is not available, or the available gas pressure is higher, or for alternative fuel types - please consult your sales contact for alternative matching.

Certain burner types will require a higher MINIMUM GAS PRESSURE and an additional gas booster kit will be necessary. Confirm with your sales contact.

### HYDRAULICS

Pressure drop $\Delta T$ 10°C	mbar	40.0
Pressure drop $\Delta T$ 20°C	mbar	16.0
Nominal flow rate $\Delta t$ 10°C	l/sec	41.81
Nominal flow rate $\Delta t$ 20°C	l/sec	20.90
Min flow rate	l/sec	5.67
Min flow temperature	°C	30
Max flow temperature	°C	90
High limit set point	°C	100
Max working pressure	bar	6
Condensate connection	inches	1.25
Flow connection	DN	DN150 PN6
Return connection (lt)	DN	DN150 PN6
Return connection (ht)	DN	DN100 PN6
Safety valve connection	DN / Ø"	DN80 PN6
Water content	litres	3060

### BURNER (Low NOx)

Fuel	(Type G20)	Natural Gas
Fuel consumption (Nat Gas)	m <sup>3</sup> /h	181.0
Boiler output (mean 70°C)	kW	1718.5
Boiler output (mean 40°C)	kW	1863.8
Boiler input (GCV)	kW	1943.0
NO <sub>x</sub> (GCV EN676)	mg/kWh	61
NO <sub>x</sub> (at 3% O <sub>2</sub> dry flue gas reference)	mg/Nm <sup>3</sup>	65
Furnace pressure	mbar	8.4
Furnace volume	dm <sup>3</sup>	1593.0
Min burner length	mm	350
Burner hole diameter	mm	520

### FLUE/AIR INLET

Flue size	mm	400
Max flue gas mass airflow rate	kg/sec	0.7500
Min-max flue gas temperature	°C	<45 - 75**

\*\* Dependent on return temperature.

### ELECTRICAL (PRIMETECH CONTROL PANEL)

Electrical supply	230 ± 10% 50Hz 1 Ph	
Current (max no pump)	amp	6.3
Power consumption	watt	250
Fuse rating	amp	6.3T
Insulation class IP	X4D	

### CONTROL/BOILER/BURNER OPERATION

0-10V DC BMS or Siemens RWF	Optional
High limit protection	Standard
Boiler temperature gauge	Standard
Control thermostat sensor	Standard
Safety thermostat sensor	Standard
Two stage thermostat	Yes

### BURNER MATCHING OPTIONS

NG	Yes
LPG	Yes*
Pre-mix	Yes
Oil	Yes
Dual fuel	No

Modulating and Low NOx options available; please contact us for full details. Oil burners would be subject to confirmation that the fuel supply was a suitable type / grade.

\* Burner matching for LPG operation by special request.

GET A QUOTE    

[idealheating.com](http://idealheating.com) | 01482 492251 | [commercial@idealheating.com](mailto:commercial@idealheating.com)

## SUGGESTED ENGINEERING SPECIFICATION

The Suggested Engineering Specification is wording designed for specifiers to copy and paste into their specifications to ensure inclusion of Ideal Heating commercial boilers.

### OVERVIEW

The boiler must be a fully automatically controlled, floor standing condensing boiler with a triple flue pass stainless steel heat exchanger. While they are designed primarily for central heating purposes, in conjunction with a suitable storage cylinder they can also be used to produce domestic hot water on an indirect fully pumped sealed water system.

All parts that come into contact with the combustion gases are made from titanium stabilised stainless steel to ensure maximum resistance to the corrosive action of acid condensation.

The boiler must incorporate two return water connections to facilitate multiple applications e.g. CH & DHW and enables the optimum operating efficiency to be achieved.

The boilers must be designed to operate with **Natural Gas, LPG or Oil** (delete as required) using pressure-jet or premixed burners. The burner specification will enable the choice of 2-stage, Modulating, Low NOx and Ultra Low NOx operation.

### CONTROLS

The boiler control options must be selected at the time of purchase:

- Two stage burner
- Modulating burner
- BMS 0-10V
- Oil & dual fuel

The boiler must include control features enabling set point adjustment, heating circuit control of one constant temperature, one variable temperature and one DHW circuit and safety lock out parameters including fault diagnosis for both boiler and external components such as sensors or pumps.

Boiler capabilities must include, with the use of external components, frost protection, weather or room compensation and system pump control.

### FLUE

The condensing boilers must be suitable for use with an open flued application in B23 configuration. The B23P configuration can only be used with a premix gas burner.

### HYDRAULIC

The condensing boiler must be suitable for connection to a fully pumped sealed water system. All hydraulic connections including flow return and condensate drain must be located on the bottom or rear of the boiler. The boiler must have a maximum operating pressure of 6 bar and be suitable for heating and indirect hot water systems.

### DIMENSIONS

The condensing boiler must fit within maximum permitted floor space of 0.97m<sup>2</sup> (150 and 210kW models)/1.23m<sup>2</sup> (270 and 350kW models)/1.47m<sup>2</sup> (450 and 900kW models)/2.03m<sup>2</sup> (800 and 1000kW models)/2.40m<sup>2</sup> (1250kW model)/2.67m<sup>2</sup> (1450kW model)/6.34m<sup>2</sup> (1750kW model)/7.04m<sup>2</sup> (2100kW model)/8.19m<sup>2</sup> (2700kW model)/9.00m<sup>2</sup> (3000kW model).

### MOUNTING / POSITIONING

The condensing boilers will be floor standing.

### EFFICIENCY

The condensing boilers are capable of high seasonal efficiencies with a minimum requirement of 95.8% (Part L Vol.2 2022) and low NOx emissions between 43 - 65mg/kWh (47 - 70mg/Nm<sup>3</sup>) depending on boiler model, using Low NOx Natural Gas burner.

### APPROVALS

The manufacturer must be ISO 9001 accredited

### SPECIFICATION

The boiler must be capable of the below flow rates:

BOILER MODEL	MIN FLOW (L/H)
150	1,700
210	2,400
270	3,100
350	4,000
450	5,100
600	6,800
800	9,100
1000	11,400
1250	14,200
1450	16,500
1750	20,400
2100	24,500
2600	30,400
3000	35,000

### WARRANTY

The boiler must be available with a 2 year warranty.

Please note that the above information is correct at time of publication. Ideal Heating pursues a policy of continuous improvement in design and performance of its products and reserves the right to vary specification without notice.