

ECOMOD

Commercial Heat Pumps

From the **UK's leading**
commercial heating
manufacturer



SCAN ME



Visit our website for more details
[idealheating.com/commercial-heat-pumps](https://www.idealheating.com/commercial-heat-pumps)

CONTENTS

03	THE ECOMOD RANGE OF AIR SOURCE HEAT PUMPS	16	ECOMOD 290HT COEFFICIENT OF PERFORMANCE (COP) GRAPHS	32	ECOMOD COEFFICIENT OF PERFORMANCE (COP) GRAPHS
04	JOIN THE NET ZERO JOURNEY	18	ECOMOD CO2Q & CO2 NATURAL REFRIGERANT HEAT PUMPS	34	BUFFER TANKS
05	HOW A HEAT PUMP WORKS	21	ECOMOD CO2Q & CO2 TECHNICAL SPECIFICATIONS	36	FUNCTIONAL DIAGRAM
06	UNDERSTANDING REFRIGERANTS & THE EFFECTS ON PERFORMANCE	23	ECOMOD CO2Q & CO2 SUGGESTED ENGINEERING SPECIFICATION	37	SCHEMATICS
08	COP AND SCOP MEASURES OF EFFICIENCY	24	ECOMOD CO2Q & CO2 COEFFICIENT OF PERFORMANCE (COP) GRAPHS	44	CREATING A LOW CARBON HYBRID HEATING SYSTEM
09	SOUND POWER AND SOUND PRESSURE	26	ECOMOD RANGE COMMERCIAL HEAT PUMPS	46	TRAINING AND AFTERSALES SUPPORT
10	ECOMOD 290HT NATURAL REFRIGERANT HEAT PUMPS	29	ECOMOD - TECHNICAL SPECIFICATIONS		
13	ECOMOD 290HT TECHNICAL SPECIFICATIONS	31	ECOMOD - SUGGESTED ENGINEERING SPECIFICATION		
15	ECOMOD 290HT SUGGESTED ENGINEERING SPECIFICATION				

THE **ECOMOD** RANGE OF AIR SOURCE HEAT PUMPS

IDEAL HEATING IS THE UK'S MARKET LEADER OF HIGH EFFICIENCY COMMERCIAL HEATING SOLUTIONS

WITH OVER 100 YEARS OF EXPERIENCE AND KNOWLEDGE, WE HAVE A TRACK RECORD OF DEVELOPING MARKET LEADING HEATING SOLUTIONS FOR COMMERCIAL PROPERTIES.

We have led the way in commercial heating by ensuring our heating products are at the forefront of technology, quality and design by delivering both high efficiency and low running costs.

Now, we have taken the next step forward by introducing our new **ECOMOD natural refrigerant commercial heat pumps**.

Featuring R290 and CO2 refrigerant for ultra-low GWP they are able to achieve high temperatures up to 75°C. These innovative heat pumps will ensure our customers have the best and most advanced solutions for heating and hot water, while helping businesses in the UK on their journey to Net Zero.

Our original ECOMOD heat pump is still available and features R32 refrigerant.

JOIN THE
NET ZERO
JOURNEY



JOIN THE NET ZERO JOURNEY

THE UK IS LEGALLY COMMITTED TO ACHIEVING NET ZERO BY 2050. AROUND 20% OF OUR EMISSIONS - AND 40% OF OUR ENERGY CONSUMPTION - ARE ATTRIBUTED TO HEATING AND HOT WATER FOR BUILDINGS. DECARBONISING THESE IS CRITICAL.

Join the Net Zero Journey is Ideal Heating's strategy to provide customers with low carbon commercial heating solutions to help deliver us all to Net Zero. We have the knowledge, experience and skills to provide customers with heating and hot water solutions to meet their specific needs and requirements.



REGULATIONS DRIVING CHANGE

The uplift to Building Regulations Approved Document L, Conservation of fuel and power in 2022 is the beginning of our transition towards a decarbonised future, paving the way to net zero. Just around the corner, in 2025, the Future Buildings Standard is set to come into effect, with the aim of producing highly efficient non-domestic buildings which use low-carbon heat and have the best fabric standards possible.

Want to know more about how Ideal Heating can assist in your transition to low carbon heating?

Visit our new Net Zero website page: idealcommercialheating.com/net-zero



“Heat pumps are a widely suitable and cost-effective solution for decarbonising the UK’s buildings and are vital to delivering Net Zero” states the UK government¹.

That’s because heat pumps reduce the reliance on fossil fuels, produce zero local carbon emissions, and can be up to 400% more efficient than traditional boilers.

Heat pumps utilise the free energy in the air to heat water, even when that air temperature is as low as -20°C. When heat pumps are partnered with a renewable electricity supplier, heat generation is 100% carbon neutral.

HOW A HEAT PUMP WORKS

THE TECHNOLOGY: HEAT PUMP CYCLE

Heat pumps are a highly efficient, eco-friendly way of producing heat for commercial buildings. By taking ‘free energy’ from the air via a refrigerant cycle they generate heat without releasing any carbon emissions.

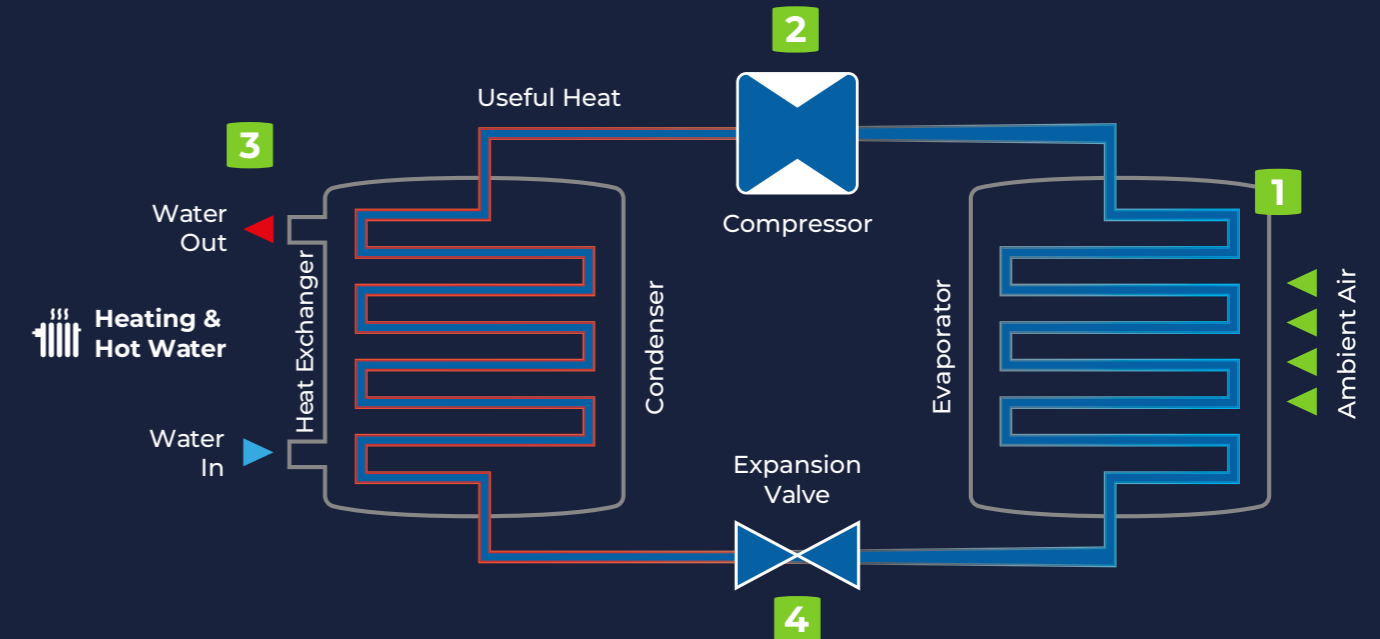

1. CAPTURE

The fan passes ambient air over extremely cold liquid refrigerant. The refrigerant captures the heat from the ambient air and becomes a warm vapour.

2. COMPRESS

The warm refrigerant vapour passes through a compressor which produces hot refrigerant and usable heat.

3. EXCHANGE

The heat in the hot refrigerant is then transferred to the heating and hot water through a heat exchange.

4. EXPAND

As the heat is transferred the refrigerant passes through an expansion valve which reduces its temperature, making it really cold again and enabling it to capture heat from the ambient air, continuing the cycle.

Air source heat pumps gather heat energy from the surrounding air, which, via a heat exchanger, is transferred into the heat pump refrigerant and turned into vapour. This vapour is then passed through a compressor and turned into a high-pressure, high-temperature refrigerant, raising the temperature to a point that can deliver heat throughout a building's heating system. The refrigerant is the working liquid used within the heat pump and refrigerant types are now broadly split into two categories: HFCs (Hydrofluorocarbon) such as R32 and natural refrigerants, which include R290 and CO2.

¹ Heat Pump Investment Roadmap, Leading the way to net zero, April 2023

UNDERSTANDING REFRIGERANTS & THE EFFECTS ON PERFORMANCE

HEAT PUMPS ARE BASED ON TRIED AND TESTED TECHNOLOGY, BUT THE REFRIGERANT USED IN MANY OLDER MODELS - AND EVEN SOME STILL BEING MARKETED TODAY - HAVE A HIGH GLOBAL WARMING POTENTIAL (GWP). REFRIGERANTS WITH A HIGH GWP CONTAIN EXTREMELY POTENT GREENHOUSE GASES, THAT WARM THE PLANET.

HOW DOES THE REFRIGERANT AFFECT THE HEAT PUMP SYSTEM PERFORMANCE?

When designing a heat pump system you need to balance the performance of the heating system with the performance of the refrigerant.

There are key areas to consider when choosing the right heat pump for the system:

- **Max flow temperature** - not all refrigerants can generate sufficient domestic hot water temperatures or heating outputs
- **Global Warming Potential** - different refrigerants have a different Global Warming Potential (GWP). The lower the GWP, the more eco-friendly it is and therefore better for the environment
- **Coefficient of Performance** - the heat output affects the coefficient of performance (COP) of the heat pump
- **Ambient Air Temperature** - the heat pump performance will be affected also by the ambient air temperature. The air has heat (energy) in it which is extracted by the heat pump and raising with the help of the refrigerant within. The warmer the air at the start of the cycle, the more energy that can be extracted. If the air temperature drops, then the heat pump has to work harder to extract more energy using more electricity.

The new ECOMOD heat pumps use natural refrigerant with an ultra-low GWP. Moving to natural refrigerants which have a low GWP is not only good for the planet, but also makes commercial sense as high GWP refrigerants become increasingly scarce and therefore more expensive. Using heat pumps which use natural refrigerant helps future proof your investment.

The new ECOMOD heat pumps use natural refrigerant with an ultra-low GWP:

MODELS	REFRIGERANT	GWP	OUTPUTS
ECOMOD 290HT	R290 (PROPANE)	3	15 – 50KW
ECOMOD CO2 & CO2Q	R744 (CO2)	1	65 – 130KW

The lower the Global Warming Potential (GWP) - the more eco-friendly it is and therefore better for the environment.

Refrigerant Name	Trade Name	Chemical Name	Ozone Depletion Potential	Gwp-Global Warming Potential	Differences	Normal Flow Temp °C
R744	Carbon Dioxide	CO2	0	1	Natural refrigerant with ultra-low GWP, very eco-friendly and non-flammable.	70-90
R290	Propane	Propane	0	3	Natural refrigerant with ultra-low GWP, very eco-friendly and highly flammable.	75
R454c	HFO	Opteon XL20	0	148	Deposits of TFA do not degrade in water	65
R454b	HFC	Difluoromethane	0	466	R410a replacement but unlike R410a is a synthetic refrigerant and not a single component refrigerant.	55
R32	HFC-32	Difluoromethane	0	675	Lower GWP, eco-friendly, mildly flammable, lower cost, currently most popular refrigerant choice.	55
R134a	HFC-134a	1,1,1,2-Tetrafluoroethane	0	1430	Being phased out, as of January 2022.	45
R407c	Klea66	R32/R125/R134a	0	1774	Still used but will be phased out in 2025 in systems with less than 3kg charge.	65
R410a	Puron, AZ-20	R-32/R-125 (50/50)	0	2088	Slowly being phased out, higher GWP, worse for environment, non-flammable, higher costs.	60



COP AND SCOP MEASURES OF EFFICIENCY

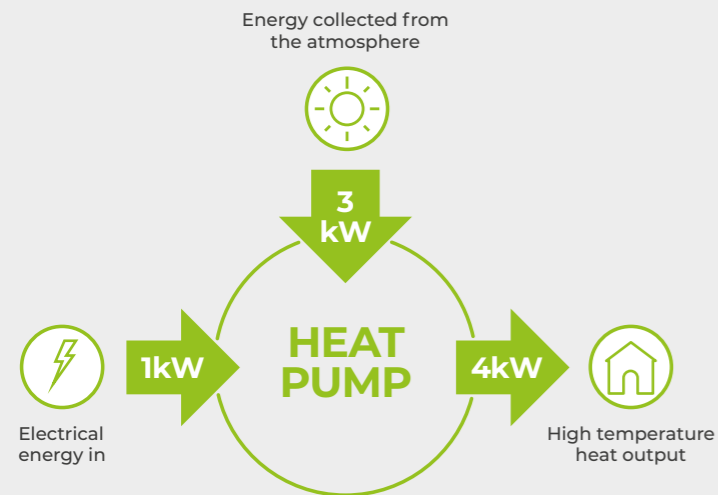

COP - COEFFICIENT OF PERFORMANCE

The coefficient of performance (COP) refers to the efficiency of a heat pump and directly relates to the energy the output from a heat pump. It is the ratio of heat produced, relative to each unit of electricity consumed in the heat pump.

$$\text{COP} = \frac{\text{Heat output}}{\text{Electrical Input}}$$

See product range sections for COP graphs

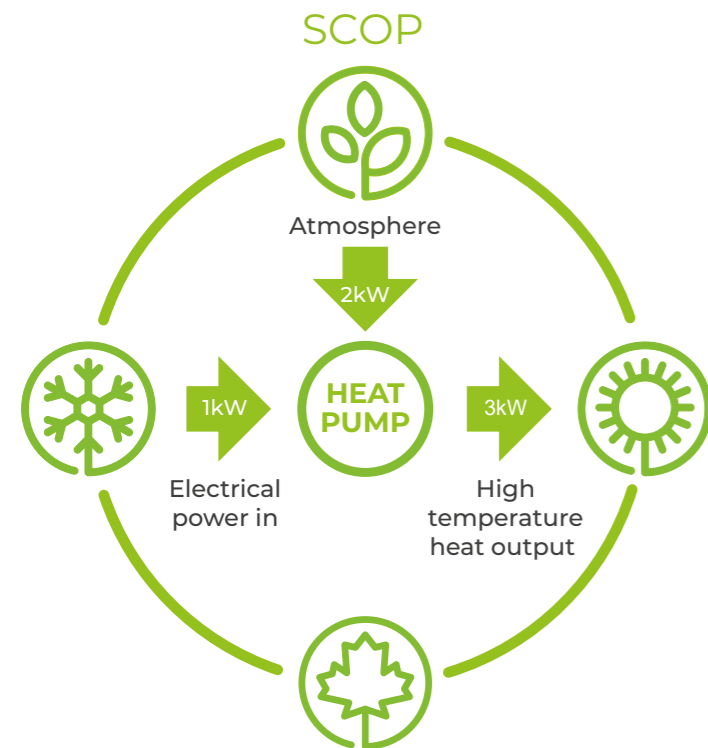

SCOP - SEASONAL COEFFICIENT OF PERFORMANCE

The seasonal coefficient of performance (SCOP) is the average COP carried over the annual heating season (the full year).

SOUND POWER AND SOUND PRESSURE

THE LEVELS OF NOISE THAT A HEAT PUMP EMITS IS REPRESENTED AS A SOUND POWER AND SOUND PRESSURE LEVEL

SOUND POWER

Sound power is a property of the product components under laboratory testing.

The sound power is the sound waves emitted from a source (heat pump is the source in this case), it is measured in decibels (dB). The sound power is the total sound emitted from the source.

SOUND PRESSURE

The sound pressure is sometimes referred to as the 'noise level'. This describes the disturbance of sound and what we realistically hear.

SOUND POWER LEVELS

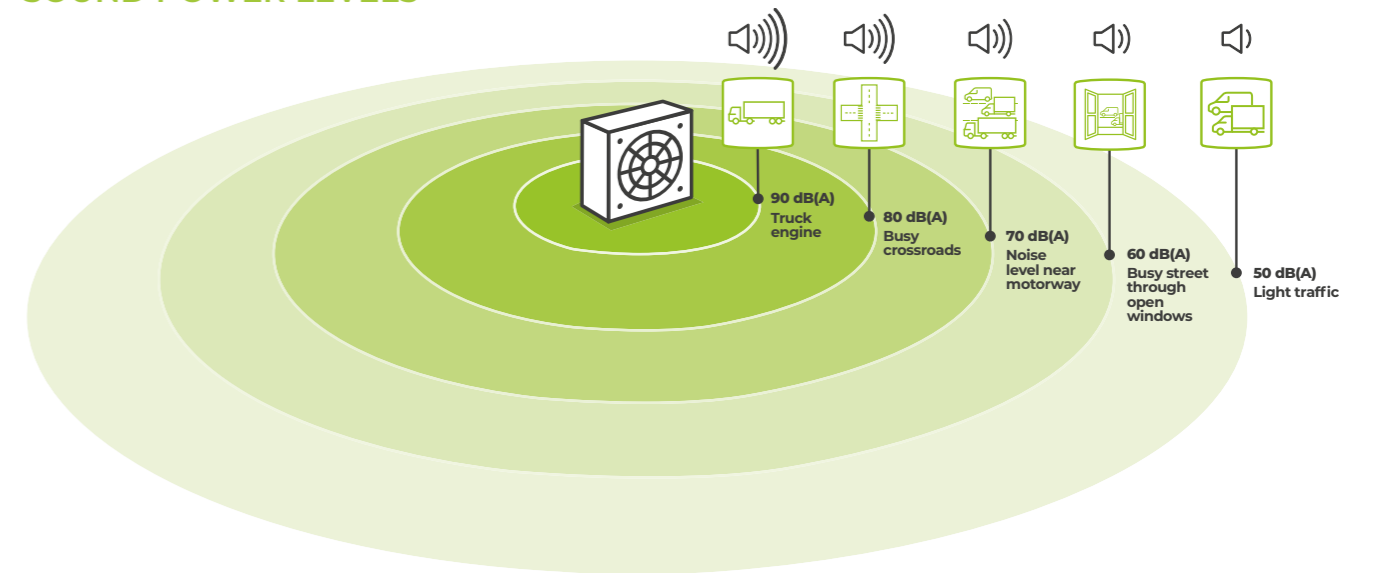

SOUND POWER DATA OUTDOOR UNIT

ECOMOD 290HT				ECOMOD CO2Q			ECOMOD CO2			ECOMOD				
15kW & 18kW	27kW	40kW	50kW	65kW	95kW	130kW	65kW	95kW	130kW	14kW & 18kW	26kW	32kW	50kW	70kW
64	65	82	83	71	72	72	74	74	75	68	74	76	82	83

ECOMOD 290HT NATURAL REFRIGERANT HEAT PUMPS

15kW, 18kW, 27kW, 40kW & 50kW

DESIGNED WITH COMMERCIAL BUILDINGS IN MIND THESE NATURAL REFRIGERANT MONOBLOC AIR SOURCE HEAT PUMPS CAN BE EASILY CASCADED TO ACHIEVE THE HIGHER OUTPUTS NEEDED FOR COMMERCIAL INSTALLATIONS.



High temperature up to 75°C



Suitable for commercial properties



Ultra-low GWP



Quiet noise level as low as 64dB(A)**



Highly efficient: COP up to 4.94***



The **ECOMOD 290HT** range of monobloc air source heat pumps are available in 3 chassis sizes and 5 outputs: **15kW, 18kW, 27kW, 40kW** and **50kW**.

Natural refrigerant monobloc air source heat pumps with ultra-low global warming potential of 3 due to the use of R290 refrigerant.

Able to achieve high temperatures up to 75°C.

NATURAL REFRIGERANTS

Use of natural refrigerant helps future proof your investment. Heat pumps using traditional refrigerants could potentially become obsolete due to any changes to F-Gas regulations.



15 & 18kW

40 & 50kW

27kW

Monobloc air source heat pumps with ultra-low global warming potential due to the use of R290 refrigerant.
High temperatures up to 75°C.

ECOMOD 290HT HEAT PUMPS

FEATURES & SPECIFICATION

- Free commissioning
- Monobloc air source heat pump
- High temp up to 75°C
- Single unit with the refrigeration cycle contained within the outdoor unit
- Inverter controlled compressor to accurately match the heat demand
- Ultra-low global warming potential of 3 due to the use of R290 refrigerant
- Quiet noise level as low as 64dB(A)**
- Highly efficient with coefficient of performance (COP) rating up to 4.94
- Suited to larger installations - cascade systems to achieve higher output
- 2-year warranty (extended to 5 years if commissioned by Ideal Heating)*
- Combine with Ideal industry leading boilers for a hybrid heating system

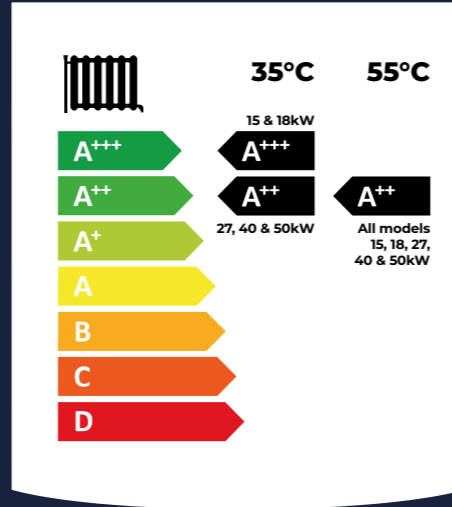

ACCESSORIES & OPTIONS

	INCLUDED	REQUIRED
Integral controller - 40kW & 50kW	✓	
External control unit - 15kW, 18kW, 27kW	✓	
Flexible hoses		✓
Anti-vibration rubber feet		✓
Exogel antifreeze kit		✓

INSTALLATION CLEARANCES

15, 18 & 27kW						
FRONT	REAR	LEFT	RIGHT	TOP	BOTTOM	
1500	400	400	500	1500	50	
40 & 50kW						
FRONT	REAR	LEFT	RIGHT	TOP	BOTTOM	
1500	1500	1200	1000	1500	50	

Side clearance of 1000mm (15,18 & 27kW) and 2200mm (40 & 50kW) when used in cascade. The outdoor unit must be raised by at least 50mm from the ground. All measurements in mm unless otherwise stated.



BIM objects available to download at: idealcommercialheating.com/bim

TECHNICAL SPECIFICATIONS



ECOMOD 290HT

		15kW	18kW	27kW	40kW	50kW
Heat Pump Space Heating [35°C]	ErP rating	A+++	A+++	A++	A++	A++
	SCOP	5.02	4.99	4.46	4.09	4.2
Heat Pump Space Heating [55°C]	ErP rating	A++	A++	A++	A++	A++
	SCOP	4.85	4.76	4.0	3.83	3.91
Heating (A7/W35)	Capacity (kW)	15.84	18.77	28.6	40.1	50
	Power Input (kW)	3.36	4.03	7.6	13.1	16.5
	COP***	4.94	4.62	4.54	4.1	4.2
Maximum Flow Temperature	Max (°C)	75	75	75	75	75
Air Temperature Range	Min/Max (°C)	(-20 +40)	(-20 +40)	(-20 +40)	(-20 +40)	(-20 +40)
	Power Level dB(A)**	64	64	65	82	83
Sound Data Outdoor Unit	Pressure Level at 1m dB(A)#	47	47	45	64	65
	Heating Flow (")	1	1	1 ¼	1 ½	1 ½
Pipework Connection Sizes	Heating Return (")	1	1	1 ¼	1 ½	1 ½
	Minimum Water Volume	Litres (l)	230	230	225	365
Dimensions Outdoor Unit	Width (mm)	1100	1100	1610	1895	1895
	Depth (mm)	510	510	710	1110	1110
	Height (mm)	1447	1447	1270	1980	1980
Weight	kg	174	174	285	535	550
	Electrical Supply (v)	400	400	400	400	400
	Phase	Three	Three	Three	Three	Three
Electrical Data	Max Running Current (Amp)	15.8	16.5	21	38	45
	Fuse Rating (Amp)	25	25	25	50	63
	Refrigerant Charge	R290 (kg)	1.27	1.27	2.1	3.15
GWP (Global Warming Potential)		3	3	3	3	3

Terms and conditions apply.

* 2 year warranty extended to 5 years if commissioned by Ideal Heating. ** 64dB(A) is the rated sound power level of the Ecomod 290HT 15kW & 18kW, the sound levels refer to a fully loaded unit at standard nominal conditions according to EN 12102:2022. #Sound pressure: value calculated from the sound power level in condition (9) using the standard UNI EN ISO 3744:2010. *** Efficiency Co-efficient of Performance (COP) rated at EN14825 test conditions Water 35°C, Air 7°C. ECOMOD 290HT models all represent the output at Air 7°C & Water 35°C.

Every effort has been taken to ensure the details are accurate. Ideal Heating does not, however, guarantee the accuracy or completeness of any information nor does it accept liability for any errors or omissions in the information. Ideal Heating reserves the right to make changes and improvements which may necessitate alteration to product specification without prior notice.

ECOMOD 290HT

OUTLINE DRAWINGS & SPECIFICATIONS

ECOMOD 290HT

HEAT PUMPS



15kW & 18kW

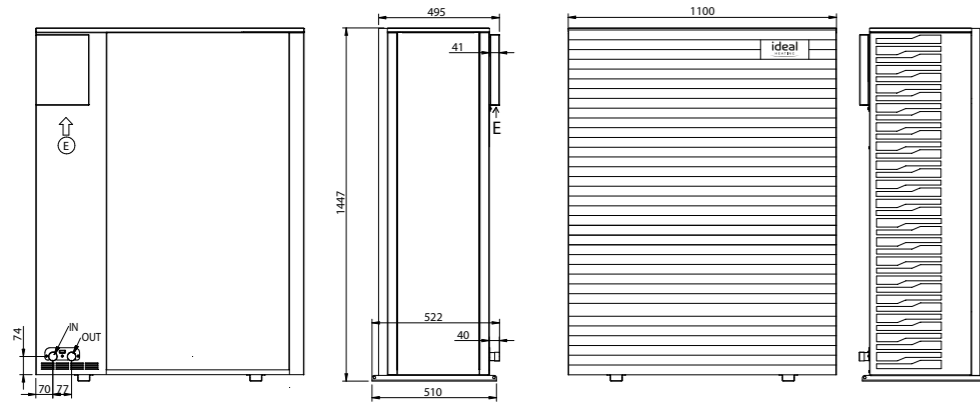

27kW

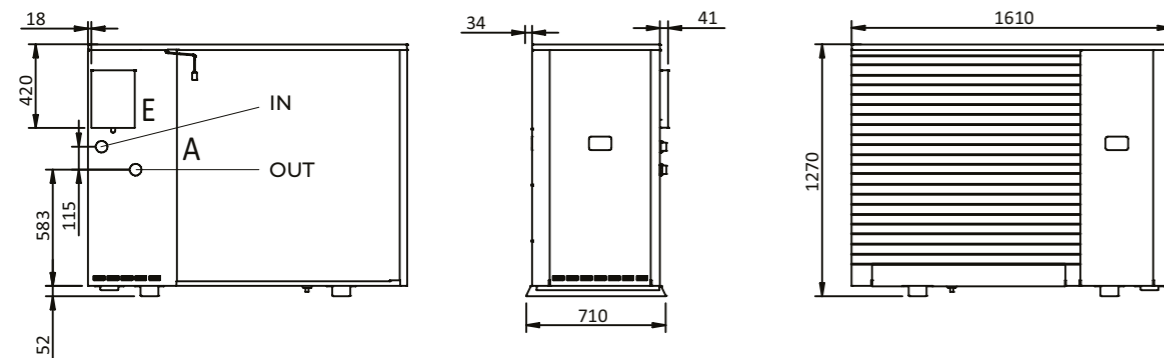

40kW & 50kW

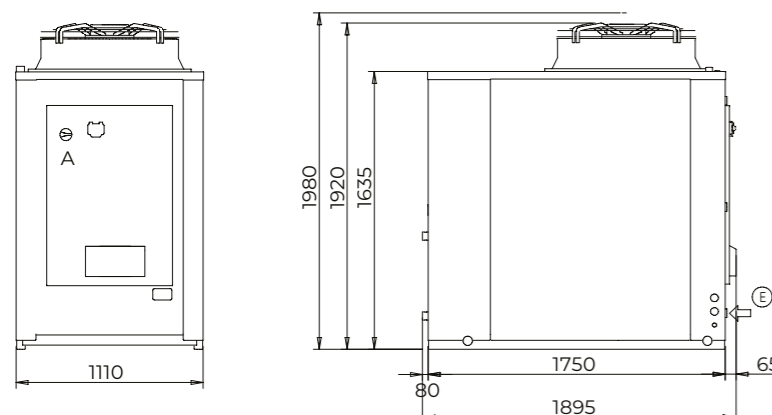

SUGGESTED ENGINEERING SPECIFICATION

The suggested Engineering Specification is wording designed for specifiers to copy and paste into their specifications to ensure inclusion of Ideal Heating commercial heat pumps.

OVERVIEW

The heat pump must have an integrated controller, utilising an inverter controlled compressor, integral circulating pump and suitable for connection to a correctly sized buffer cylinder.

CONTROLS

The heat pump must have connectivity for all common types of BMS integration including 0-10v, volt free and Modbus. Where no BMS is present a controller must be integral to the heat pump, which can adjust and monitor both DHW and heating temperatures, with the ability to control back-up or emergency heaters.

The heat pump must be of inverter type with an inverter circulating pump built in. The controls must have safety lock out parameters including fault diagnosis for the heat pump. Heat pump capabilities must include, with the use of external components, frost protection, weather compensation.

HYDRAULIC

Hydraulic connections are common to each chassis type to ensure ease of installation and maintenance in mixed output cascades. The heat pump must have a maximum operating pressure of 6 bar and be suitable for heating and indirect hot water systems. Pressure Relief valves must be integral.

EFFICIENCY

COP (Coefficient of Performance) measurement of the heat pump must be in line with the site application.

The heat pump must utilise refrigerant R290 with a GWP (Global Warming Potential) of 3. The heat pump must have inverter controlled compressor, modulating integral pump and DC Fan Motor.

DIMENSIONS

The heat pump range must have common chassis sizes within the range to help enable uniform cascade specification.

APPROVALS

The heat pump must have approvals EN 14276-1:2020, EN 14276-2:2020, EN 12735-1:2020, EN 12735-2:2016, EN 378:2017, EN 13134:2002 Components directive 2014/68/UE conformity evaluation modules: Compressors A2: Heat exchangers H +H1: Receivers D1: Valves A: Safety valve.

The manufacturer must be ISO 9001 accredited.

SPECIFICATION

The heat pump will be capable of flow temperatures of up to 75°C with a 5°C Delta T. The heat pump will be connected directly to a correctly sized buffer, to ensure most efficient operation and conform to minimum water quantities for defrost cycles.

SOURCING

The heat pump must be manufactured or finally assembled in Europe.

CASCADE

The heat pump must be configurable up to 7 units (max 350kW) in cascade using one central controller. The controller must be able to sequence the heat pumps to give equal running time per unit.

WARRANTY

The heat pump must be available with a 5-year parts and labour warranty* and available with free commissioning from the manufacturer.

TRAINING

The manufacturer should be able to provide product training either onsite, online, or by attending courses at a one of their training centres.

Please note that the above information is correct at time of publication. Ideal Heating has a policy of continuous development and therefore reserves the right to alter product specifications or any other details without prior notification. * 5 years parts and labour total warranty.

ECOMOD 290HT COEFFICIENT OF PERFORMANCE (COP) GRAPHS

ECOMOD 290HT 15kW

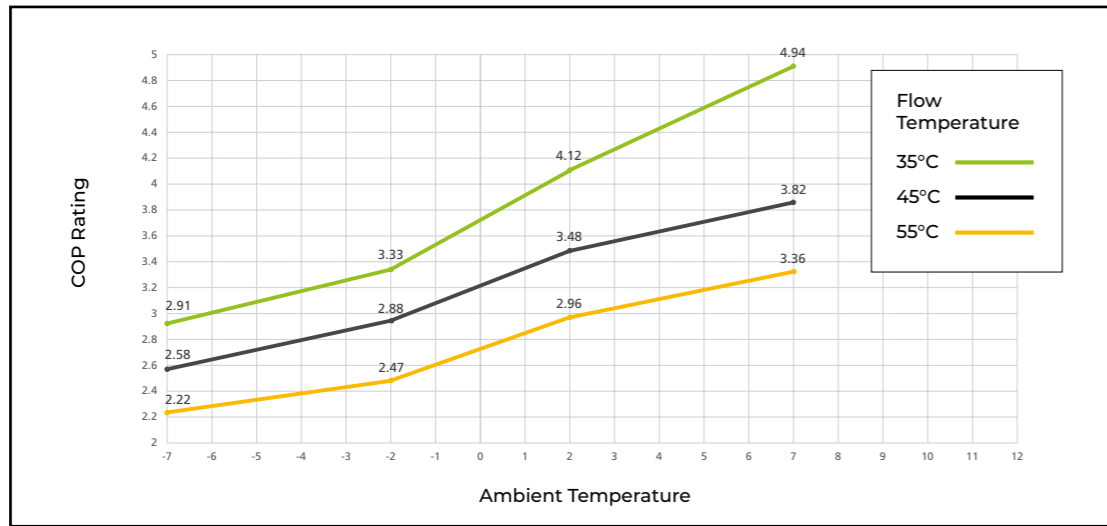

ECOMOD 290HT 40kW

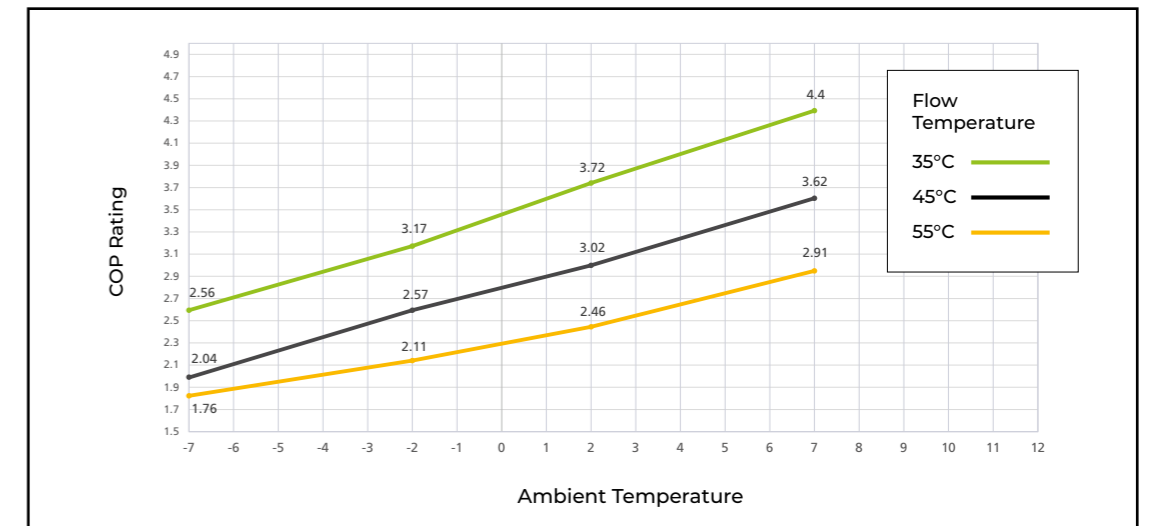

ECOMOD 290HT 18kW

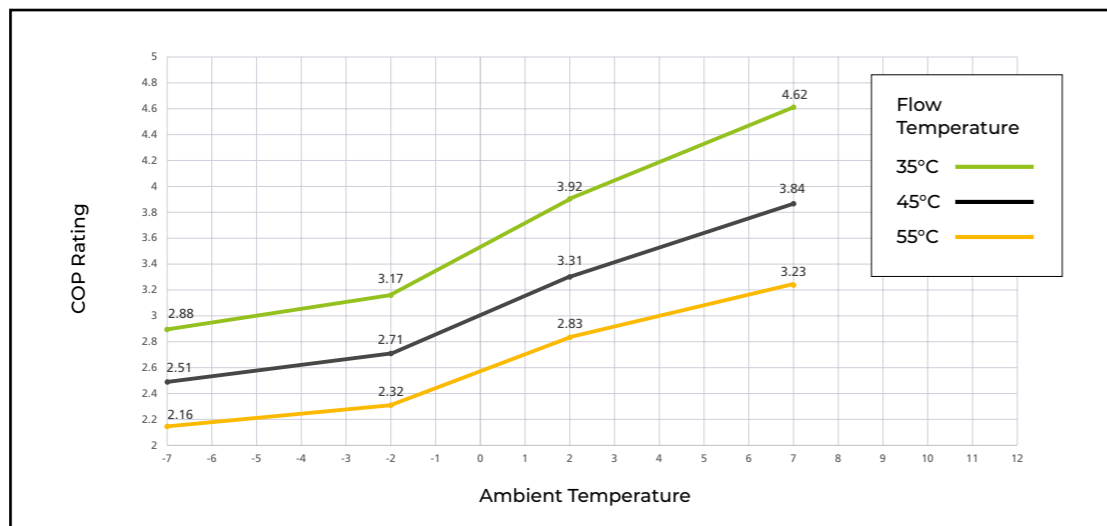

ECOMOD 290HT 50kW

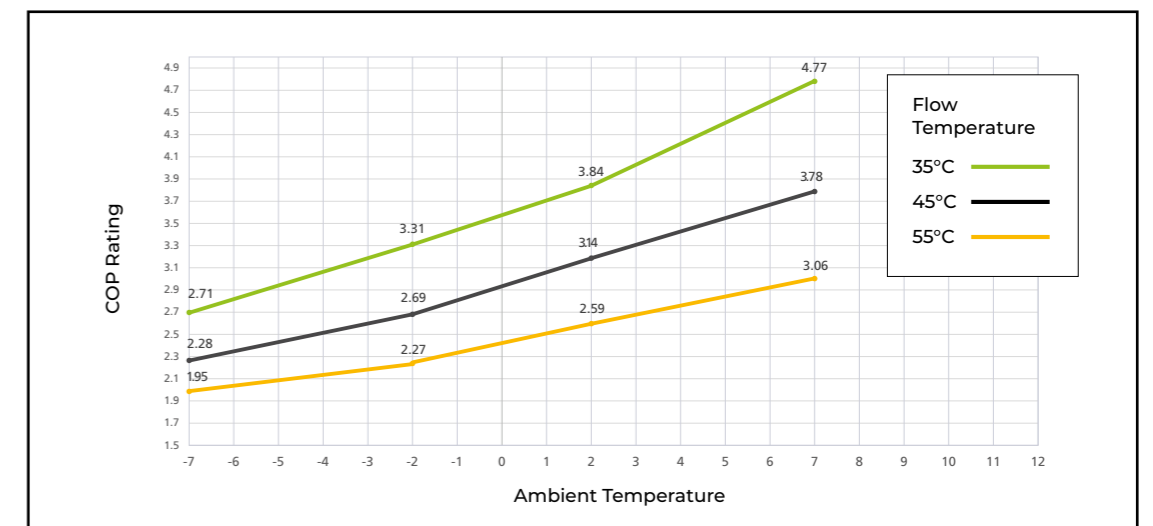

ECOMOD 290HT 27kW

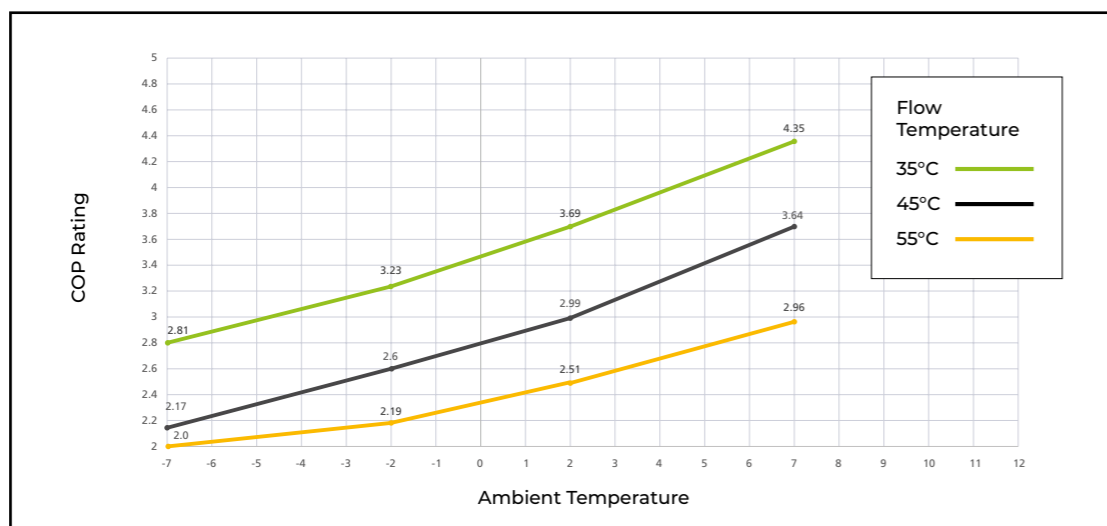

Efficiency coefficient of performance (COP) rated at EN14825 test conditions Water 35°C, Air 7°C.

Efficiency coefficient of performance (COP) rated at EN14825 test conditions Water 35°C, Air 7°C.

ECOMOD CO2Q & CO2 NATURAL REFRIGERANT HEAT PUMPS

65kW, 95kW & 130kW

DESIGNED WITH COMMERCIAL BUILDINGS IN MIND THESE NATURAL REFRIGERANT MONOBLOC AIR SOURCE HEAT PUMPS CAN BE EASILY CASCADED TO ACHIEVE THE HIGHER OUTPUTS NEEDED FOR COMMERCIAL INSTALLATIONS.



The **ECOMOD CO2** and **CO2Q** standard and low noise natural refrigerant monobloc air source heat pumps come in three outputs: **65kW, 95kW** and **130kW**.

Featuring R744 natural refrigerant for ultra-low GWP of 1 they are able to achieve high temperatures up to 70°C.

With 6 models in the two ranges and 3 chasses sizes, these high-performance heat pumps can be used alongside our full portfolio of commercial heating products - cascaded for high output - and meet the growing needs of commercial buildings.

Up to 6 heat pumps can be centrally controlled operating from an intelligent lead controller.



QUIET LOW NOISE

The **low noise CO2Q** models benefit from a quiet dB(A) rating for minimal background noise.

SPACE SAVING

The CO2 & CO2Q models are designed to be placed flush against a wall, ideal for when space is limited..

NATURAL REFRIGERANTS

Use of natural refrigerant helps future proof your investment. Heat pumps using traditional refrigerants could potentially become obsolete due to any changes to F-Gas regulations.

Monobloc air source heat pumps with ultra-low global warming potential due to the use of R744 refrigerant.
High temperatures up to 70°C.

ECOMOD CO2Q & CO2 HEAT PUMPS

FEATURES & SPECIFICATION

- Monobloc air source heat pump
- Quiet noise level as low as 71dB(A)**
- Single unit with the refrigeration cycle contained within the outdoor unit
- Inverter controlled compressor to accurately match the heat demand
- Ultra-low GWP of 1 due to the use of R744 (CO2) natural refrigerant
- Highly efficient coefficient of performance (COP) rating
- Can be installed in cascade or in back-back arrangement
- Suited to larger installations - cascade systems to achieve higher output
- 2 year parts only warranty*
- Combine with Ideal industry leading boilers for a hybrid heating system

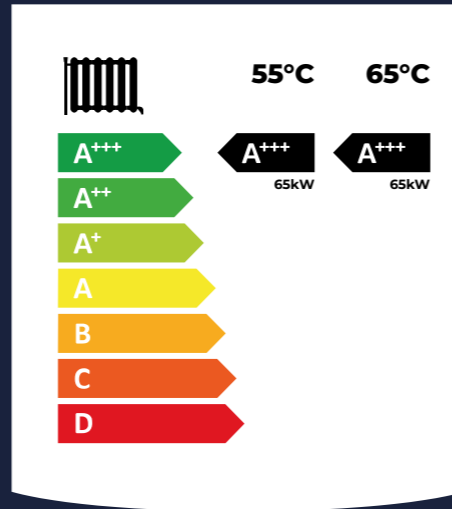

ACCESSORIES & OPTIONS

	INCLUDED	OPTIONAL
Master controller		✓
DHW controller		✓
Flexible hoses		✓
Burst disc pressure relief kit		✓
Exogel antifreeze kit		✓
Anti-corrosion Blygold coating available for installations near the sea		✓

Note: Designed to sit back to wall or in back to back arrangement.

INSTALLATION CLEARANCES

	FRONT	REAR	LEFT	RIGHT
	1000	0	1000	1000

All measurements in mm unless otherwise stated.



BIM objects available to download at: idealcommercialheating.com/bim

TECHNICAL SPECIFICATIONS



ECOMOD CO2

		65kW	95kW	130kW
Heat Pump Space Heating [55°C]	ErP rating	A+++	N/A	N/A
	COP	3	3	3
Heat Pump Space Heating [65°C]	ErP rating	A+++	N/A	N/A
	COP***	3.4	3.4	3.4
Heating (A7/W65)	Capacity (kW)	65	95	130
	Power Input (kW)	17	25	34
Maximum Flow Temp	°C	70	70	70
	Air Temperature Range	Min/Max (°C)	-15 / no max	-15 / no max
Sound Data Outdoor Unit	Power Level dB(A)**	74	75	75
	Pressure Level at 10m dB(A)#	43	44	44
Pipework Connection Sizes	Heating Flow (mm)	28	35	42
	Heating Return (mm)	28	35	42
Dimensions Outdoor Unit	Width (mm)	2190	3051	3101
	Depth (mm)	1160	1160	1457
	Height (mm)	1853	1853	1853
Weight	kg	935	1260	1300
	Electrical Supply (v)	400	400	400
Electrical Data	Phase	Three	Three	Three
	Max Running Current (Amp)	45.07	67.55	82.19
	Fuse Rating (Amp)	63	80	100
Refrigerant Charge	CO2 (kg)	4.8	6.5	10
GWP (Global Warming Potential)		1	1	1

ECOMOD CO2Q

		65kW	95kW	130kW
Heat Pump Space Heating [55°C]	ErP rating	A+++	N/A	N/A
	COP	3	3	3
Heat Pump Space Heating [65°C]	ErP rating	A+++	N/A	N/A
	COP***	3.4	3.4	3.4
Heating (A7/W65)	Capacity (kW)	65	95	130
	Power Input (kW)	17	25	34
Maximum Flow Temp	°C	70	70	70
	Air Temperature Range	Min/Max (°C)	-15 / no max	-15 / no max
Sound Data Outdoor Unit	Power Level dB(A)**	71	72	72
	Pressure Level at 10m dB(A)#	40	40	40
Pipework Connection Sizes	Heating Flow (mm)	28	35	42
	Heating Return (mm)	28	35	42
Dimensions Outdoor Unit	Width (mm)	2190	3051	3101
	Depth (mm)	1160	1160	1457
	Height (mm)	2401	2401	2401
Weight	kg	1000	1365	1590
	Electrical Supply (v)	400	400	400
Electrical Data	Phase	Three	Three	Three
	Max Running Current (Amp)	45.07	67.55	82.19
	Fuse Rating (Amp)	63	80	100
Refrigerant Charge	CO2 (kg)	4.8	6.5	10
GWP (Global Warming Potential)		1	1	1

Terms and conditions apply.

* 2 year parts only warranty. ** Sound power established in general accordance with BS EN ISO 3740: 2019 with a survey grade accuracy (sR0) = 4 dB. # Sound pressure level at 10m determined in accordance with Annex D of BS EN ISO 13487(TC): 2019. *** Efficiency Co-efficient of Performance (COP) rated at EN14825 test conditions Air 7°C / Water 65°C.

ECOMOD CO2 & CO2Q models all represent the output at Air 7°C & Water 65°C.

Every effort has been taken to ensure the details are accurate. Ideal Heating does not, however, guarantee the accuracy or completeness of any information nor does it accept liability for any errors or omissions in the information. Ideal Heating reserves the right to make changes and improvements which may necessitate alteration to product specification without prior notice.

ECOMOD CO2 & CO2Q

OUTLINE DRAWINGS & SPECIFICATIONS

ECOMOD CO2Q

& CO2 HEAT PUMPS

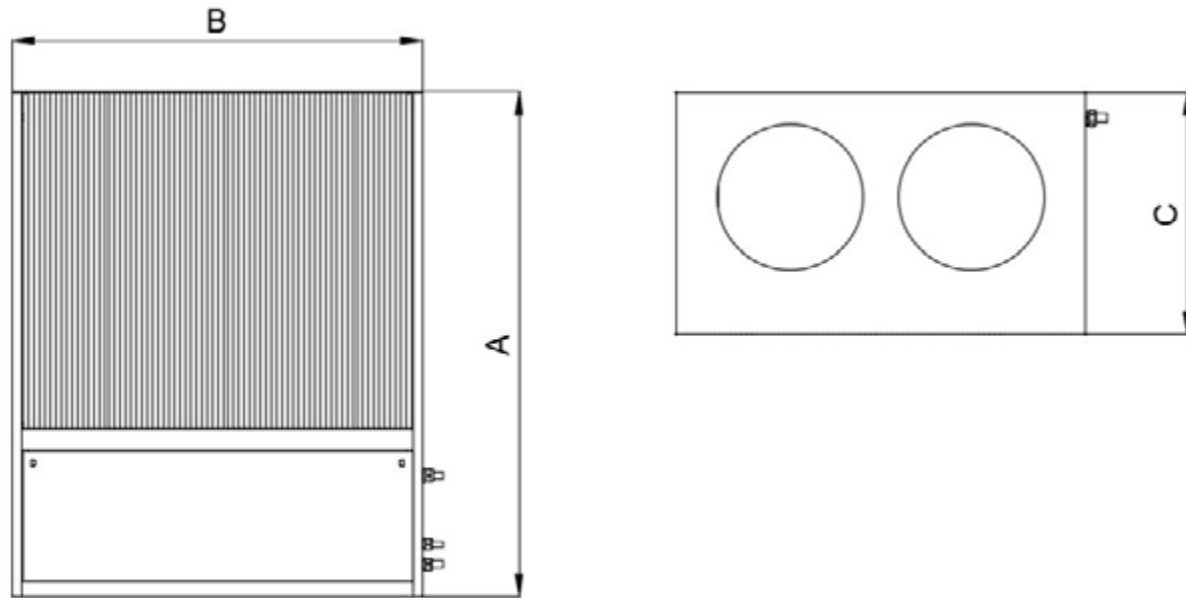

DIMENSIONS		ECOMOD 65kW	ECOMOD 95kW	ECOMOD 130kW
A	Height (mm) CO2Q	2401	2401	2401
A	Height (mm) CO2	1853	1853	1853
B	Width (mm)	2190	3051	3101
C	Depth (mm)	1160	1160	1457

SUGGESTED ENGINEERING SPECIFICATION

The suggested Engineering Specification is wording designed for specifiers to copy and paste into their specifications to ensure inclusion of Ideal Heating commercial heat pumps.

OVERVIEW

The heat pump must have an integrated controller, utilising an inverter controlled compressor, integral circulating pump and suitable for connection to a correctly sized buffer cylinder.

CONTROLS

The heat pump must have connectivity for all common types of BMS integration including 0-10v, volt free and Modbus. Where no BMS is present a controller must be integral to the heat pump, which can adjust and monitor both DHW and heating temperatures, with the ability to control back up or emergency heaters.

The heat pump must be of inverter type with an inverter circulating pump built in.

The controls must have safety lock out parameters including fault diagnosis for the heat pump.

Heat Pump capabilities must include, with the use of external components, frost protection, weather compensation.

HYDRAULIC

Hydraulic connections are common to each chassis type to ensure ease of installation and maintenance in mixed output cascades. The heat pump must have a maximum operating pressure of 6 bar and be suitable for heating and indirect hot water systems. Pressure Relief valves must be integral.

DIMENSIONS

The heat pump range must have a universal height across their respective range to ensure mixed output cascades maintain the same universal configuration.

EFFICIENCY

COP of the heat pump must be in line with site application.

The heat pump must utilise refrigerant R744 (CO2) with a GWP (Global Warming Potential) of 1.

Heat Pump must have inverter controlled compressor, modulating integral pump and DC fan motors.

SPECIFICATION

The heat pump will be capable of flow temperatures of up to 70°C with a return of 35°C

The heat pump will be connected directly to a correctly sized buffer, to ensure most efficient operation and conform to minimum water quantities for defrost cycles.

SOURCING

The heat pump must be manufactured or finally assembled in the UK.

CASCADE

The heat pump must be configurable up to 6 units (max 780kW) in cascade using one central controller.

The controller must be able to sequence the heat pumps to give equal running time per unit.

WARRANTY

The heat pump must be available with a two year parts only warranty with free commissioning from the manufacturer.

TRAINING

The manufacturer should be able to provide product training either onsite, online, or by attending courses at a one of their training centres.

Please note that the above information is correct at time of publication. Ideal Heating has a policy of continuous development and therefore reserves the right to alter product specifications or any other details without prior notification.

ECOMOD CO2Q COEFFICIENT OF PERFORMANCE (COP) GRAPHS

ECOMOD
CO2Q
65kW

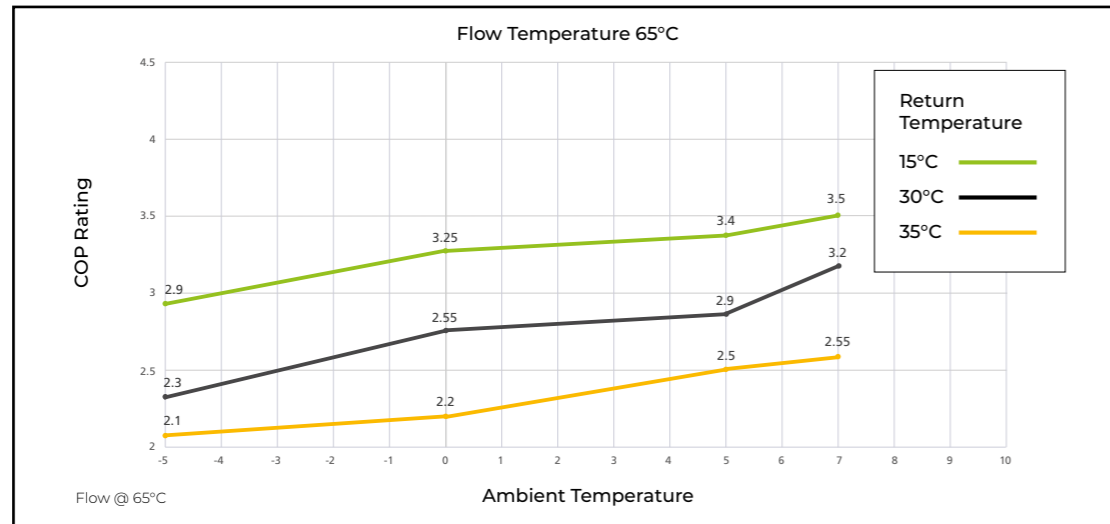

ECOMOD
CO2Q
95kW

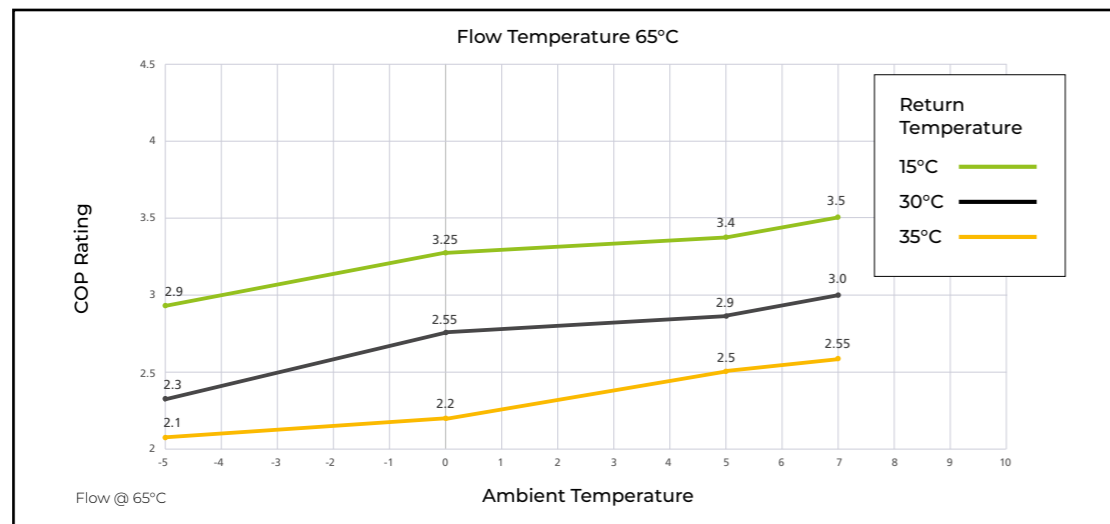

ECOMOD
CO2Q
130kW

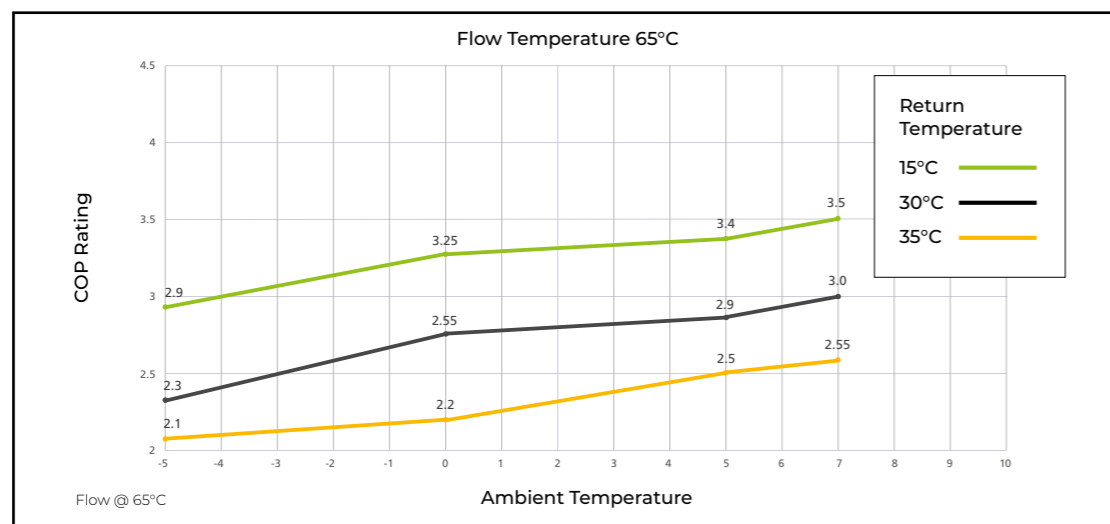

ECOMOD CO2 COEFFICIENT OF PERFORMANCE (COP) GRAPHS

ECOMOD
CO2
65kW

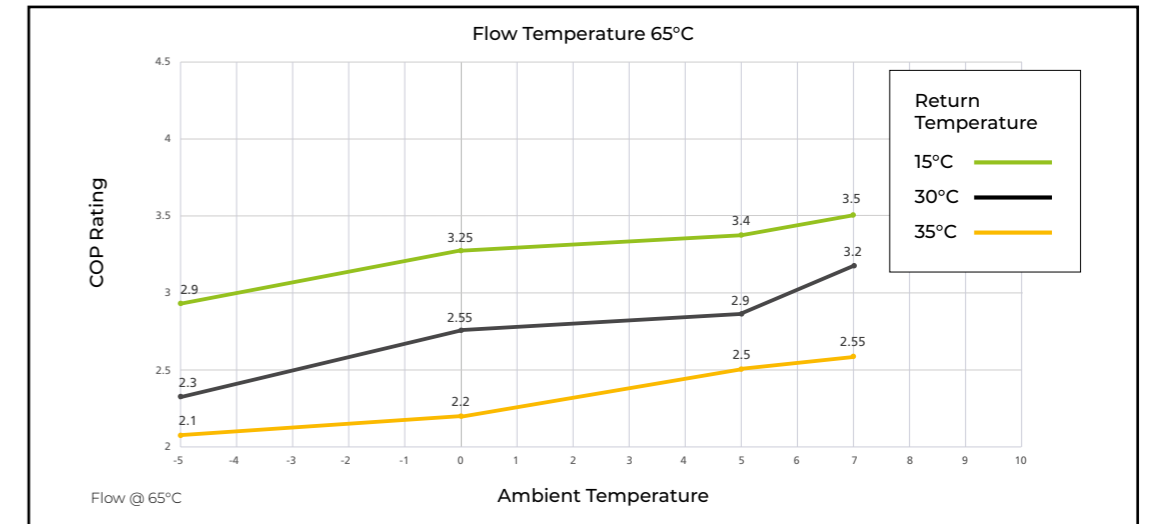

ECOMOD
CO2
95kW

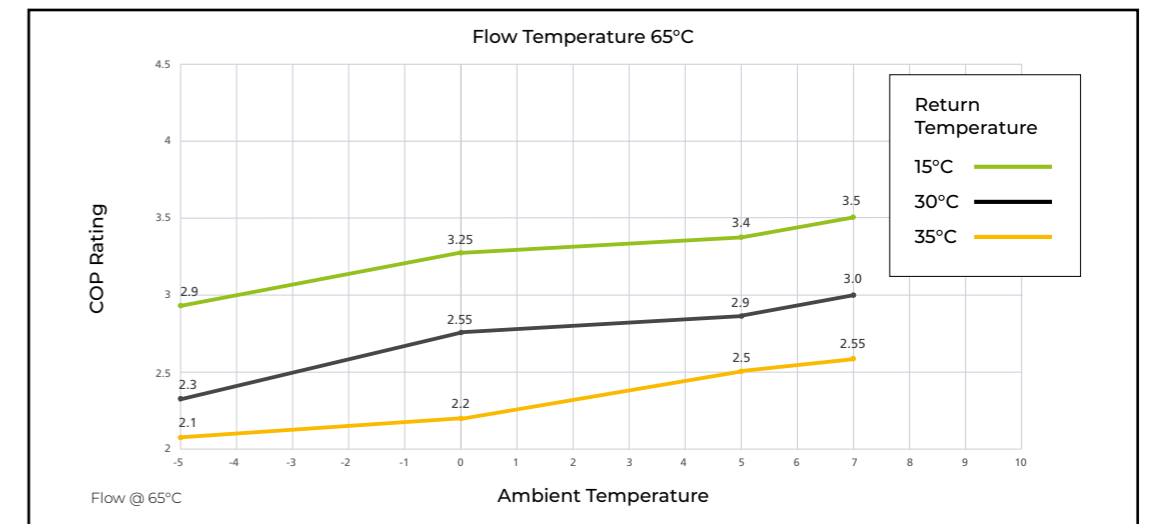

ECOMOD
CO2
130kW

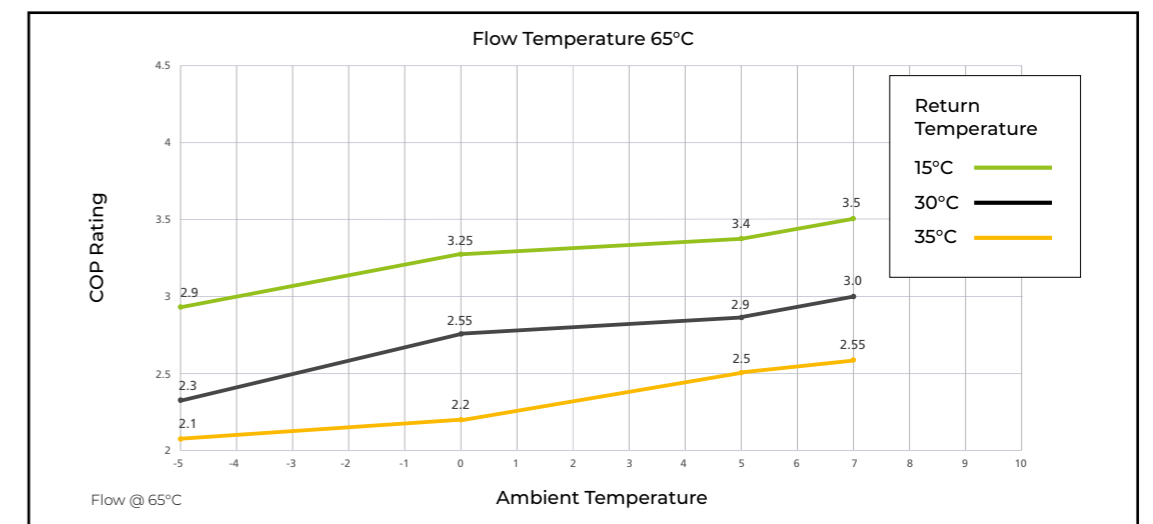

ECOMOD RANGE COMMERCIAL HEAT PUMPS

14kW, 18kW, 26kW, 32kW, 50kW & 70kW

THE ORIGINAL ECOMOD MONOBLOC AIR SOURCE HEAT PUMPS HAVE BEEN DESIGNED WITH COMMERCIAL BUILDINGS IN MIND AND WILL DELIVER THE NEXT GENERATION OF HEATING SOLUTIONS.

5
YEAR WARRANTY*



Suitable for commercial properties



Cascade for higher outputs

R32
REFRIGERANT



R32
REFRIGERANT

Low environmental impact

68
dB(A)

Quiet noise level as low as 68 dB(A)**

4.85
COP

Highly efficient: COP up to 4.85***

R32
REFRIGERANT

Utilising R32 refrigerant, the original **ECOMOD** monobloc air source heat pumps have low environmental impact and highly efficient COP performance rating up to 4.85 and a low global warming potential to provide you with efficient low carbon heating.

The monobloc design means all components are housed in the main unit and are built to meet the changing commercial heating market needs.

With 7 models in the range, **14kW, 18kW, 26kW, 32kW, 50kW** and **70kW**, these high-performance heat pumps can be used alongside our full portfolio of commercial heating products. They are able to cascade for high output up to 490kW and meet the growing needs of commercial buildings.

Our new heat pumps are an integral part of any low carbon heating solution.



50 & 70kW

26 & 32kW

14 & 18kW

IN STOCK

Monobloc air source heat pumps with up to 4.85 COP and R32 refrigerant. **Cascade up to 490kW for commercial installations.**

ECOMOD HEAT PUMPS

FEATURES & SPECIFICATION

- Monobloc air source heat pump
- Single unit with the refrigeration cycle contained within the outdoor unit
- Inverter controlled compressor to accurately match the heat demand
- Low global warming potential due to the use of R32 refrigerant
- Highly efficient coefficient of performance (COP) rating
- Suited to larger installations - cascade systems to achieve higher output
- 2-year warranty (extended to 5 years if commissioned by Ideal Heating)*
- Blue Fin anti-corrosion coating as standard
- 14kW single phase unit available - suitable for sites without access to 3 phase electricity, e.g. care homes, community halls, etc
- Combine with Ideal industry leading boilers for a hybrid heating system

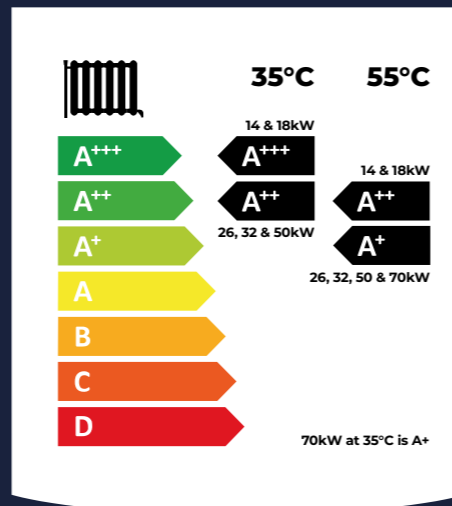

ACCESSORIES & OPTIONS

	INCLUDED	REQUIRED
Control unit	✓	
Flexible hoses		✓
Anti-vibration rubber feet		✓
Exogel antifreeze kit		✓



BIM objects available to download at:
idealcommercialheating.com/bim

INSTALLATION CLEARANCES

14 & 18kW

	FRONT	REAR	LEFT	RIGHT	TOP	BOTTOM
	1500	400	400	500	500	50

26 & 32kW

	FRONT	REAR	LEFT	RIGHT	TOP	BOTTOM
	1500	400	400	700	500	50

50 & 70kW

	FRONT	REAR	LEFT	RIGHT	TOP	BOTTOM
	1500	1500	1200	1000	1500	50

Side clearance of 1000mm 14 & 18kW, 700mm 26 & 32kW and 2200mm 50 & 70kW when used in cascade. The outdoor unit must be raised by at least 50mm from the ground. All measurements in mm unless otherwise stated.

TECHNICAL SPECIFICATIONS



ECOMOD

		14kW (1 Phase)	14kW (3 Phase)	18kW	
Heat Pump Space Heating [35°C]	ErP rating	A+++	A+++	A+++	
	SCOP	4.48	4.48	4.46	
Heat Pump Space Heating [55°C]	ErP rating	A++	A++	A++	
	SCOP	3.31	3.31	3.36	
Heating (A7/W35)	Capacity (kW)	14.1	14.1	17.96	
	Power Input (kW)	2.91	2.91	4.07	
	COP***	4.85	4.85	4.4	
Max Flow Temp °C	Max (°C)	55	55	55	
Air Temperature Range	Min/Max (°C)	(-20 +40)	(-20 +40)	(-20 +40)	
Sound Data Outdoor Unit	Power Level dB(A)**	68	68	68	
	Pressure Level at 1m dB(A)#	53	53	53	
Pipework Connection Sizes	Heating Flow (")	1	1	1	
	Heating Return (")	1	1	1	
Dimensions Outdoor Unit	Width (mm)	1044	1044	1044	
	Depth (mm)	455	455	455	
	Height (mm)	1409	1409	1409	
Weight	kg	121	136	141	
	Electrical Supply (v)	240	415	415	
Electrical Data	Phase	Single	Three	Three	
	Max Running Current (Amp)	29.2	9.7	12.2	
	Fuse Rating (Amp)	32	25	25	
Refrigerant Charge	R32 (kg)	3.2	3.2	3.5	
		26kW	32kW	50kW	70kW
Heat Pump Space Heating [35°C]	ErP rating	A++	A++	A++	A++
	SCOP	4.55	4.81	4.16	3.94
Heat Pump Space Heating [55°C]	ErP rating	A+	A+	A+	A+
	SCOP	3.14	3.14	3.08	3.04
Heating (A7/W35)	Capacity (kW)	26	32.1	50.2	66.8
	Power Input (kW)	6.44	7.84	12.2	16.3
	COP***	4.04	4.09	4.11	4.1
Max Flow Temp °C	Max (°C)	55	55	55	55
Air Temperature Range	Min/Max (°C)	(-20 +40)	(-20 +40)	(-20 +40)	(-20 +40)
Sound Data Outdoor Unit	Power Level dB(A)**	74	76	82	83
	Pressure Level at 1m dB(A)#	58	60	65	66
Pipework Connection Sizes	Heating Flow (")	1	1 ¼	1 ½	1 ½
	Heating Return (")	1	1 ¼	1 ½	1 ½
Dimensions Outdoor Unit	Width (mm)	1600	1600	1920	1920
	Depth (mm)	680	680	1110	1110
	Height (mm)	1315	1315	1920	1920
Weight	kg	240	255	535	595
	Electrical Supply (v)	415	415	415	415
Electrical Data	Phase	Three	Three	Three	Three
	Max Running Current (Amp)	23.3	27.1	54	70
	Fuse Rating (Amp)	25	32	63	100
Refrigerant Charge	R32 (kg)	4.3	5.1	8.5	12

Terms and conditions apply. * 2 year warranty extended to 5 years if commissioned by Ideal Heating **The dB(A) rated sound power levels refer to a fully loaded unit at standard nominal conditions in accordance with EU Regulation 813/2013. *** Efficiency Co-efficient of Performance (COP) rated at EN14825 test conditions Water 35°C, Air 7°C. models. †Gold Fin anti-corrosion coating standard on 14kW & 18kW anti-corrosion coating on other models available, as optional extra. ‡ Refers to 14kW, 18kW, 26kW & 32 kW models. Every effort has been taken to ensure the details are accurate. Ideal Heating does not, however, guarantee the accuracy or completeness of any information nor does it accept liability for any errors or omissions in the information. Ideal Heating reserves the right to make changes and improvements which may necessitate alteration to product specification without prior notice.

ECOMOD

OUTLINE DRAWINGS & SPECIFICATIONS

14kW & 18kW

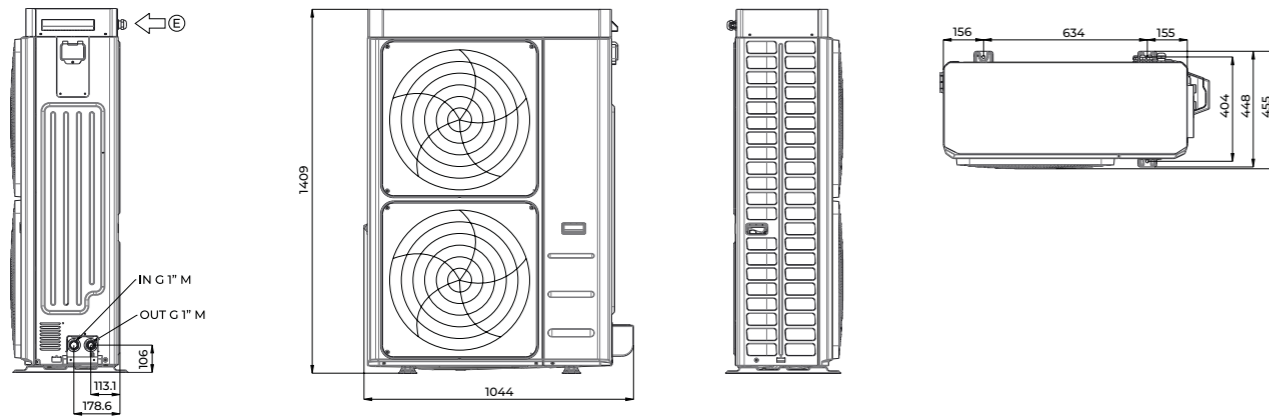

26kW & 32kW

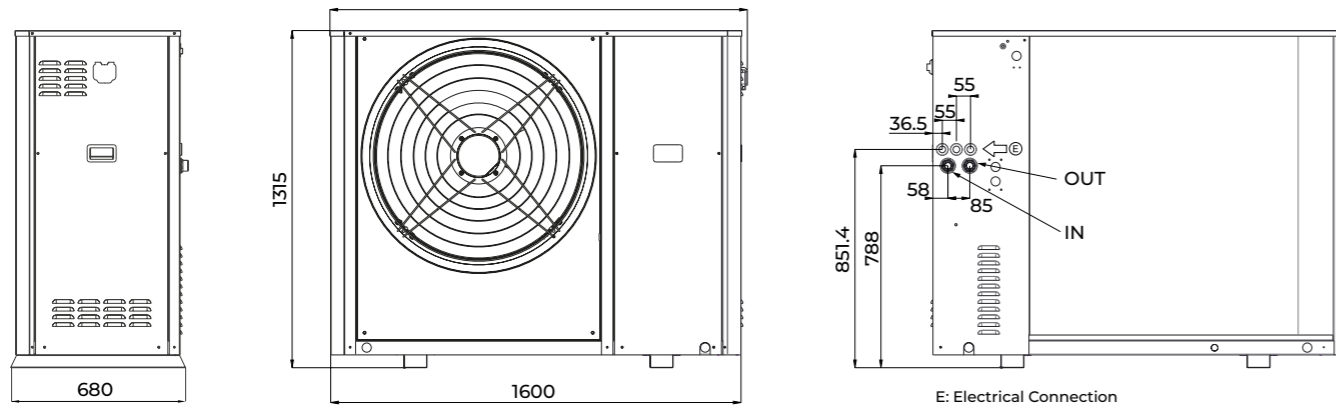

50kW & 70kW

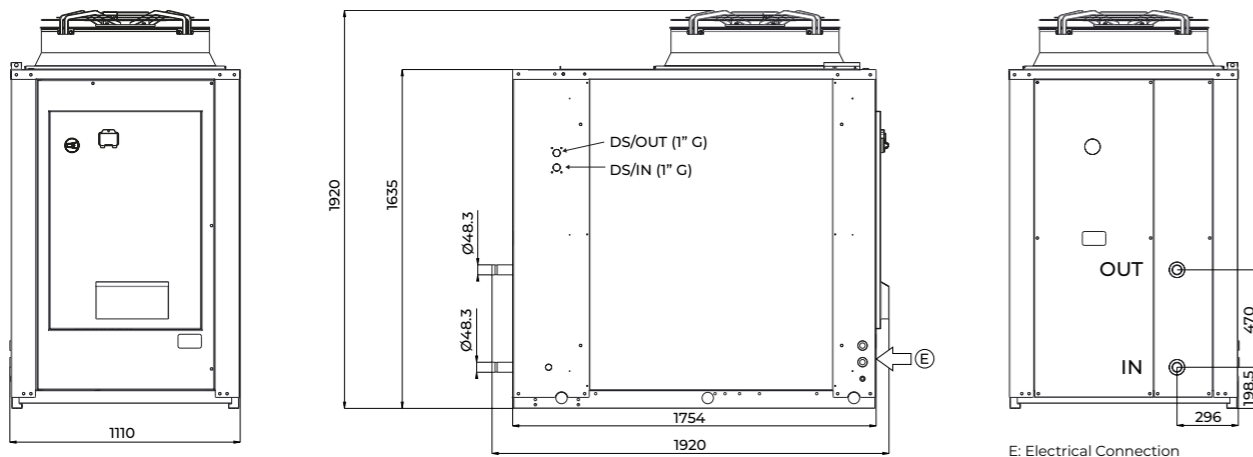

ECOMOD HEAT PUMPS



SUGGESTED ENGINEERING SPECIFICATION

The suggested Engineering Specification is wording designed for specifiers to copy and paste into their specifications to ensure inclusion of Ideal Heating commercial heat pumps.

OVERVIEW

The heat pump must have an integrated controller, utilising an inverter controlled compressor, integral circulating pump and suitable for connection to a correctly sized buffer cylinder.

CONTROLS

The heat pump must have connectivity for all common types of BMS integration including 0-10v, volt free and Modbus. Where no BMS is present a controller must be integral to the heat pump, which can adjust and monitor both DHW and heating temperatures, with the ability to control back-up or emergency heaters.

The heat pump must be of inverter type with an inverter circulating pump built in. The controls must have safety lock out parameters including fault diagnosis for the heat pump. Heat pump capabilities must include, with the use of external components, frost protection, weather compensation.

HYDRAULIC

Hydraulic connections are common to each chassis type to ensure ease of installation and maintenance in mixed output cascades. The heat pump must have a maximum operating pressure of 6 bar and be suitable for heating and indirect hot water systems. Pressure Relief valves must be integral.

DIMENSIONS

The heat pump range must have common chassis sizes within the range to help enable uniform cascade specification.

EFFICIENCY

COP (Coefficient of Performance) measurement of the heat pump must be in line with the site application.

The heat pump must utilise refrigerant R32 with a GWP (Global Warming Potential) of 675. The heat pump must have inverter controlled compressor, modulating integral pump and DC Fan Motor.

APPROVALS

The heat pump must have approvals EN 14276-1:2020, EN 14276-2:2020, EN 12735-1:2020, EN 12735-2:2016, EN 378:2017, EN 13134:2002 Components directive 2014/68/UE conformity evaluation modules: Compressors A2: Heat exchangers H +H1: Receivers D1: Valves A: Safety valve.

The manufacturer must be ISO 9001 accredited.

SPECIFICATION

The heat pump will be capable of flow temperatures of up to 55°C with a 5°C Delta T. The heat pump will be connected directly to a correctly sized buffer, to ensure most efficient operation and conform to minimum water quantities for defrost cycles.

SOURCING

The heat pump must be manufactured or finally assembled in Europe.

CASCADE

The heat pump must be configurable up to 7 units (max 490kW) in cascade using one central controller. The controller must be able to sequence the heat pumps to give equal running time per unit.

WARRANTY

The heat pump must be available with a 5-year parts and labour warranty* and available with free commissioning from the manufacturer.

TRAINING

The manufacturer should be able to provide product training either onsite, online, or by attending courses at a one of their training centres.

Please note that the above information is correct at time of publication. Ideal Heating has a policy of continuous development and therefore reserves the right to alter product specifications or any other details without prior notification. * 5 years parts and labour total warranty.

ECOMOD COEFFICIENT OF PERFORMANCE (COP) GRAPHS

ECOMOD 14kW

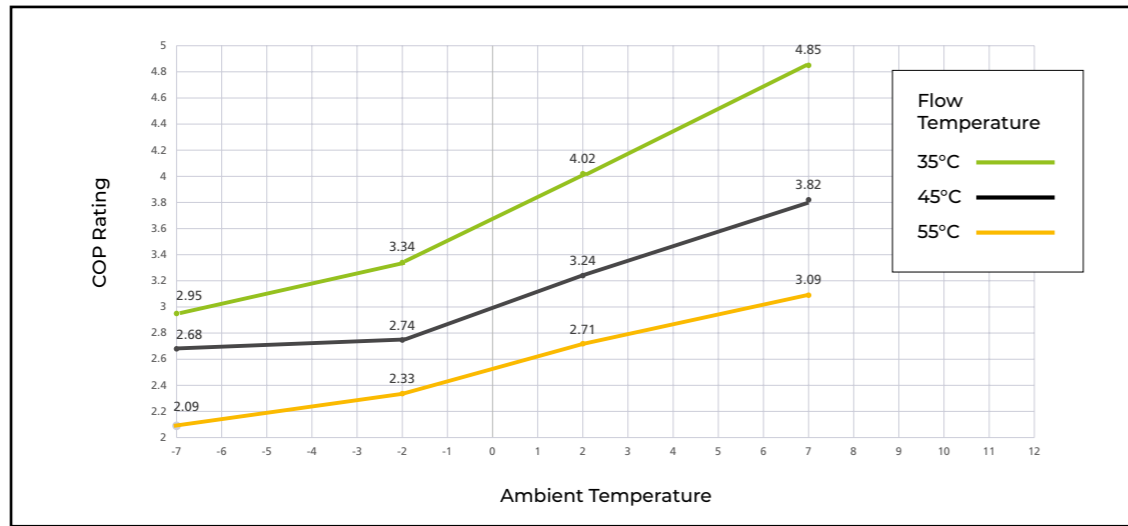

ECOMOD 32kW

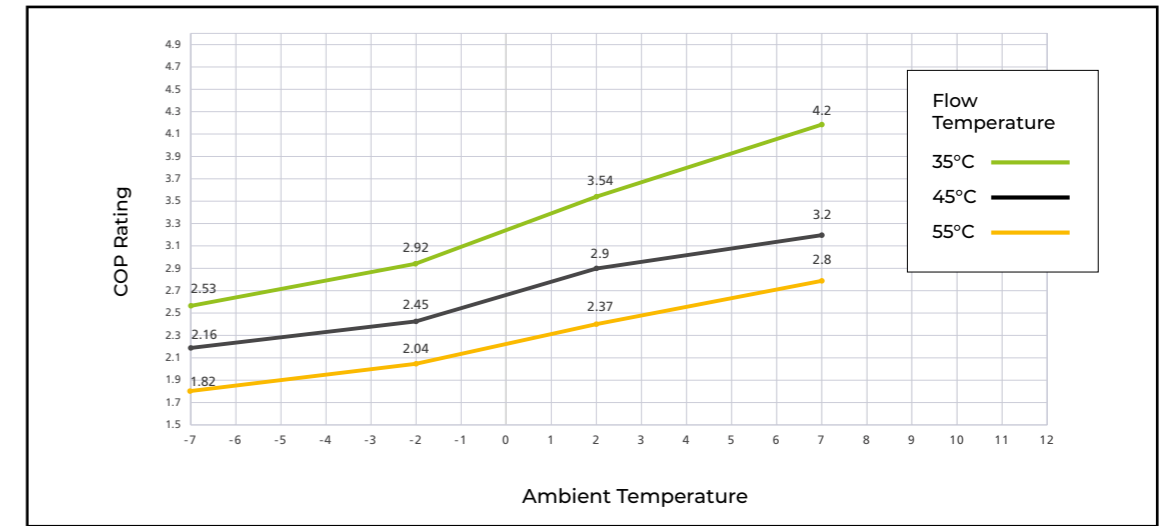

ECOMOD 18kW

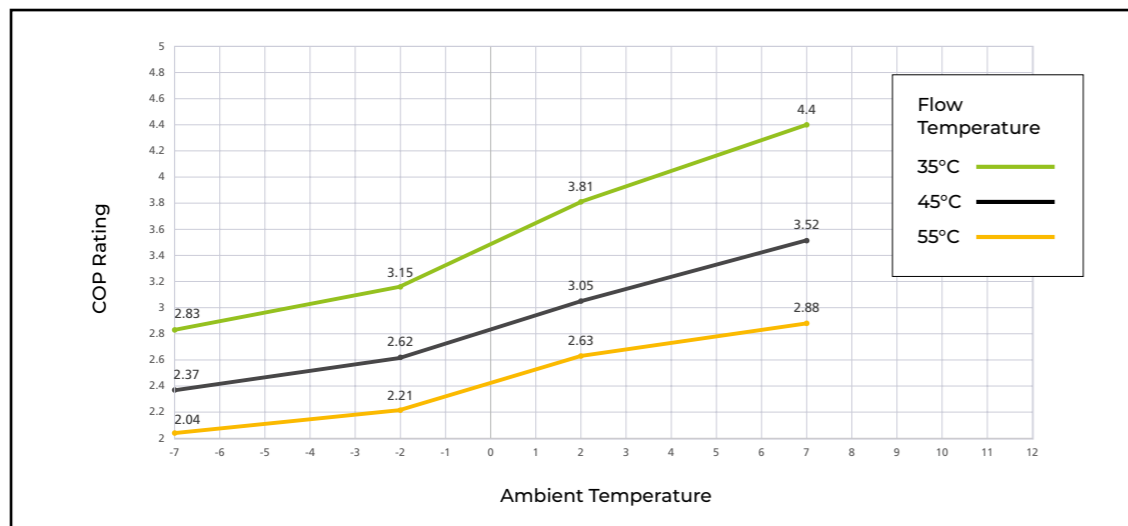

ECOMOD 50kW

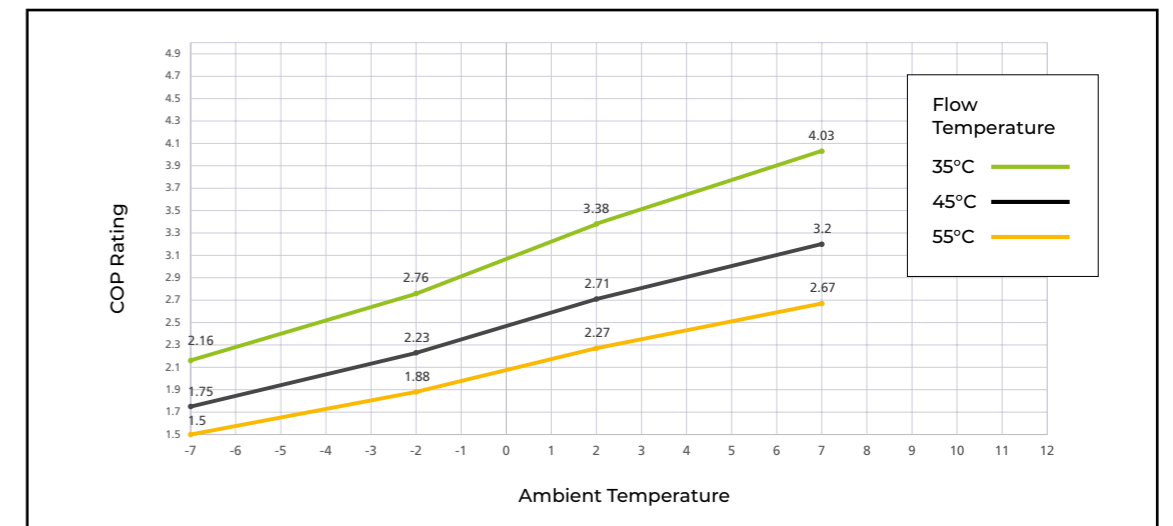

ECOMOD 26kW

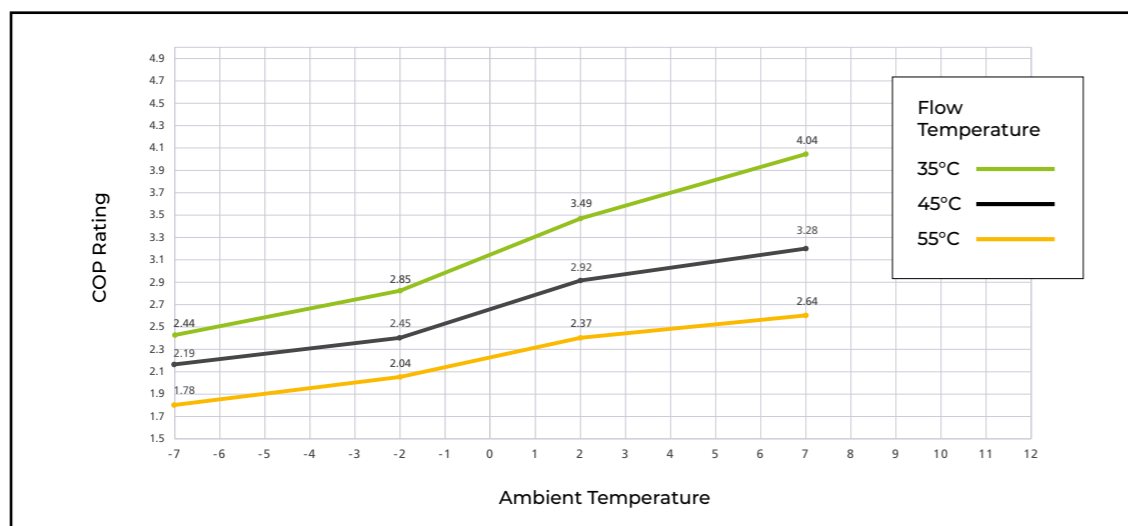

ECOMOD 70kW

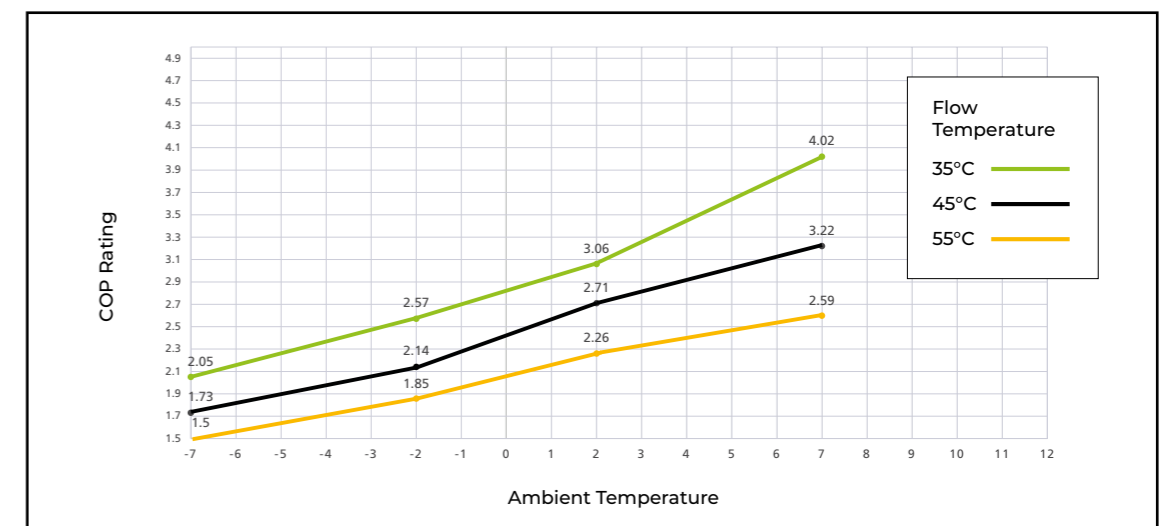

Efficiency coefficient of performance (COP) rated at EN14825 test conditions Water 35°C, Air 7°C.

Efficiency coefficient of performance (COP) rated at EN14825 test conditions Water 35°C, Air 7°C.

BUFFER TANKS

FOR USE WITH ECOMOD AND ECOMOD 290HT COMMERCIAL HEAT PUMPS (UTILISING R32 AND R290 REFRIGERANT)

A buffer tank is typically just an insulated vessel of water; it doesn't usually contain any coils or heat exchangers; most will have top and bottom connections, and some will have a baffle plate internally. The primary role of a buffer tank is to keep a minimum volume of water 'in circuit' at times when the heating load is very low. This prevents the heat pump from short cycling and provides a bypass route to maintain the minimum flow rate through the heat pump if most of the heating zones have shut down.

Both the minimum flow rate and the minimum volume of water in circuit are necessary to keep the heat pump happy. Short cycling can cause several issues: loss of energy efficiency, reduced compressor life, power network disruption and, very rarely, sudden compressor failure due to lubrication starvation. Secondary to that, the ASHP needs to defrost. To do this it has to have a volume of warm water to utilise for this function.

TECHNICAL FEATURES AND PERFORMANCE CAPABILITIES

FEATURES	PRIMARY TANK MODELS					
	100	200	500 0F*	500 3F*	900 2F*	1500 2F*
Useful capacity (L)	95	195	517	517	904	1425
Passage width (mm)	N/A	N/A	680	680	795	1015
Min. room height for installation (mm)	N/A	N/A	2100	2100	2415	2415
Tilting dimension (mm)(1)	N/A	N/A	1980	1980	2240	2270
Empty tank weight (kg)	23	34	72	72	140	180
Thermal losses(2) Ua (W/K). Flexible M1	0.384	0.232	1.38	1.657	2.231	2.778

(1) Risers not mounted.

(2) Storage at 65°C - Ambient temperature at 20°C. Values supported per RT2012.

DIMENSIONS

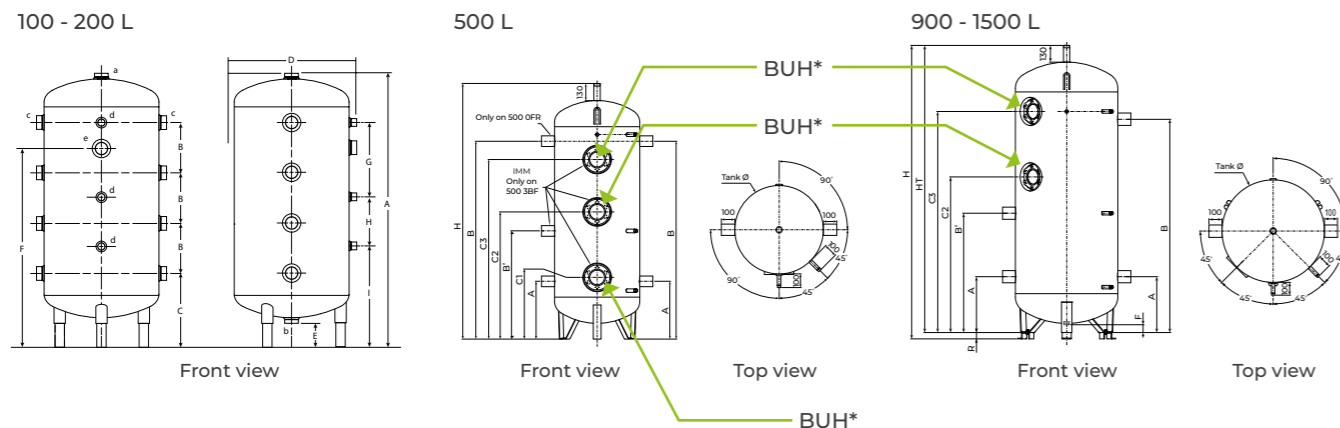

REFERENCES	DESCRIPTION	UNITS	PRIMARY TANK MODELS			
			500 0F*	500 3F*	900 2F*	1500 2F*
Tank Ø	Tank diameter without insulation	mm	650	650	790	1000
HT	Tank overall height (height without riser)	mm	1950	1950	2215	2215
H	Height with risers	mm	1950	1950	2265	2265
A	Lower connection	mm	440	440	430	500
B	Upper connection	mm	1510	1510	1645	1460
B'	Intermediate connection	mm	-	825	920	915
C1	Lower clamp height	mm	-	470	-	-
C2	Intermediate clamp height	mm	-	970	1200	1077
C3	Upper clamp height	mm	-	1370	1705	1630
F	Drainage height	mm	110	110	60	60
R	Riser height	mm	-	-	50	50
1	Temperature probe branch pipe				1/2" F Through type	
2	Thermometer branch pipe				1/2" F Through type	
3	Branch pipe connection			2 1/2" F		3" F
4	Purge			1 1/2" M		2" M
5	Drain				1 1/4" F	
BUH	Back-up heater mounting			3-of	2-of	2-of

*0F - 0 flange connection / 2F - 2 flange connection / 3F - 3 flange connection

REFERENCES	100L	200L
A	950	1435
B	170	330
C	255	265
D	460	510
E	80	80
F	690	1070
G	255	485
H	170	325
I	345	440
a	1 1/4" F	1 1/4" F
b	1 1/4" F	1 1/4" F
c	1 1/4" F	1 1/4" F
d	1 1/2" F	1 1/2" F
e	1 1/2" F	1 1/2" F
Weight (kg)	23	34

For advice or more information on specifying buffer tanks contact your Ideal Heating Commercial business development manager [idealcommercialheating.com/contact-us](https://www.idealcommercialheating.com/contact-us)



FUNCTIONAL DIAGRAM

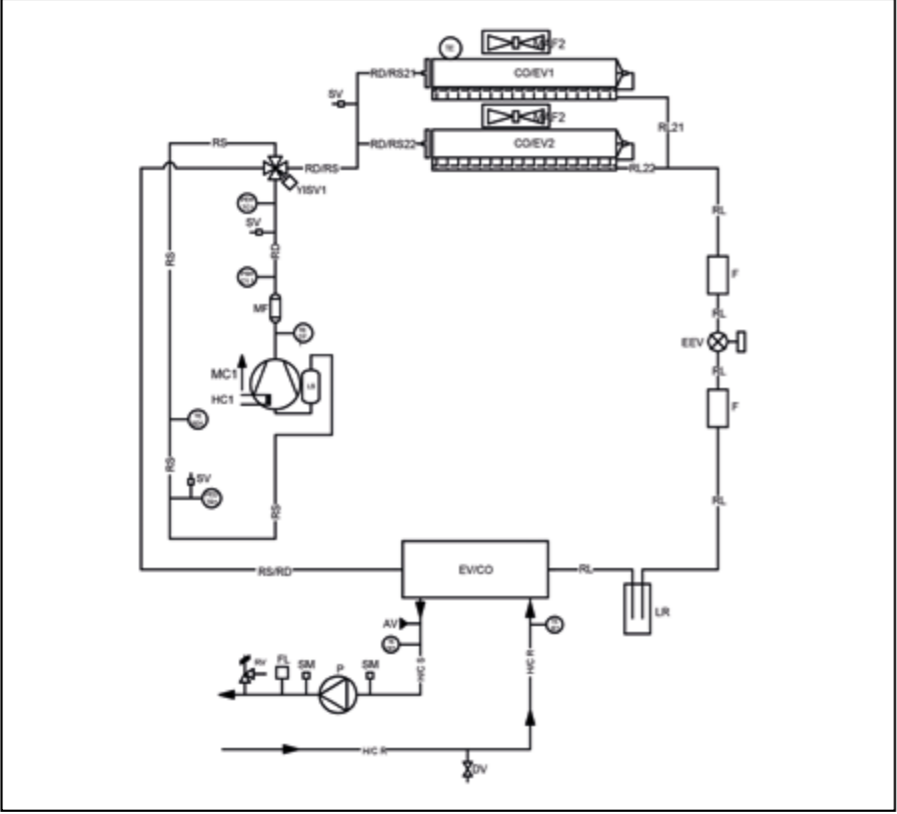

FUNCTIONAL DIAGRAM KEY

Code	Description	RS/RD	Suction / Discharge line
MC	Compressor	H/CS	Plant water out - supply
CO/EV	Condenser	H/CR	Plant water in - return
EV/CO	Evaporator	PEH	High pressure transducer
EEV	Electronic expansion valve in heat pump mode	TC	Low pressure transducer
YISV	Inversion valve	TR	Air temperature probe
LR	Liquid receiver	TE SD	Suction temperature probe
F	Filter drier	TE DT	Discharge temperature probe
SV	Service valve	PSH C	High pressure switch - manual reset
HC	Crankcase heater	TE IE	Temperature probe in - plant return
MAF	Axial fan	TE OE	Temperature probe out - plant delivery
MF	Muffler	DV	Drain valve
LS	Suction separator	RV	Safety valve
RS	Suction line	FL	Flow switch
RD	Discharge line	P	Water pump
RL	Liquid line	AV	Air vent valve
RD/RS	Discharge / Suction line	SM	Service sleeve

A: Heat pump - one buffer tank & one central heating circuit (constant temperature)
 Suitable for heat pumps using R32 & R290 refrigerant

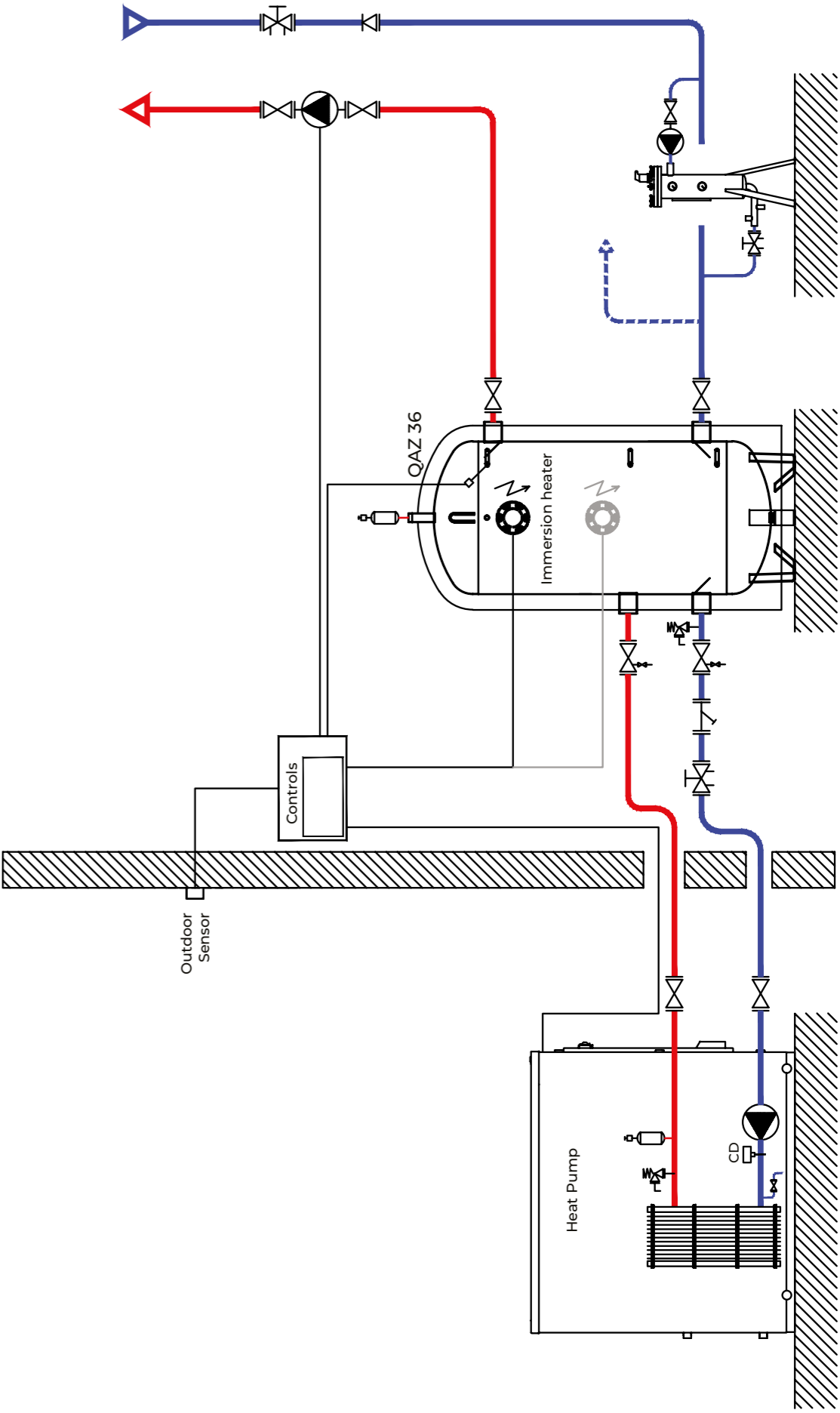

B: Heat pump - one buffer tank & one central heating circuit (constant temperature), managed by LPB bus or 0-10V signal
 Suitable for heat pumps using R32 & R290 refrigerant

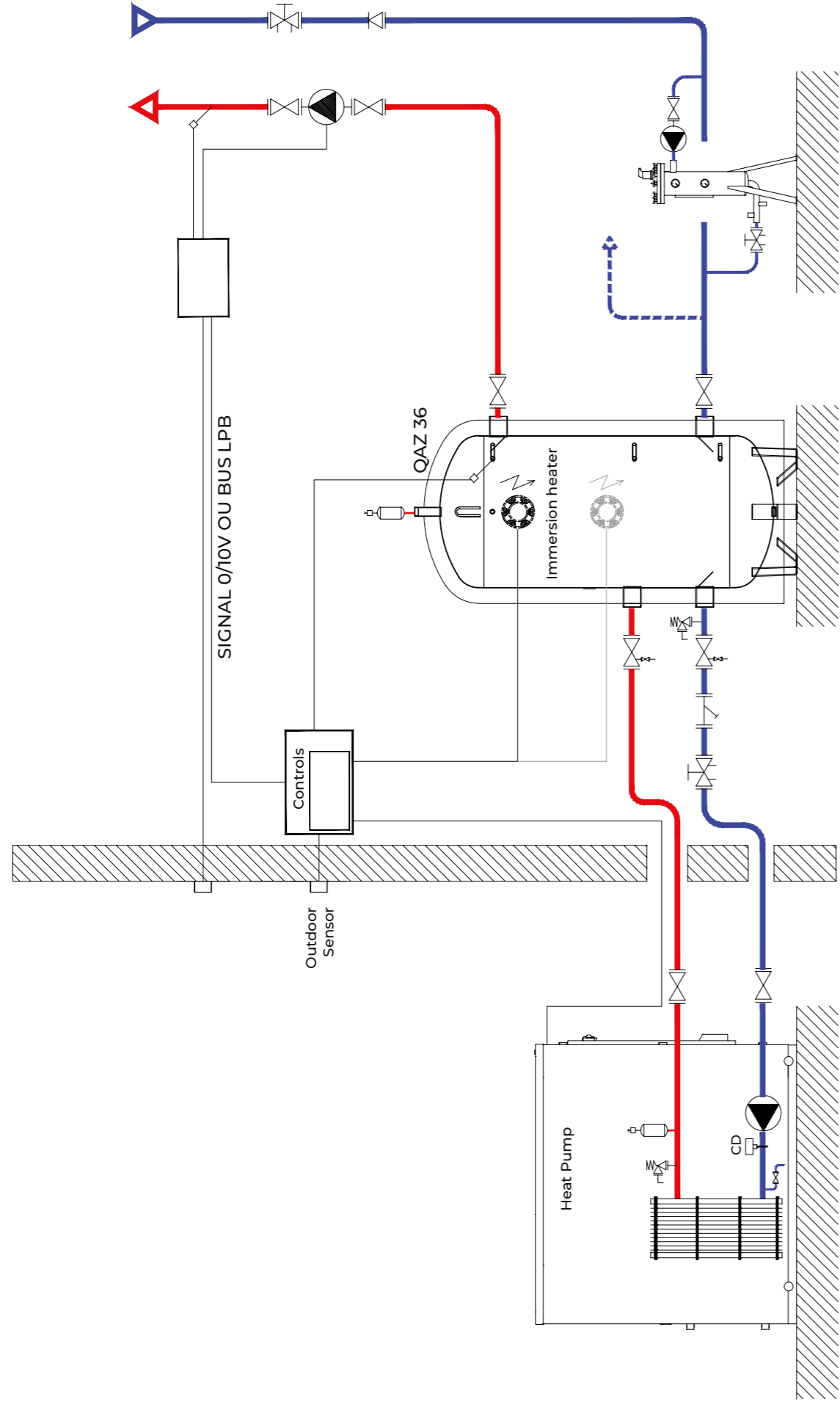

C: Heat pump - one buffer tank & up to 3 central heating circuits with mixer valve & circuit sensor (variable temperature)
 Suitable for heat pumps using R32 & R290 refrigerant

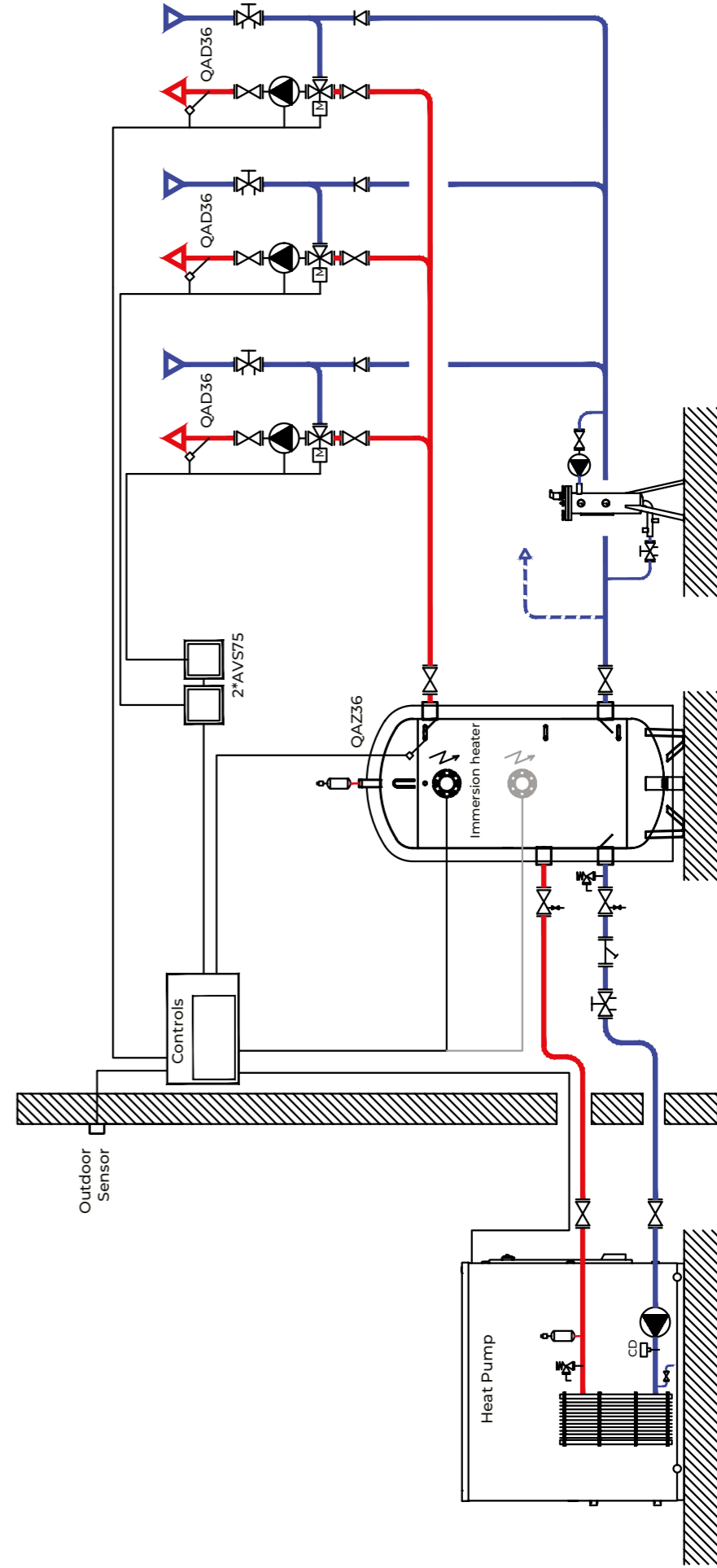

D: Heat pump - cascade one buffer tank & 1 central heating circuit with mixer valve & circuit sensor (regulated temperature)
 Suitable for heat pumps using R32 & R290 refrigerant

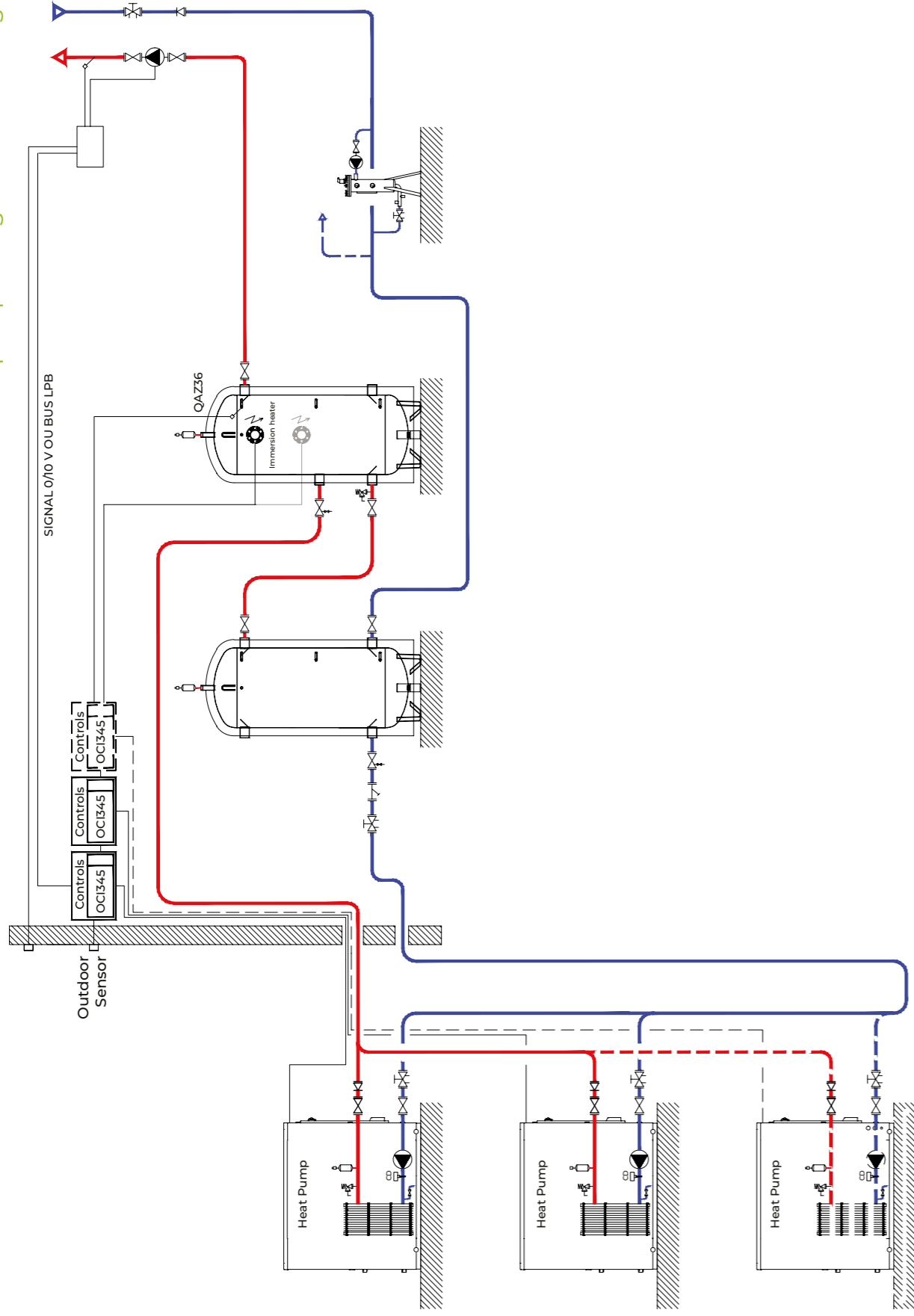

E: Heat Pump - one buffer tank & one central heating circuit with One boiler in Hybrid Set Up
 Suitable for heat pumps using R32 & R290 refrigerant

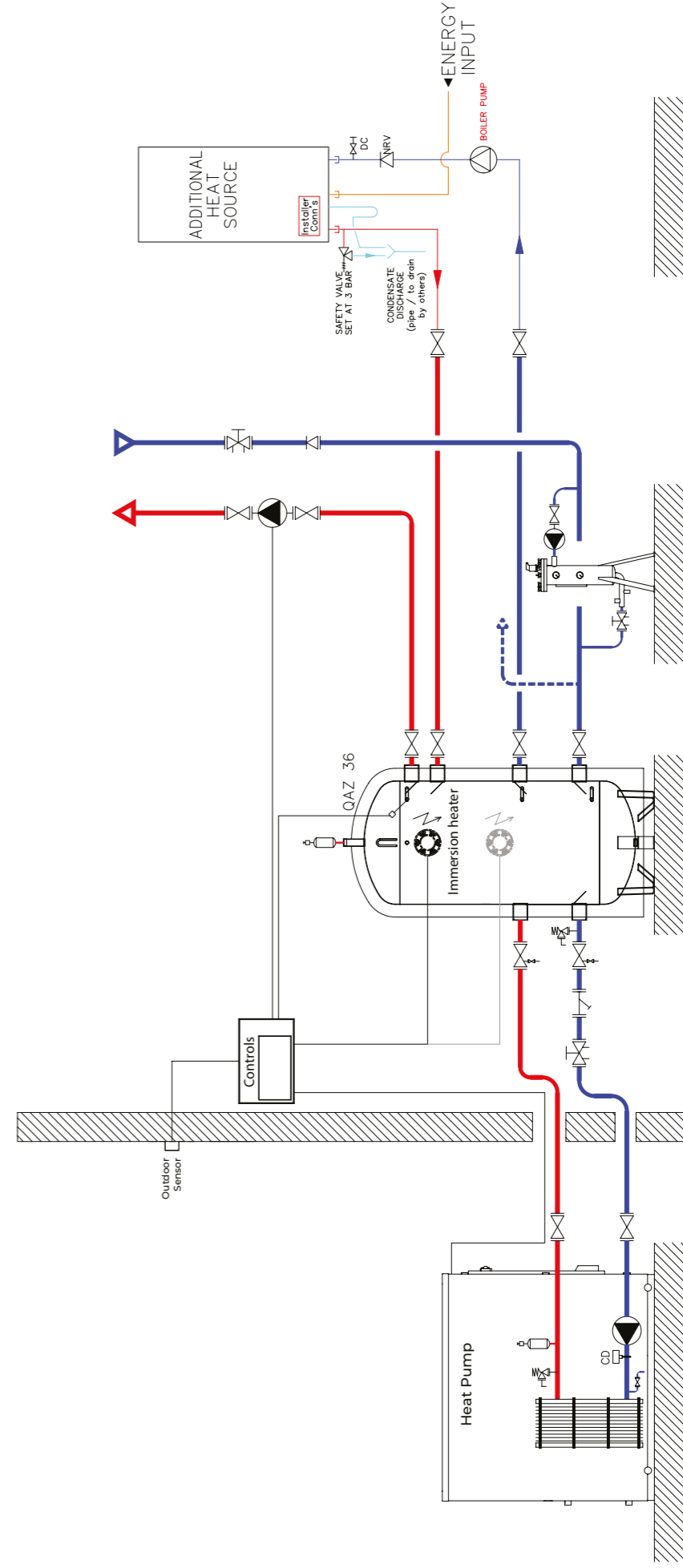

Two unit cascade for heating and DHW with buffer tank for heat pumps using R744 / CO2 refrigerant

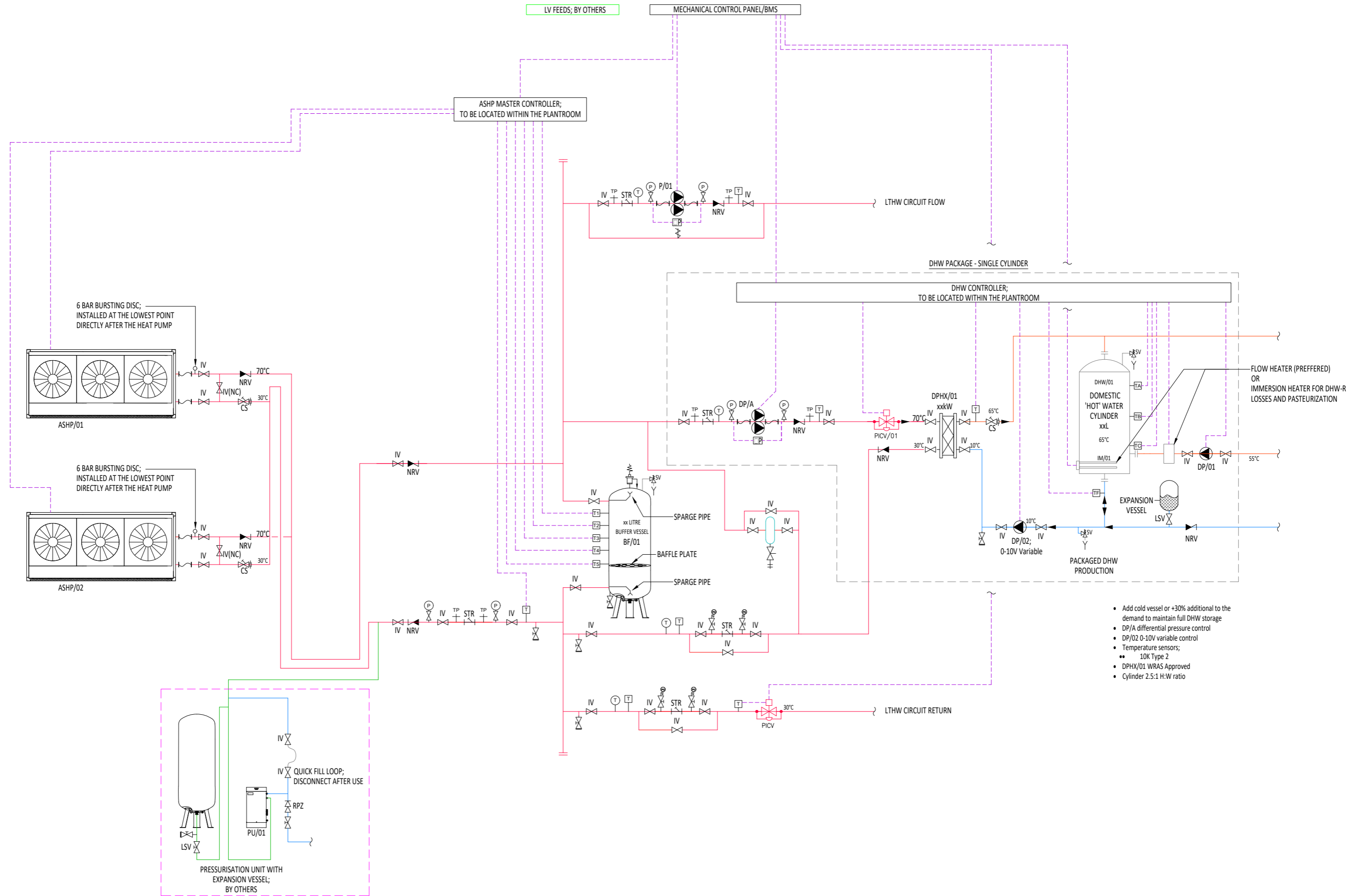

COMBINE

ECOMOD HEAT PUMPS
WITH OUR RANGE OF
COMMERCIAL CONDENSING
BOILERS TO BUILD
THE OPTIMUM
**LOW CARBON HYBRID
HEATING SYSTEM**

Commercial heat pumps ranging from 14kW up to 130kW



COMMERCIAL
CONDENSING
BOILERS

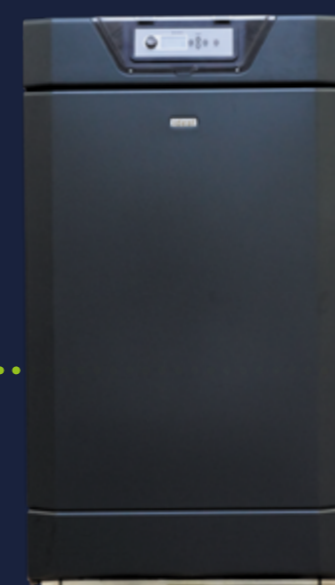

For advice or more information
contact your Ideal Heating Commercial
business development manager
idealcommercialheating.com/contact-us

- EVOMAX 2**
- The UK's number one wall-mounted commercial boiler
 - Wall Hung
 - Aluminium Alloy Heat Exchanger
 - 30 - 150kW
 - 30 - 120kW LPG

- IMAX XTRA 2**
- Floor Standing
 - Aluminium Alloy Heat Exchanger
 - 80 - 280kW
 - Cascade up to 4 boilers for 1120kW output

- IMAX XTRA EL**
- Floor Standing
 - Aluminium Alloy Heat Exchanger
 - 320 - 1240kW
 - Available in 10 models for single or multiple installations

- EVOMOD**
- Floor Standing
 - Stainless Steel Heat Exchanger
 - Modular
 - 250 - 1000kW
 - Up to 1MW output from a single unit, ideal for smaller spaces

- EVOJET**
- Floor Standing
 - Stainless Steel Heat Exchanger
 - 150 - 3000kW
 - Condensing Pressure Jet
 - Natural Gas, LPG, Oil or Dual Fuel

TRAINING AND AFTERSALES SUPPORT

WE ARE COMMITTED TO DELIVERING THE HIGHEST LEVEL OF CUSTOMER SERVICE. WITH MORE THAN 100 YEARS' EXPERIENCE IN THE HEATING INDUSTRY WE ARE TRUSTED BY CUSTOMERS ACROSS THE UK.

DEDICATED SUPPORT AND YEARS OF EXPERIENCE

Ideal Heating lead the way in commercial applications, by ensuring our heating products stay at the forefront of technology, delivering both high efficiency solutions and low running costs, in line with the key market trends and legislation.

At the centre of this trust is the support and unrivalled heating experience provided by our dedicated technical and service engineering team.

The UK contact centre is open 364 days a year, with calls answered directly in person by fully trained members of staff. They can assist with enquiries or help to diagnose and resolve queries over the telephone. Engineer visits are also available for complex projects.

GET SKILLED WITH OUR EXPERTISE?

All Ideal Heating engineers have years of expertise across the full range of heating solutions and are fully trained to the highest possible standards, including all being Gas Safe registered. The only UK Heating manufacturer accredited to deliver in-house F-Gas training and accreditations**, we have been delivering Heat Pump training and qualifications since 2021 and offer the best value courses in the industry at the lowest possible prices. We are registered members of Refcom Elite.

FREE COMMISSIONING AND EXTENDED WARRANTY

Our free commissioning service, by an Ideal Heating commercial engineer is **available on all ECOMOD commercial heat pumps.**

This innovative offer will greatly assist specifiers, merchants and installers, as it not only reduces customer costs it also ensures that the heat pumps are operating correctly and activates the extended warranty.

The **ECOMOD 290HT** and **ECOMOD R32** products. are supplied with a comprehensive 2-year warranty included as standard, increasing to 5 year once commissioned by Ideal Heating.* A 2 year parts only warranty is available on CO2 & CO2Q models.

*2 year warranty extended to 5 years if commissioned by Ideal Heating is only available on ECOMOD 290HT and ECOMOD R32 products. 2 year parts only warranty is available on CO2 & CO2Q models. **As far as we are aware.

INVESTMENT IN STATE-OF-THE-ART TRAINING CENTRES

Ideal Heating commercial customers are further supported with the availability of high-level training. Delivered at state-of-the-art Centres of Excellence, including our flagship training venues at Bridgehead Hull, Leeds and Luton.

The training team also operate from a further 15 locations in the UK, backed-up by our unique mobile roadshow events our full-time expert training managers offer a wide range of comprehensive courses, which can be customised for individual installation and servicing companies.

TRAINING LOCATIONS

Since 2012 we have invested over £10m on providing free or low-cost training to heating installers across the UK and Ireland.

Our training centres are accredited for BPEC and City and Guilds.



SUPPORT



DESIGN AND TECHNICAL SUPPORT

Commercial Technical Help Line:

01482 498376

commercial.services@idealheating.com



SALES SUPPORT

Contact your local sales manager, visit:

[idealcommercialheating.com/contact-us](https://www.idealcommercialheating.com/contact-us)

03330 040 393

E: commercial@idealheating.com



TRAINING

01482 498660

enquiries@expert-academy.co.uk



BIM

BIM objects will be available to download at:

[idealcommercialheating.com/bim](https://www.idealcommercialheating.com/bim)



Commercial products:

Sales, orders, availability, literature and pricing

03330 040 393

Calls cost no more than calls to geographic numbers (01 or 02) and will be included in any inclusive minutes you have with your telephone service provider.

commercial@idealheating.com

Spares:

Sales, orders, availability and pricing

01482 498 665

Technical and customer service:

01482 498 376

commercial.services@idealheating.com